

# PRECIZIKA

METROLOGY



# 1961

# PRESENT

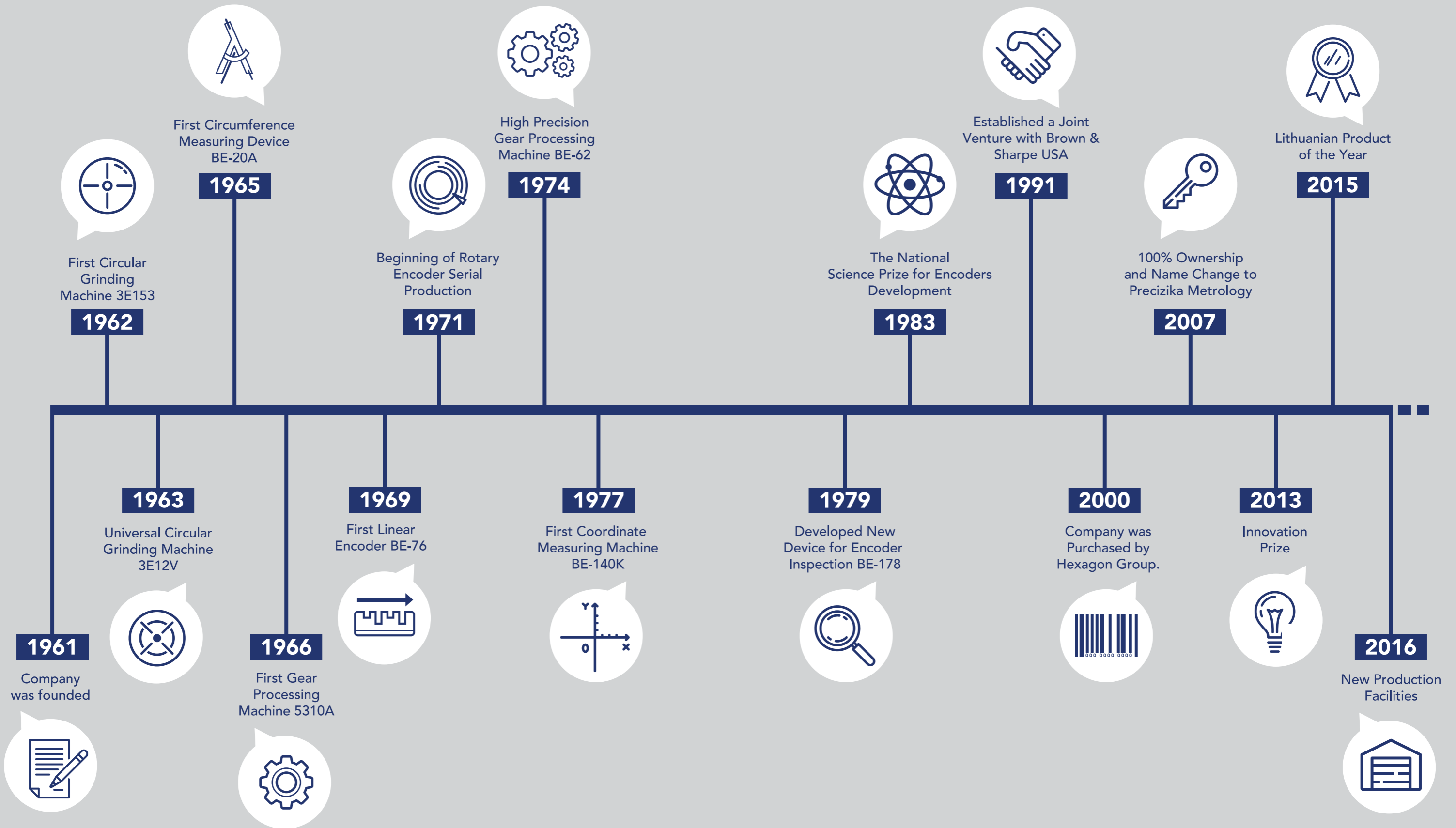

# OUR HISTORY



# ABOUT US

**Precizika Metrology** has a long history of old traditions in the leadership of design and production of metrological equipment – rotary, angle, linear encoders and optical encoder gratings. The Lithuanian company has been in the industry for over 50 years and with this heritage comes both pride and great responsibility to continuously move forward, improve and evolve in order to satisfy the ever-changing industry needs. A huge part of time spent in the industry was dedicated to working with top-of-the-line original equipment manufacturing (OEM) companies, listening to their feedback and providing innovative solutions to a variety of diverse conundrums.

Consistent supply of high quality products and services that match or exceed the quality standards our customers expect and deserve is the main goal that drives us forward, constantly investing in new projects, future proof equipment and bright minds. The ability to take advantage of accumulated know-how and to channel the experience provides us with a unique perspective and position in the market that opens new ways to innovate and provide industry defining product solutions.

## WHAT WE VALUE



**Communication** with potential customers and partners that is sincere, open and honest.



**Timeliness** in providing high quality products and services the customer expects.



**Reliability** and high quality standards of every single manufactured product without any exceptions.



**Passion** for innovating, developing new technological advancements and upgrades.



**Partnerships** that are strong, unwavering, inspired by mutual understanding and goals.

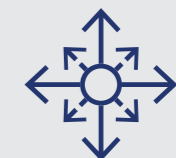

**Flexibility** towards customer demands for adjustments and incremental updates.



# HOW OUR ENCODERS OPERATE

Encoders are used to convert angular or linear displacement into electric signals containing information about the magnitude and direction of movement. After further signal processing by the numeric control devices (processor complexes, digital readout devices), this information is used to control moving parts of the equipment.

Encoders manufactured by **Precizika Metrology** take advantage of photoelectric technology operating on the principle of light modulation or magnetic technology using a combination of permanent magnets and magnetic sensors to detect movement and position.

Absolute encoder is a device that provides true (absolute) positional information, as it generates a unique code for

each position. The resolution is equal to  $2^n$  ( $n$ =number of bit), encoder uses gray or binary coding, which can be translated into different protocols. This encoder type is normally used to monitor object position during power up and power down. Unlike incremental encoders, the encoded output provides the ability to read the object position without moving the encoder. Singleturn absolute encoder delivers a single data item in the form of a "word" in parallel or serial mode for each position of the object, which can be read directly and quickly by control systems, whereas multiturn absolute encoder can perform a greater number of turns and delivers, in addition to the position of the object in the turn, the number of turns performed in relation to a reference mark.

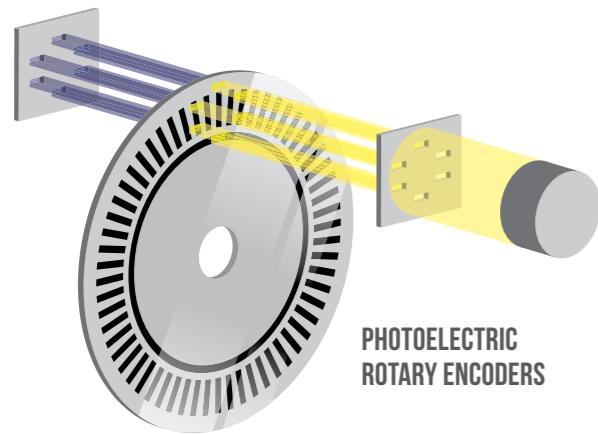

PHOTOELECTRIC ROTARY ENCODERS

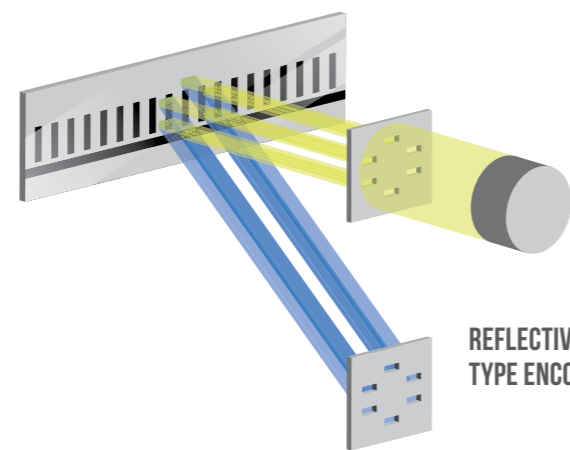

REFLECTIVE TYPE ENCODERS

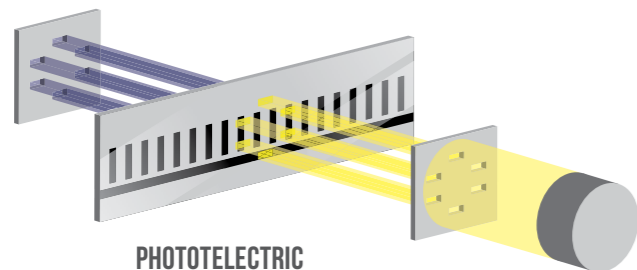

PHOTOELECTRIC LINEAR ENCODERS

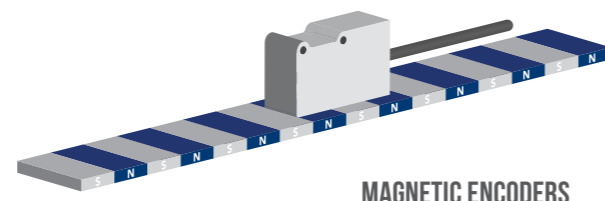

MAGNETIC ENCODERS

## SIGNALS

### SINE-WAVE CURRENT SIGNAL, VERSION A (~ 11 μA); U = +5V±5%

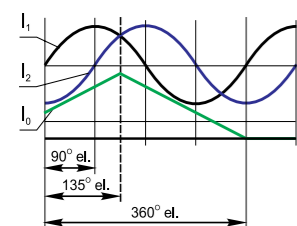

$I_2$  lags  $I_1$  for clockwise rotation (viewed from shaft side)  
 Output signals  $I_1, I_2$  amplitude at load  $1k\Omega$ :  $7...16 \mu A$   
 Value of reference signal  $I_0$  at load  $1k\Omega$ :  $2...8 \mu A$  (useful part)  
 Phase difference between signals  $I_1$  and  $I_2$ :  $90\pm 10^\circ$   
 Phase difference between signals  $I_1$  and  $I_0$ :  $135\pm 60^\circ$

#### RECOMMENDED CONNECTION DIAGRAM

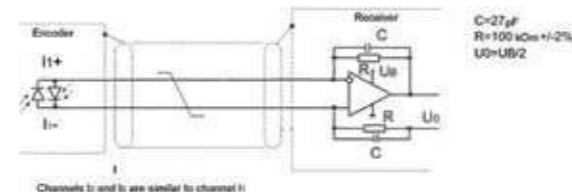

### SINE-WAVE VOLTAGE SIGNAL, VERSION AV (~ 1VPP); U = +5V±5%

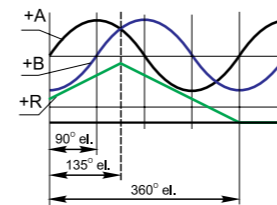

B lags A for clockwise rotation (viewed from shaft side)  
 Output signals A, B amplitude at load  $120\Omega$ :  $0.6...1.2 V$   
 Value of reference signal at load  $120\Omega$ :  $0.2...0.8 V$  (useful part)  
 Phase difference between signals A and B:  $90\pm 10^\circ$   
 Phase difference between signals A and R:  $135\pm 60^\circ$

#### RECOMMENDED CONNECTION DIAGRAM

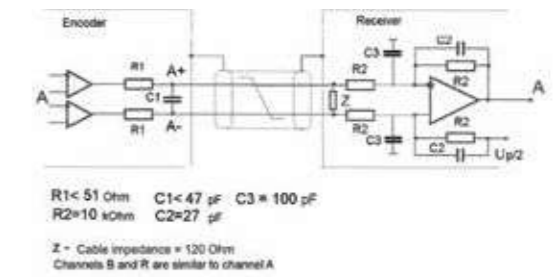

### TTL (□) SQUARE-WAVE SIGNAL, VERSION F; U = +5V±5%

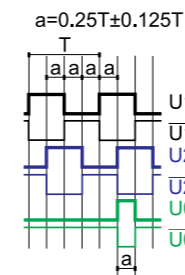

$a = 0.25T \pm 0.125T$   
 $U_2$  lags  $U_1$  for clockwise rotation (viewed from shaft side)  
 Output signals level at current load  $20mA$ :  
 log "1"  $\geq 2.4V$ ; log "0"  $\leq 0.5V$   
 Maximum rise and fall time:  $0.1...0.2 ms$   
 Reference signal delay is no bigger than  $0.1 \mu s$

#### RECOMMENDED CONNECTION DIAGRAM

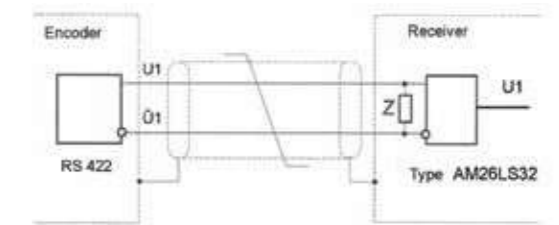

### HTL (□) SQUARE-WAVE SIGNAL, VERSION F; U = +(10...30V)±5%

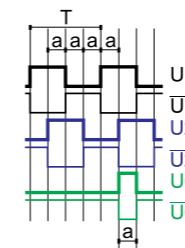

$U_2$  lags  $U_1$  with clockwise rotation (viewed from shaft side)  
 Output signals level at current load  $20 mA$ :  
 log "1"  $\geq (U - 2.0)V$ ; log "0"  $\leq 0.5V$   
 Maximum rise and fall time:  $0.3 ms$   
 Reference signal delay is no bigger than  $0.1 \mu s$

#### RECOMMENDED CONNECTION SCHEME

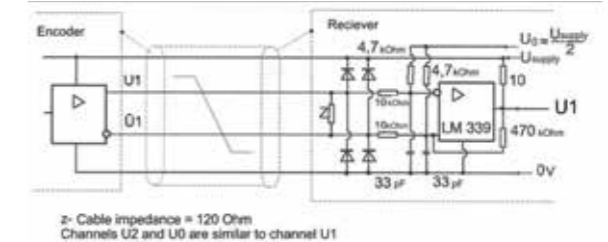

### SSI

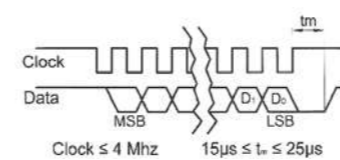

Interface	SSI Binary - Gray
Signals level	EIA RS 485
Clock frequency	160 Hz + 4 MHz
n	Position bit
TTD	3,28 ms + 1,2 ns

### BISS C

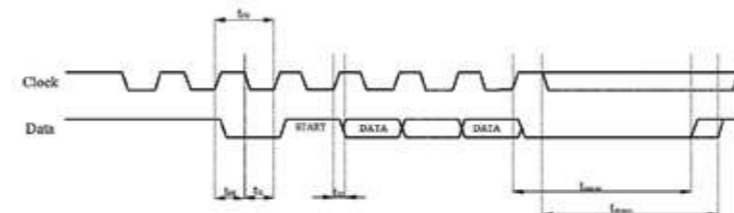

	Min	Max
tCP	100ns	2 x timeout, ns
tSH	50ns	timeout, ns
tSL	50ns	
tSD	10ns	50ns
ttimeout	3,28 ms + 100 ns	

### UVW

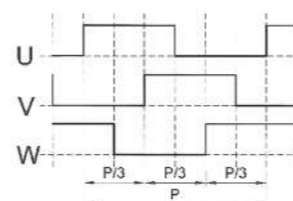





## LINEAR ENCODERS

- |           |           |
|-----------|-----------|
| 70   L18  | 82   L35T |
| 72   L18B | 84   L37  |
| 74   L18T | 86   L50  |
| 76   L23  | 88   MT   |
| 78   LK24 | 94   MK   |
| 80   L35  |           |

03

## ACCESSORIES

- |               |                                     |
|---------------|-------------------------------------|
| 98   SC       | 104   Encoder electrical connection |
| 100   NK      | 107   Cable lengths                 |
| 102   CS 3000 |                                     |
| 103   CS 5500 |                                     |

04

01

## ROTARY ENCODERS

- |               |              |
|---------------|--------------|
| 12   A24HME1  | 30   A58     |
| 14   A28      | 34   AK58    |
| 16   A36      | 40   AK58HE1 |
| 18   A36HME1  | 42   AP58    |
| 20   AK36     | 44   A58HE   |
| 22   AK36HME1 | 46   A58HME  |
| 24   A42M     | 48   A58HE1  |
| 26   A75M     | 50   A102H   |
| 28   AK50     | 52   AM      |

02

## ANGLE ENCODERS

- |            |            |
|------------|------------|
| 56   A90H  | 62   A170  |
| 58   A110  | 64   A170H |
| 60   A110H | 66   A200H |



# ROTARY ENCODERS



MODEL	CROSS SECTION	NUMBER OF LINES* / RESOLUTION	ACCURACY (ARC. SEC)	SHAFT TYPE	OUTPUT SIGNALS
<b>A24HME1</b>		250	± 260	Hollow shaft	~ 1 Vpp TTL, HTL
<b>A28</b>		60 – 2.500	± 0.1T	Solid shaft	TTL
<b>A36</b> (including HME1)		100 – 3.600	± 0.1T	Solid / hollow shaft	~ 11 uApp ~ 1 Vpp TTL, HTL
<b>AK36</b> (including HME1)		Up to 21 bit singleturn ----- Up to 40 bit multiturn	± 30	Solid /hollow shaft	SSI BISS C
<b>A42M</b>		1.000; 2.500	± 0.1T	Hollow shaft	~ 11 uApp ~ 1 Vpp TTL
<b>A75M</b>		512; 2.048; 5.000	± 0.1T	Hollow shaft	~ 1 Vpp TTL

MODEL	CROSS SECTION	NUMBER OF LINES* / RESOLUTION	ACCURACY (ARC. SEC)	SHAFT TYPE	OUTPUT SIGNALS
<b>AK50</b>		Up to 8 bit	± 120	Solid shaft	TTL, HTL
<b>A58</b> (including HE, HME, HE1)		100 – 10.800	± 0.1T	Solid/hollow/ blind shaft**	~ 11 uApp ~ 1 Vpp TTL, HTL
<b>AK58</b> (including HME1)		Up to 21 bit singleturn ----- Up to 40 bit multiturn	± 30	Solid / hollow shaft	SSI BISS C
<b>AP58</b>		1 – 65.536 (pulses per revolution)	± 60	Solid / hollow shaft	TTL, HTL
<b>A102H</b>		5.000; 9.000	± 0.05T	Hollow shaft	~ 11 uApp ~ 1 Vpp TTL
<b>AM</b>		16 – 1.024 for HTL / Up to 12 bit for SSI	± 1.080	Solid shaft	TTL, HTL

\*others only on request. Possible interpolation factor up to x10. \*\*depending on the model



PHOTOELECTRIC ROTARY ENCODER

# A24HME1



Small size



Hollow shaft



Analog output signals



Photoelectric rotary encoder A24HME1 is the smallest diameter encoder in our product range. It can have a Ø2-6mm hollow shaft

depending on customer requirements and produces up to 250.000 output pulses per shaft revolution.

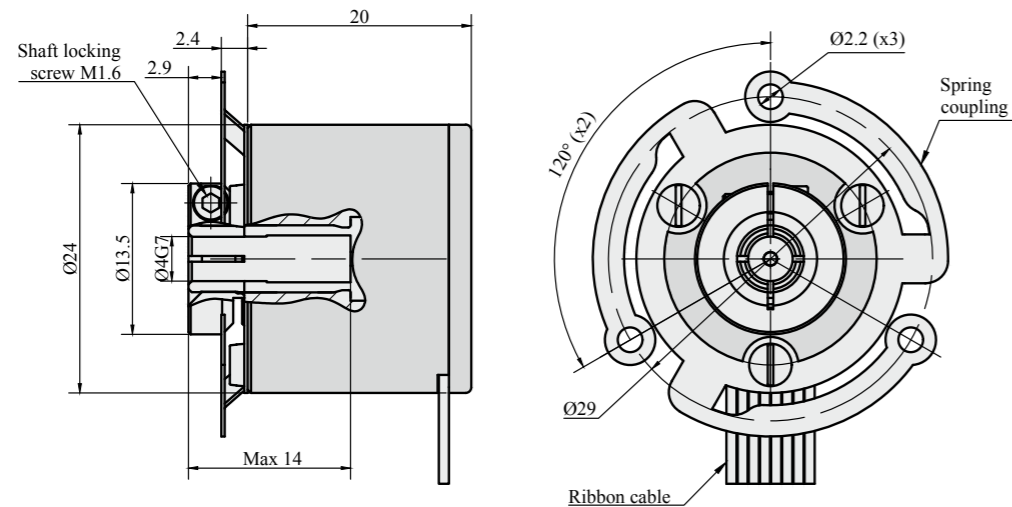

## MOUNTING REQUIREMENTS

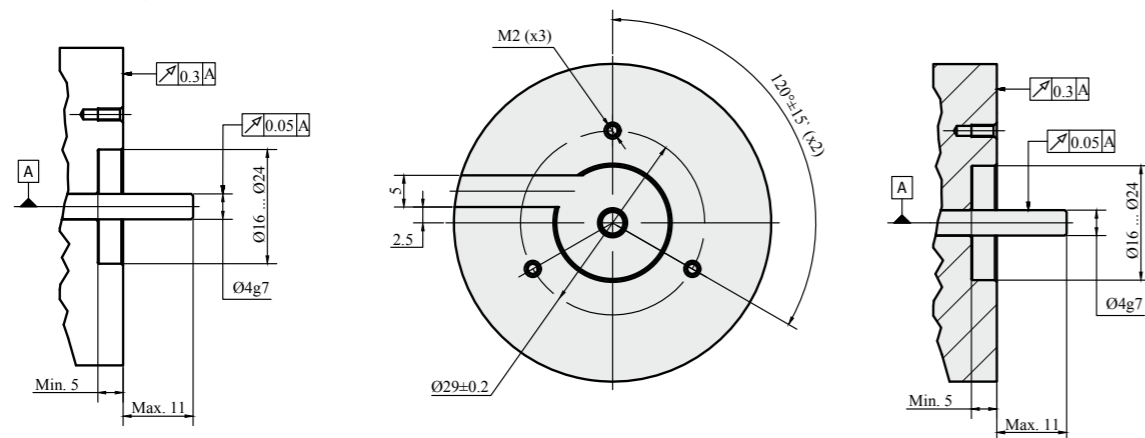

## MECHANICAL DATA

Line number on disc (z)	250	Starting torque at 20°C	≤ 0.005 Nm
Pulse number per shaft revolution	250, 500, 1000, 1250, 2500, 5000, 6250, 10000, 12500, 25000, 31250, 50000, 62500, 125000, 250000	Rotor moment of inertia	< 1 gcm <sup>2</sup>
Maximum shaft speed	10000 rpm	Protection (IEC 529)	IP54
Maximum shaft load: - axial - radial (at shaft end)	5N 10N	Maximum weight without cable	0.04 kg
Accuracy (T <sub>1</sub> -period of lines on disc in arc. sec)	±260 arc. sec	Operating temperature	-40...+85°C
		Storage temperature	-40...+85°C
		Maximum humidity (non-condensing)	98 %
		Permissible vibration (55 to 2000 Hz)	≤ 100 m/s <sup>2</sup>
		Permissible shock (11 ms)	≤ 300 m/s <sup>2</sup>

## ELECTRICAL DATA

VERSION	A24HME1-AV ~ 1 Vpp	A24HME1-F □ TTL; □ HTL
Supply voltage	+5 V ± 5%	+5 V ± 5%; +(10 to 30) V
Max. supply current (without load)	120 mA	120 mA
Light source	LED	LED
Incremental signals	Differential sine +A/-A and +B/-B Amplitude at 120 Ω load: - A = 0.6-1.2 V - B = 0.6-1.2 V	Differential square-wave U1/Ū1 and U2/Ū2. Signal levels at 20 mA load current: - low (logic "0") ≤ 0.5 V at U <sub>p</sub> =+5 V - low (logic "0") ≤ 1.5 V at U <sub>p</sub> =10 to 30 V - high (logic "1") ≥ 2.4 V at U <sub>p</sub> =+5 V - high (logic "1") ≥ (U <sub>p</sub> -2) V at U <sub>p</sub> =10 to 30 V
Reference signal	One quasi-triangular +R and its complementary -R per revolution. Signals magnitude at 120Ω load - R = 0.2-0.8 V (usable component)	One differential square-wave U0/Ū0 per revolution. Signal levels at 20 mA load current: - low (logic "0") < 0.5 V at U <sub>p</sub> =+5 V - low (logic "0") < 1.5 V at U <sub>p</sub> =10 to 30 V - high (logic "1") > 2.4 V at U <sub>p</sub> =+5 V - high (logic "1") > (U <sub>p</sub> -2) V at U <sub>p</sub> =10 to 30 V
Maximum operating frequency	(-3 dB) ≥ 180 kHz	(160 x k) kHz, k-interpolation factor
Direction of signals	+B lags +A for clockwise rotation (viewed from shaft side)	U2 lags U1 with clockwise rotation (viewed from shaft side)
Maximum rise and fall time	-	< 0.5 μs
Standard cable length	1 m, without connector	1 m, without connector
Maximum cable length	25 m	25 m

Output signals

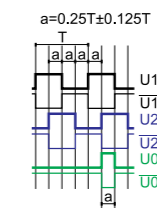
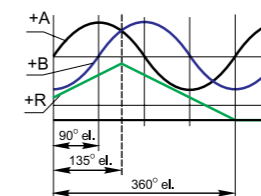

Note:

- Maximum working rotation speed (with proper encoder counting) is limited by maximum operating frequency and maximum mechanical rotation speed.
- If cable extension is used, power supply conductor cross-section should not be smaller than 0.5 mm<sup>2</sup>

## ACCESSORIES

### CONNECTORS FOR CABLE

C12  
12-pin round connector

D9  
9-pin flat connector

## ORDER FORM

A24HME1 - X1 - X2 - X3 - X4 - X5/X6

Output signal Version (X1):	Pulse number Per revolution (X2):	Hollow shaft diameter (X3):	Supply Voltage (X4):	Cable length (X5):	Connector type (X6):
<b>AV</b>	<b>250</b>	<b>2</b> - Ø 2 mm	<b>05V</b> - +5V	<b>0,5</b> - 0,5 m	<b>W</b> - without connector
<b>F</b>	<b>250000*</b>	<b>3</b> - Ø 3 mm	<b>30V</b> - 10 to 30V*	<b>01</b> - 1 m	<b>C12</b> - round, 12 pins
		<b>4</b> - Ø 4 mm		<b>02</b> - 2 m	<b>D9</b> - flat, 9 pins
		<b>5</b> - Ø 5 mm			
		<b>6</b> - Ø 6 mm			

ORDER EXAMPLES: 1) A24HME1-F-2500-05V-01/W  
2) A24HME1-F-10000-30V-02/C12

PHOTOELECTRIC ROTARY ENCODER

# A28



Small size



Photoelectric rotary encoder **A28** is a small 28mm diameter incremental encoder that can have up to 25.000 output pulses per revolution.

Small size is its primary feature that enables the customer to fit it in tight places without any hassle.

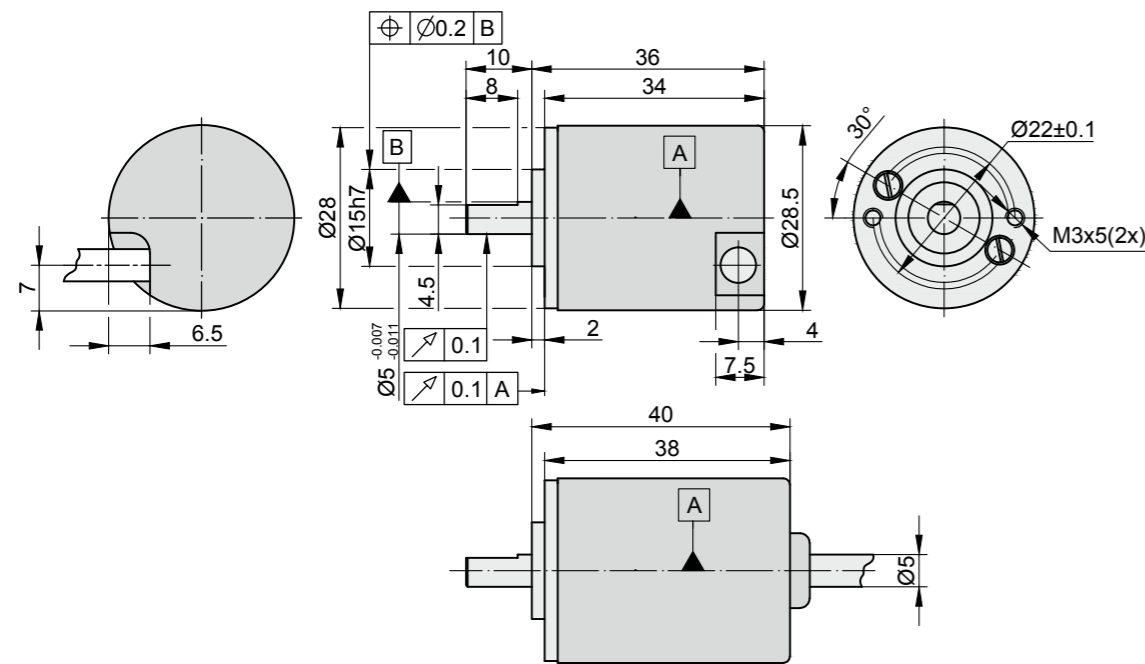

## MECHANICAL DATA

Line number on disc (z)	60; 100; 200; 250; 360; 500; 1000; 1024; 1500; 2000; 2500	Protection (IEC 529) - for axial cable outlet - for radial cable outlet	IP54 IP64
Number of output pulses per revolution	Z x k, where k=1,2,3,4,5,8,10	Maximum weight without cable	0.045 kg
Maximum shaft speed	6000 rpm	Operating temperature	-10...+70 °C
Maximum shaft load: - axial - radial (at shaft end)	5N 10N	Storage temperature	-30...+80 °C
Accuracy (T <sub>1</sub> -period of lines on disc in arc. sec)	±0.1T <sub>1</sub> arc. sec	Maximum humidity (non-condensing)	98 %
Starting torque at 20°C	≤ 0.015 Nm	Permissible vibration (55 to 2000 Hz)	≤ 100 m/s <sup>2</sup>
Rotor moment of inertia	< 2 gcm <sup>2</sup>	Permissible shock (11 ms)	≤ 300 m/s <sup>2</sup>

## ELECTRICAL DATA

VERSION	A28-F □ □ TTL
Supply voltage	+5 V ± 5%
Max. supply current (without load)	120 mA
Light source	LED
Incremental signals	Differential square - wave U1/U1 and U2/U2. Signal levels at 20 mA load current: - low (logic "0") ≤ 0.5 V - high (logic "1") ≥ 2.4 V
Reference signal	One differential square-wave U0/U0 per revolution. Signal levels at 20 mA load current : - low (logic "0") ≤ 0.5 V - high (logic "1") ≥ 2.4 V

Maximum operating frequency	(160 x k) kHz, k-interpolation factor
Direction of signals	U2 lags U1 for clockwise rotation (viewed from shaft side)
Maximum rise and fall time	< 0.5 μs
Standard cable length	0.5 m; without connector
Maximum cable length	25 m

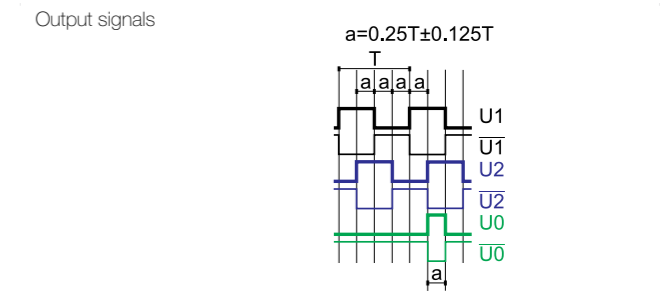

## ACCESSORIES

CONNECTORS FOR CABLE	B12 12-pin round connector	C12 12-pin round connector	D9 9-pin flat connector	D15 15-pin flat connector	RS10 10-pin round connector	ONC 10-pin round connector
DIGITAL READOUT DEVICES	CS3000			CS5500		
COUPLING	SC30					

Notes:

- Maximum working rotation speed (with proper encoder counting) is limited by maximum operating frequency and maximum mechanical rotation speed.
- If cable extension is used, power supply conductor cross-section should not be smaller than 0.5 mm<sup>2</sup>

## ORDER FORM

A28 - F - X1/X2 - X3/X4

Pulse number Per revolution (X1):	(Optional) line number on disc (z) (X2):	Cable length and outlet (X3):	Connector type (X4):
60	60	R01 - 1m (R-radial outlet)	W - without connector
25000	2500	R02 - 2m	B12 - round, 12 pins
		A01 - 1m (A-axial outlet)	C12 - round, 12 pins
		A02 - 2m	D9 - flat, 9 pins
			D15 - flat, 15 pins
			R510 - round, 10 pins
			ONC - round, 10 pins

ORDER EXAMPLES: 1) A28-F-2500-R01/W  
2) A28-F-2500/250-R01/W



PHOTOELECTRIC ROTARY ENCODER

# A36



Small size



Analog output signals



Photoelectric rotary encoder A36 is an incremental encoder that is available in digital or analog output signal versions depending on customer preferences. It can have up to 36.000 output pulses per

revolution and, because of its quite small diameter, can be fitted in narrow areas.

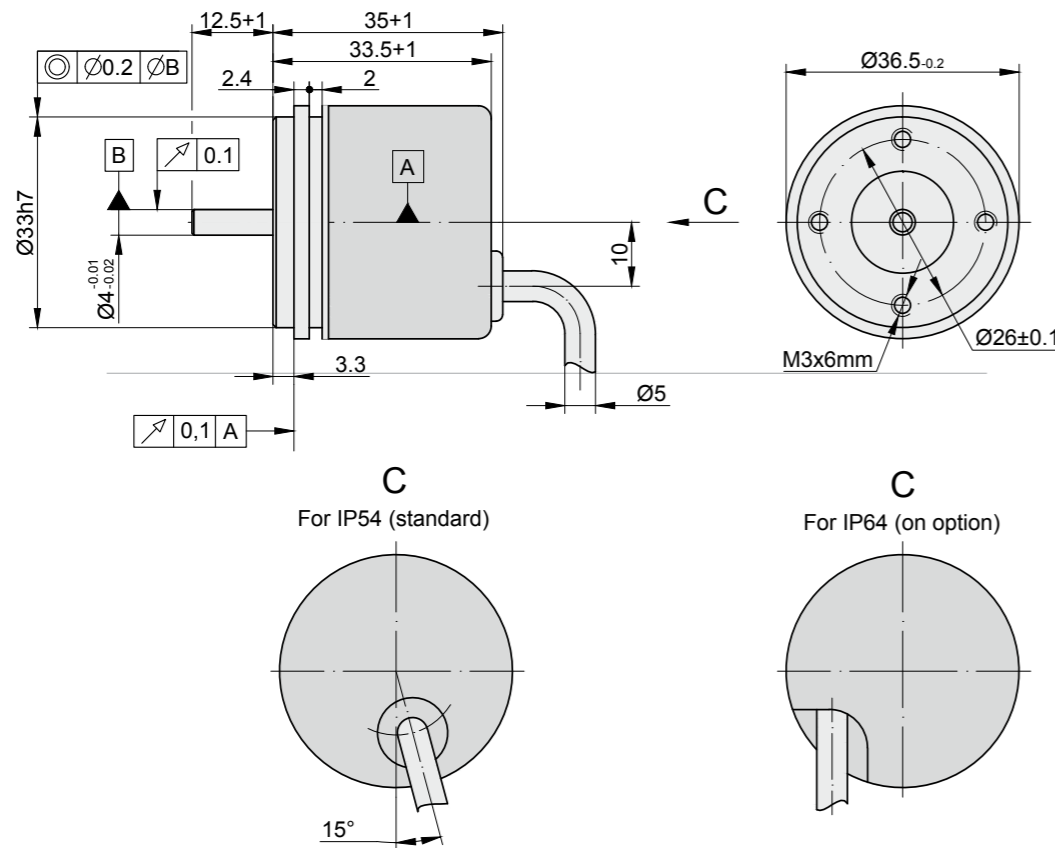

## MECHANICAL DATA

Line number on disc (z)	100; 200; 250; 360; 500; 1000; 1024; 1500; 2000; 2500; 3600	Rotor moment of inertia	< 2 gcm <sup>2</sup>
Number of output pulses per revolution	Z x k, where k=1,2,3,4,5,8,10	Protection (IEC 529) - for axial cable outlet - for radial cable outlet	IP54 IP64
Maximum shaft speed	10000 rpm	Maximum weight without cable	0.07 kg
Maximum shaft load: - axial - radial (at shaft end)	5N 10N	Operating temperature	-10...+70 °C
Accuracy (T <sub>1</sub> -period of lines on disc in arc. sec)	±0.1T <sub>1</sub> arc. sec	Storage temperature	-30...+80 °C
Starting torque at 20°C	≤ 0.002 Nm	Maximum humidity (non-condensing)	98 %
		Permissible vibration (55 to 2000 Hz)	≤ 100 m/s <sup>2</sup>
		Permissible shock (11 ms)	≤ 300 m/s <sup>2</sup>

## ELECTRICAL DATA

VERSION	A36-A ~ 11 µApp	A36-AV ~ 1 Vpp	A36-F TTL; HTL
Supply voltage	+5 V ± 5%	+5 V ± 5%	+5 V ± 5%; +(10 to 30) V
Max. supply current (without load)	80 mA	120 mA	120 mA
Light source	LED	LED	LED
Incremental signals	Two sinusoidal I <sub>1</sub> and I <sub>2</sub> Amplitude at 1 kΩ load: - I <sub>1</sub> = 7-16 µA - I <sub>2</sub> = 7-16 µA	Differential sine +A/-A and +B/-B Amplitude at 120 Ω load: - A = 0.6-1.2 V - B = 0.6-1.2 V	Differential square-wave U1/U1̄ and U2/U2̄. Signal levels at 20 mA load current: - low (logic "0") ≤ 0.5 V at U <sub>p</sub> =+5 V - low (logic "0") ≤ 1.5 V at U <sub>p</sub> =10 to 30 V - high (logic "1") ≥ 2.4 V at U <sub>p</sub> =+5 V - high (logic "1") ≥ (U <sub>p</sub> -2) V at U <sub>p</sub> =10 to 30 V
Reference signal	One quasi-triangular I <sub>0</sub> peak per revolution. Signal magnitude at 1 kW load: - I <sub>0</sub> = 2-8 µA (usable component)	One quasi-triangular +R and its complementary -R per revolution. Signals magnitude at 120Ω load - R = 0.2-0.8 V (usable component)	One differential square-wave U0/U0̄ per revolution. Signal levels at 20 mA load current: - low (logic "0") < 0.5 V at U <sub>p</sub> =+5 V - low (logic "0") < 1.5 V at U <sub>p</sub> =10 to 30 V - high (logic "1") > 2.4 V at U <sub>p</sub> =+5 V - high (logic "1") > (U <sub>p</sub> -2) V at U <sub>p</sub> =10 to 30 V
Maximum operating frequency	(-3 dB) ≥ 160 kHz	(-3 dB) ≥ 160 kHz	(160 x k) kHz, k-interpolation factor
Direction of signals	I <sub>2</sub> lags I <sub>1</sub> for clockwise rotation (viewed from shaft side)	+B lags +A for clockwise rotation (viewed from shaft side)	U2 lags U1 with clockwise rotation (viewed from shaft side)
Maximum rise and fall time	-	-	< 0.5 µs
Standard cable length	1 m, without connector	1 m, without connector	1 m, without connector
Maximum cable length	5 m	25 m	25 m

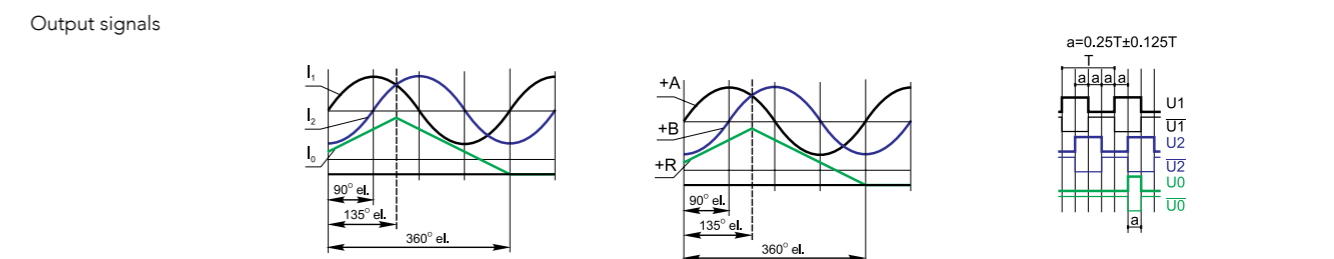

Note:  
1. Maximum working rotation speed (with proper encoder counting) is limited by maximum operating frequency and maximum mechanical rotation speed.  
2. If cable extension is used, power supply conductor cross-section should not be smaller than 0.5 mm<sup>2</sup>

## ACCESSORIES

CONNECTORS FOR CABLE	B12 12-pin round connector	C9 12-pin round connector	C12 12-pin round connector	D9 9-pin flat connector	D15 15-pin flat connector	RS10 10-pin round connector	ONC 10-pin round connector
DIGITAL READOUT DEVICES	CS3000			CS5500			
COUPLING				SC30			
EXTERNAL INTERPOLATOR				NK			

## ORDER FORM

<b>A36</b>	-	<b>X1</b>	-	<b>X2/X3</b>	-	<b>X4</b>	-	<b>X5/X6</b>
Output signal Version (X1):	Pulse number Per revolution (X2):	(Optional) line Number on disc (z) (X3):	Supply Voltage (X4):	Cable length and outlet (X5):	Connector type (X6):			
<b>A</b> <b>AV</b> <b>F</b>	<b>100</b> ... <b>36000*</b>	<b>100</b> ... <b>3600</b>	<b>05V</b> - +5V <b>30V</b> - 10 to 30V*	<b>A01</b> - 1m (A-axial) <b>A02</b> - 2m ... <b>R01</b> - 1m (R-radial) <b>R02</b> - 2m ...	<b>W</b> - without connector <b>B12</b> - round, 12 pins <b>C9</b> - round, 9 pins <b>C12</b> - round, 12 pins <b>D9</b> - flat, 9 pins <b>D15</b> - flat, 15 pins <b>RS10</b> - round, 10 pins <b>ONC</b> - round, 10 pins			
*only F signal version for >3600 pulses		*only for A36-F		*only for A36-F with HTL output signals				
ORDER EXAMPLES: 1) A36-F-2500-05V-A01/W-0 2) A36-F-36000/3600-05V-A02/C12								

PHOTOELECTRIC ROTARY ENCODER

# A36HME1



Small size



Hollow Shaft



Analog output signals



A36HME1 is a photoelectric rotary encoder that produces up to 36.000 output pulses per revolution. It has a blind hollow shaft and is available

in three signal options: 11 uApp, 1 Vpp and TTL or HTL.

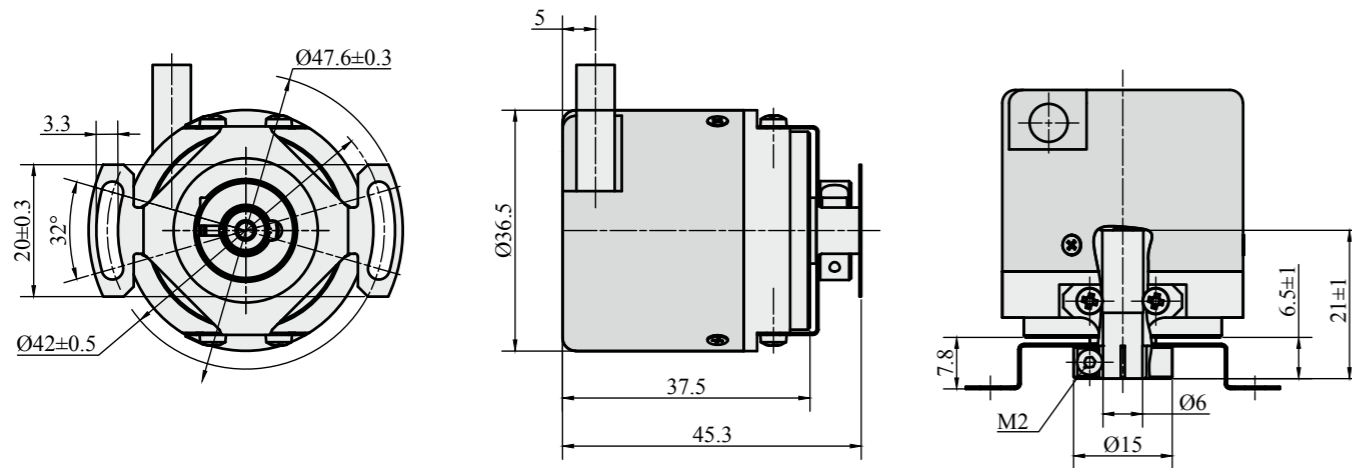

## MOUNTING REQUIREMENTS

## MOUNTING ACCESSORIES (PLATES)

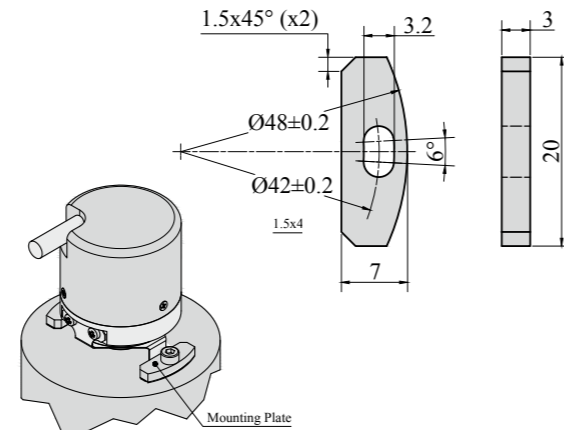
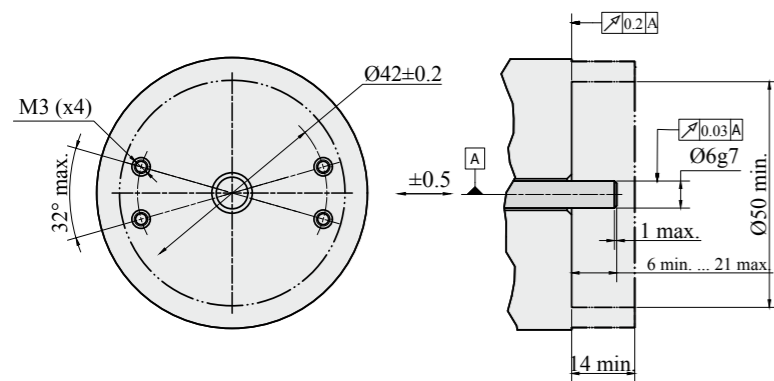

## MECHANICAL DATA

Line number on disc (z)	100, 200, 250, 360 500, 1000, 1024, 1500 2000, 2500, 3600	Rotor moment of inertia	< 2 gcm <sup>2</sup>
Pulse number per shaft revolution	Z x k, where k=1, 2, 3, 4, 5, 8, 10	Protection (IEC 529)	IP64
Maximum shaft speed	10000 rpm	Maximum weight without cable	0.07 kg
Permissible motion of shaft:		Operating temperature	-10...+70°C
- axial	$\pm 0.5 \text{ mm}$	Storage temperature	-30...+80°C
- radial (at shaft end)	$\pm 0.03 \text{ mm}$	Maximum humidity (non-condensing)	98 %
Accuracy (T <sub>1</sub> -period of lines on disc)	$\pm 0.1T \text{ arc. sec}$	Permissible vibration (55 to 2000 Hz)	$\leq 100 \text{ m/s}^2$
Starting torque at 20°C	$\leq 0.002 \text{ Nm}$	Permissible shock (11 ms)	$\leq 300 \text{ m/s}^2$

## ELECTRICAL DATA

VERSION	A36HME1-A $\sim 11 \mu\text{App}$	A36HME1-AV $\sim 1 \text{ Vpp}$	A36HME1-F $\square$ TTL; $\square$ HTL
Supply voltage	+5 V $\pm 5\%$	+5 V $\pm 5\%$	+5 V $\pm 5\%$ ; +(10 to 30) V
Max. supply current (without load)	80 mA	120 mA	120 mA
Light source	LED	LED	LED
Incremental signals	Two sinusoidal I <sub>1</sub> and I <sub>2</sub> Amplitude at 1 k $\Omega$ load: - I <sub>1</sub> = 7-16 $\mu\text{A}$ - I <sub>2</sub> = 7-16 $\mu\text{A}$	Differential sine +A/-A and +B/-B Amplitude at 120 $\Omega$ load: - A = 0.6-1.2 V - B = 0.6-1.2 V	Differential square-wave U1/U $\bar{1}$ and U2/U $\bar{2}$ . Signal levels at 20 mA load current: - low (logic "0") $\leq 0.5 \text{ V}$ at U <sub>p</sub> =+5 V - low (logic "0") $\leq 1.5 \text{ V}$ at U <sub>p</sub> =10 to 30 V - high (logic "1") $\geq 2.4 \text{ V}$ at U <sub>p</sub> =+5 V - high (logic "1") $\geq (U_p - 2) \text{ V}$ at U <sub>p</sub> =10 to 30 V
Reference signal	One quasi-triangular I <sub>0</sub> peak per revolution. Signal magnitude at 1 k $\Omega$ load: - I <sub>0</sub> = 2-8 $\mu\text{A}$ (usable component)	One quasi-triangular +R and its complementary -R per revolution. Signals magnitude at 120 $\Omega$ load - R = 0.2-0.8 V (usable component)	One differential square-wave U0/U $\bar{0}$ per revolution. Signal levels at 20 mA load current: - low (logic "0") < 0.5 V at U <sub>p</sub> =+5 V - low (logic "0") < 1.5 V at U <sub>p</sub> =10 to 30 V - high (logic "1") > 2.4 V at U <sub>p</sub> =+5 V - high (logic "1") > (U <sub>p</sub> -2) V at U <sub>p</sub> =10 to 30 V
Maximum operating frequency	(-3 dB) $\geq 160 \text{ kHz}$	(-3 dB) $\geq 160 \text{ kHz}$	(160 x k) kHz, k-interpolation factor
Direction of signals	I <sub>2</sub> lags I <sub>1</sub> for clockwise rotation (viewed from shaft side)	+B lags +A for clockwise rotation (viewed from shaft side)	U2 lags U1 with clockwise rotation (viewed from shaft side)
Maximum rise and fall time	-	-	< 0.5 $\mu\text{s}$
Standard cable length	1 m, without connector	1 m, without connector	1 m, without connector
Maximum cable length	5 m	25 m	25 m
Output signals			

Note:

- Maximum working rotation speed (with proper encoder counting) is limited by maximum operating frequency and maximum mechanical rotation speed.
- If cable extension is used, power supply conductor cross-section should not be smaller than 0.5 mm<sup>2</sup>

## ACCESSORIES

CONNECTORS FOR CABLE	B12 12-pin round connector	C9 12-pin round connector	C12 12-pin round connector	D9 9-pin flat connector	D15 15-pin flat connector	RS10 10-pin round connector	ONC 10-pin round connector
DIGITAL READOUT DEVICES					CS3000	CS5500	
COUPLING					SC30		
EXTERNAL INTERPOLATOR					NK		

## ORDER FORM

A36HME1 - X1 - X2 - X3 - X4/X5

Output Signal Version (X1):	Pulse number per revolution (X2):	Supply Voltage (X3):	Cable length and outlet (X4):	Connector type (X5):
A AV F	100 ... 36000*	05V - +5V 30V - 10 to 30V*	A01 - 1m (A-axial) A02 - 2m	W - without connector B12 - round, 12 pins C9 - round, 9 pins C12 - round, 12 pins D9 - flat, 9 pins D15 - flat, 15 pins RS10 - round, 10 pins ONC - round, 10 pins
		*only for A36HME1-F with HTL output signals	R01 - 1m (R-radial) R02 - 2m	

ORDER EXAMPLES: 1) A36HME1-A-2500-05V-A01/W  
2) A36HME1-F-36000-30V-A02/C12



PHOTOELECTRIC ROTARY ENCODER

# AK36



Absolute rotary encoder AK36 uses photoelectric technology and is available in singleturn and multiturn versions. Using SSI or BiSS seri-

al interface, it can reach up to 21 bit singleturn and 40 bit multiturn resolutions per revolution.

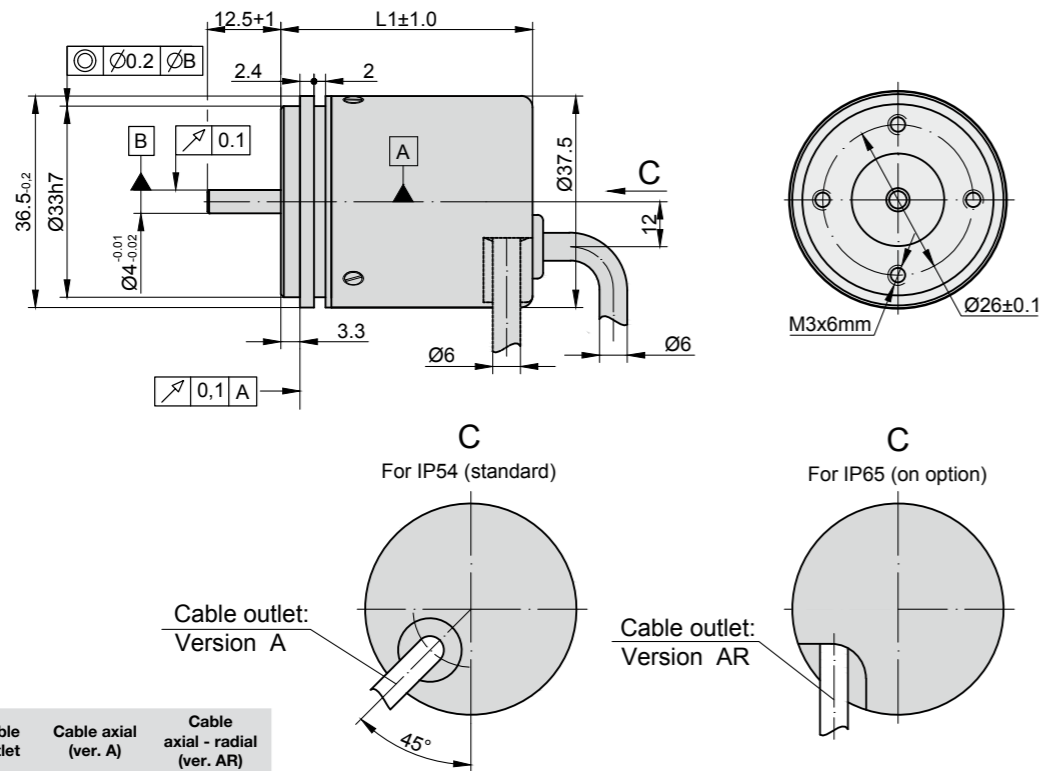

	Cable outlet	Cable axial (ver. A)	Cable axial - radial (ver. AR)
Singleturn	L1	39	39
Multiturn	L1	55	60

## MECHANICAL DATA

Maximum shaft speed	10000 rpm	Operating temperature:	-20...+80 °C
Maximum shaft load:	5N	- singleturn version	-10...+70 °C
- axial	10N	- multiturn version	
- radial (at shaft end)		Storage temperature:	-30...+90 °C
Starting torque at 20°C	≤ 0.002 Nm	- singleturn version	-20...+80 °C
Rotor moment of inertia	< 2 gcm <sup>2</sup>	- multiturn version	
Protection (IEC 529)	IP54	Maximum humidity (non-condensing)	98 %
- Standard	IP64	Permissible vibration (55 to 2000 Hz)	≤ 100 m/s <sup>2</sup>
- Optional		Permissible shock (11 ms)	≤ 300 m/s <sup>2</sup>
Maximum weight without cable	0.1 kg		

## ELECTRICAL DATA

Resolution:	
Singleturn version:	9... 21 bit
- with interface BiSS C	9... 21 bit
- with interface SSI	9... 21 bit
Multiturn version:	9... 21 bit
- single turn resolution with BiSS C	12/16/20/24 bit
- multiturn resolution with BiSS C	9... 21 bit
- single turn resolution with SSI	9... 40 bit
- multiturn resolution with SSI	9... 40 bit
Output code	Gray, binary
Data interface	SSI, BiSS C
Accuracy	± 30 arc sec

Supply voltage	+5V ± 5%
Light source	LED
Maximum operating frequency:	10 MHz
- with interface BiSS C	4 MHz
- with interface SSI	
Cable length (standard)	1 m
Standard cable length	1 m, without connector
Maximum cable length	25 m

### BiSS C serial interface

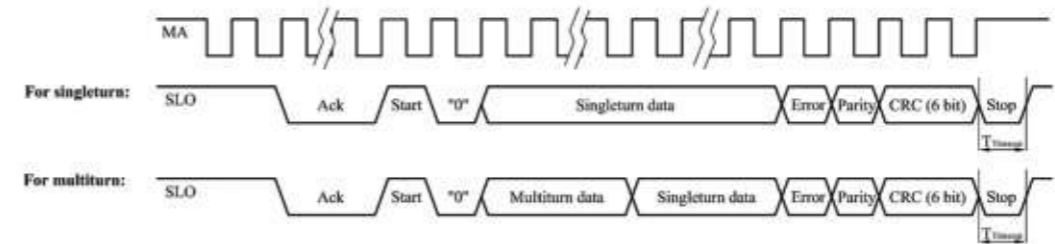

### SSI serial interface

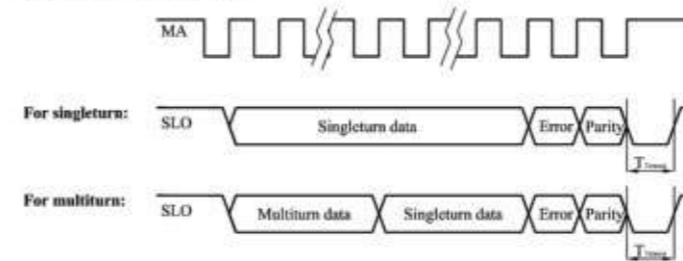

Interface	BiSS C
T <sub>rise</sub>	1.2 µs - 26 µs
Clock frequency	62.5 kHz - 10 MHz

Interface	SSI
T <sub>rise</sub>	1.2 µs - 26 µs
Clock frequency	62.5 kHz - 4 MHz

Note:

- Error and parity bits should be determined during order.

## ACCESSORIES

CONNECTORS FOR CABLE	C9 9-pin round connector	C12 12-pin round connector	D9 9-pin flat connector
COUPLING	SC30		

## ORDER FORM

AK36	X1	X2	X3/X4	X5	X6/X7	
Versions (X1):	Output signals Interface (serial) (X2):	Singleturn bit number* (X3):	Multiturn bit number* (X4):	Output code (X5):	Cable length (X6):	Connector type (X7):
ST - singleturn MT - multiturn	S - SSI B - BiSS C	B9 - 9 B10 - 10 B11 - 11 B12 - 12 ..... B20 - 20 B21 - 21	M0 - 0 (for singleturn version) M9 - 9 M10 - 10 M11 - 11 M12 - 12 ..... M24 - 40	B - Binary G - Gray	A01 - 1m (A-axial cable) A02 - 2m ..... AR01 - 1m (AR-universal cable outlet) AR02 - 2m AR03 - 3m .....	W - without connector C9 - round, 9 pins C12 - round, 12 pins D9 - flat, 9 pins RS10 - round, 10 pins ONC - round, 10 pi
* See electrical data for possible bit selection with specific interface						
ORDER EXAMPLES: 1) AK36-ST-S-B9/M0-B-AR02/W 2) AK36-MT-B-B20/M12-G-AR01/C12						

# PHOTOELECTRIC ROTARY ENCODER

# AK36HME1



AK36HME1 is a photoelectric absolute encoder that is available in singleturn and multiturn (battery buffered) versions. The encoder has up to 21 bit resolution in singleturn option and up to 40 bit resolution

when using the multiturn version. It outputs the signal through BiSS C or SSI interface and has a blind hollow shaft.

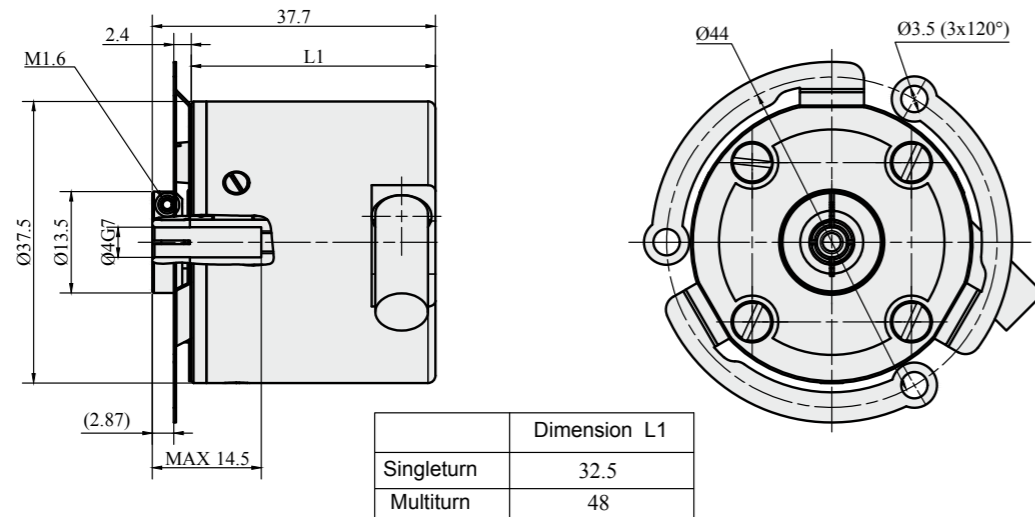

## MOUNTING REQUIREMENTS

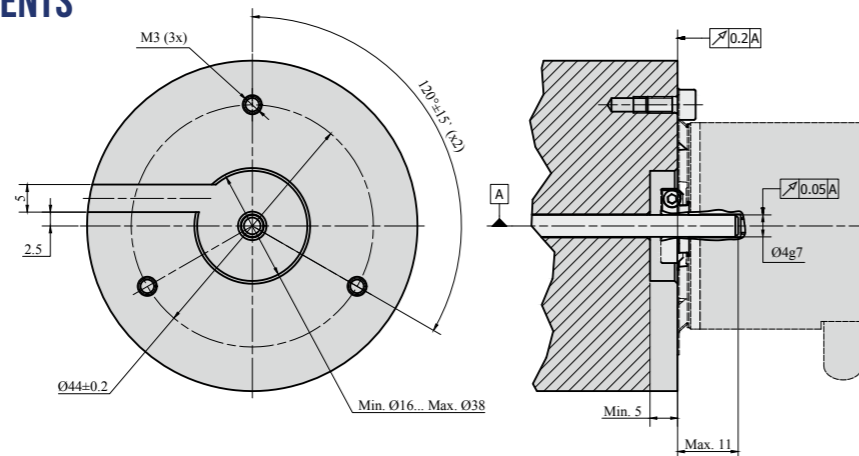

## MECHANICAL DATA

Maximum shaft speed	10000 rpm	Operating temperature:	
Permissible motion of shaft:		- singleturn version	-20...+80 °C
- axial	±0.5 mm	- multiturn version	-10...+70 °C
- radial (at shaft end)	±0.03 mm	Storage temperature:	
Starting torque at 20°C	≤ 0.002 Nm	- singleturn version	-30...+90 °C
Rotor moment of inertia	< 2 gcm <sup>2</sup>	- multiturn version	-20...+80 °C
Protection (IEC 529)	IP54 IP64	Maximum humidity (non-condensing)	98 %
- Standard	IP54	Permissible vibration (55 to 2000 Hz)	≤ 100 m/s <sup>2</sup>
- Optional	IP64	Permissible shock (11 ms)	≤ 300 m/s <sup>2</sup>
Maximum weight without cable	0.1 kg		

## ELECTRICAL DATA

Resolution:		Accuracy	± 30 arc sec
Singleturn version:		Supply voltage	+5V ± 5%
- with interface BiSS C	9... 21 bit	Light source	LED
- with interface SSI	9... 21 bit	Maximum operating frequency:	
Multiturn version:		- with interface BiSS C	10 MHz
- single turn resolution with BiSS C	9... 21 bit	- with interface SSI	4 MHz
- multiturn resolution with BiSS C	12/16/20/24 bit	Cable length (standard)	1 m
- single turn resolution with SSI	9... 21 bit	Maximum cable length	25 m
- multiturn resolution with SSI	9... 40 bit		
Output code	Gray, binary		
Data interface	SSI, BiSS C		

### BiSS C serial interface

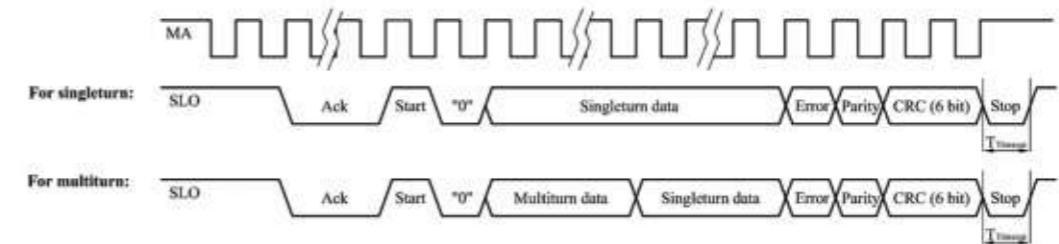

### SSI serial interface

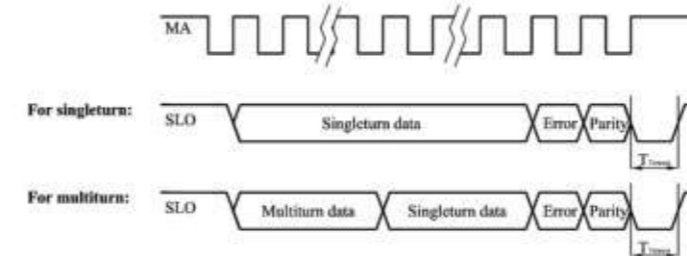

Interface	BiSS C
T <sub>Trans</sub>	1.2 µs - 26 µs
Clock frequency	62.5 kHz - 10 MHz

Interface	SSI
T <sub>Trans</sub>	1.2 µs - 26 µs
Clock frequency	62.5 kHz - 4 MHz

Note:

- Error and parity bits should be determined during order.

## ACCESSORIES

<b>CONNECTORS FOR CABLE</b>	B12 12-pin round connector	C9 12-pin round connector	C12 12-pin round connector	D9 9-pin flat connector	RS10 10-pin round connector	ONC 10-pin round connector
<b>DIGITAL READOUT DEVICES</b>	CS3000			CS5500		
<b>COUPLING</b>				SC30		
<b>EXTERNAL INTERPOLATOR</b>				NK		

## ORDER FORM

AK36HME1 - X1 - X2 - X3/X4 - X5 - X6/X7

Versions (X1):	Output signals Interface (serial) (X2):	Singleturn bit number* (X3):	Multiturn bit number* (X4):	Output code (X5):	Cable length (X6):	Connector type (X7):
ST - singleturn MT - multiturn	S - SSI B - BiSS C	B9 - 9 B10 - 10 B11 - 11 B12 - 12 ... B20 - 20 B21 - 21	M0 - 0 (for singleturn version) M9 - 9 M10 - 10 M11 - 11 M12 - 12 ... M40 - 40	B - Binary G - Gray	A01 - 1m (A-axial cable) A02 - 2m ... AR01 - 1m (AR-universal cable outlet) AR02 - 2m ... ...	W - without connector B12 - round, 12 pins C9 - round, 9 pins C12 - round, 12 pins D9 - flat, 9 pins RS10 - round, 10 pins ONC - round, 10 pi

\* See electrical data for possible bit selection with specific interface

ORDER EXAMPLES: 1) AK36HME1-ST-S-B9/M0-B-AR02/W  
2) AK36HME1-MT-B-B20/M12-G-AR01/C12

# PHOTOELECTRIC ROTARY ENCODER

# A42M



Analog output signals



Modular



Photoelectric modular rotary encoder A42M is of incremental type and provides up to 25.000 output pulses per revolution. The absence of bearings and lubricants makes the encoder suitable for

use in vacuum environment or situations when zero starting torque is required.

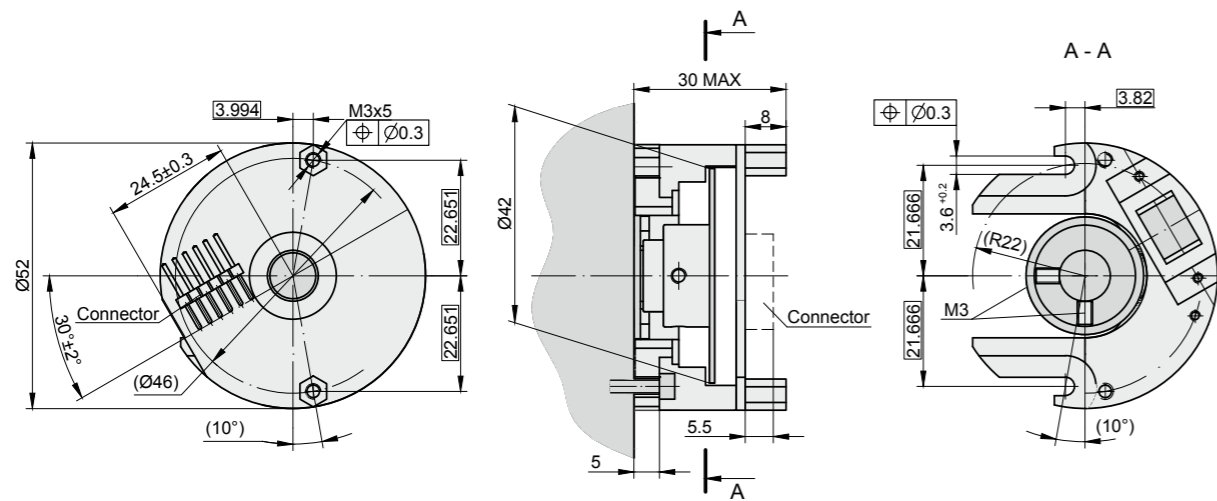

## MECHANICAL DATA

Line number on disc (z)	1000, 2500 (others on request)	Protection (IEC 529)	IP00
Number of output pulses per revolution for A42M-F	Z x k, where k=1,2, 3, 4, 5, 8, 10	Max. weight: - rotor assembly - scanning unit	0.022 kg 0.04 kg
Max. permissible mechanical rotation speed	20000 rpm	Operating temperature	-10...+70 °C
Accuracy (T1-period of lines on disc in arc. sec.)	±0.1T1 arc. sec.	Storage temperature	-30...+85 °C
Permissible axial shaft run out	0.05 mm	Maximum humidity (non-condensing)	98 %
Hub inside diameter	10, 8, 6 mm	Permissible vibration (55 to 2000 Hz)	< 100 m/s <sup>2</sup>
Rotor moment of inertia	< 22 gcm <sup>2</sup>	Permissible shock (6 ms)	< 1000 m/s <sup>2</sup>

## ACCESSORIES

CONNECTORS FOR CABLE	B12 12-pin round connector	C9 9-pin round connector	C12 12-pin round connector	D9 9-pin flat connector	D15 15-pin flat connector	RS10 10-pin round connector	ONC 10-pin round connector
CONNECTOR FOR PCB	Adapter Cable dia. 6,2 mm with PCB connector						
DIGITAL READOUT DEVICES	CS3000			CS5500			
EXTERNAL INTERPOLATOR	NK						

## ELECTRICAL DATA

VERSION	A42M-A ~ 11 µApp	A42M-AV ~ 1Vpp	A42M-F □□ TTL
Power supply	+5V ± 5% / < 80 mA	+5V ± 5% / < 120 mA	+5V ± 5% / < 120 mA
Light source	LED	LED	LED
Incremental signals	Two sinusoidal I <sub>1</sub> and I <sub>2</sub> Amplitude at 1 kΩ load: - I <sub>1</sub> = 7-16 µA - I <sub>2</sub> = 7-16 µA	Differential sine +A/-A and +B/-B Amplitude at 120 Ω load: - A = 0.6-1.2 V - B = 0.6-1.2 V	Differential square-wave U1/U1 and U2/U2. Signal levels at 20 mA load current: - low (logic "0") < 0.5 V - high (logic "1") > 2.4 V
Reference signal	One quasi-triangular I <sub>0</sub> peak per revolution. Signal magnitude 1 kΩ load: - I <sub>0</sub> = 2-8 µA (usable)	One quasi-triangular +R and its complementary -R per revolution. Signals magnitude at 120 Ω load - R = 0.2-0.8 V (usable)	One differential square-wave U0/U0 per revolution. Signal levels at 20 mA load current: - low (logic "0") < 0.5 V - high (logic "1") > 2.4 V
Maximum operating frequency	(-3 dB) ≥ 160 kHz	(-3 dB) ≥ 180 kHz	(160 x k) kHz, k-interpolation factor
Direction of signals	I <sub>2</sub> lags I <sub>1</sub> for clockwise rotation (viewed from shaft side)	+B lags +A for clockwise rotation (viewed from shaft side)	U2 lags U1 with clockwise rotation (viewed from shaft side)
Maximum rise and fall time	-	-	< 0.5 µs
Recommended max. cable length to subsequent electronics	5 m	25 m	25 m
Output signals			

Note:

- Maximum working rotation speed (with proper encoder counting) is limited by maximum operating frequency and maximum mechanical rotation speed.
- If cable extension is used, power supply conductor cross-section should not be smaller than 0.5 mm<sup>2</sup>.

## MOUNTING DIMENSIONS

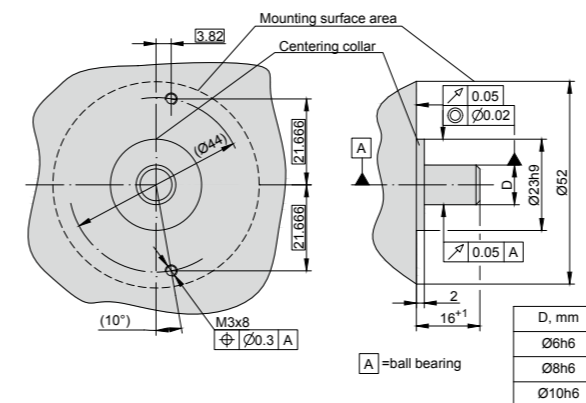

## PCB CONNECTOR

**AC**  
Adapter Cable dia.  
6,2 mm with PCB connector

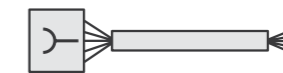

## ORDER FORM

Output signal Version (X1):	Pulse number Per revolution (X2):	(Optional) line number on disc (z) (X3):	Hub inside Diameter (X4):	Adapter cable (X5):	Connector type for adapter cable (X6):
<b>AV</b> <b>F</b>	<b>1000</b> ... <b>25000*</b>	<b>1000</b> <b>2500</b> *only for A42M-F	<b>06</b> - Ø 6mm <b>08</b> - Ø 8mm <b>10</b> - Ø 10mm	<b>W</b> - without cable <b>AC01</b> - 1m <b>AC02</b> - 2m <b>AC03</b> - 3m ...	<b>W</b> - without connector <b>B12</b> - round, 12 pins <b>C9</b> - round, 9 pins <b>C12</b> - round, 12 pins <b>D9</b> - flat, 9 pins <b>D15</b> - flat, 15 pins <b>RS10</b> - round, 10 pins <b>ONC</b> - round, 10 pins
ORDER EXAMPLES: 1) A42M-AV-2500-10-AC01/W 2) A42M-F-5000-06-/W/W 3) A42M-F-5000/1000-06-W/W					



PHOTOELECTRIC ROTARY ENCODER

# A75M



Analog output signals



Modular



Photoelectric modular rotary encoder A75M is a wider diameter incremental encoder than A42M, as it is the main difference between these two open-type encoders.

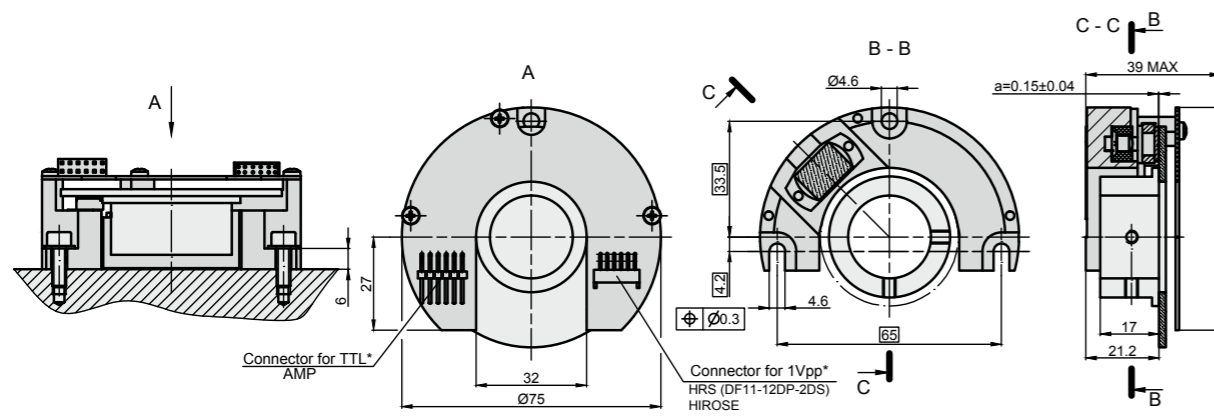

## MECHANICAL DATA

Line number on disc (z)	512; 2048; 5000 (others on request)	Protection (IEC 529)	IP00
Number of output pulses per revolution for A75M-F	Z x k, where k= 1, 2, 3, 4, 5, 8, 10	Max. weight	0.2 kg
Max. permissible mechanical rotation speed	16000 rpm	Operating temperature	0...+85 °C
Accuracy (T <sub>1</sub> period of lines on disc in arc. sec.)	±0.1T <sub>1</sub> arc. sec.	Storage temperature	-30...+85 °C
Permissible axial shaft run out	±0.05 mm	Maximum humidity (non-condensing)	98 %
Rotor moment of inertia: - with shaft Ø 20 mm - with shaft Ø 30 mm	26x10 <sup>-6</sup> kgm <sup>2</sup> 35x10 <sup>-6</sup> kgm <sup>2</sup>	Permissible vibration (55 to 2000 Hz)	≤ 100 m/s <sup>2</sup>
		Permissible shock (6 ms)	≤ 1000 m/s <sup>2</sup>

## ACCESSORIES

CONNECTORS FOR CABLE	B12 12-pin round connector	C12 12-pin round connector	D9 9-pin flat connector	D15 15-pin flat connector	RS10 10-pin round connector	ONC 10-pin round connector
CONNECTOR FOR PCB	Adapter Cable dia. 6,2 mm with PCB connector					
DIGITAL READOUT DEVICES	CS3000		CS5500			
EXTERNAL INTERPOLATOR	NK					

## ELECTRICAL DATA

VERSION	A75M-AV ~ 1Vpp	A75M-F □ □ TTL
Power supply	+5 V ± 5% / < 120 mA	+5 V ± 5% / < 120 mA
Light source	LED	LED
Incremental signals	Differential sine +A/-A and +B/-B Amplitude at 120 Ω load: - A = 0.6-1.2 V - B = 0.6-1.2 V	Differential square-wave U1/U1̄ and U2/U2̄. Signal levels at 20 mA load current: - low (logic "0") ≤ 0.5 V - high (logic "1") ≥ 2.4 V
Reference signal	One quasi-triangular +R and its complimentary -R per revolution. Signal magnitude at 120 Ω load: - R = 0.2...0.8 V (usable)	One differential square-wave U0/U0̄ per revolution. Signal levels at 20 mA load current: - low (logic "0") ≤ 0.5 V - high (logic "1") ≥ 2.4 V
Maximum operating frequency	(-3 dB) ≥ 180 kHz	(160 x k) kHz, k - interpolation factor
Direction of signals	+B lags +A for clockwise rotation (viewed from shaft side)	U2 lags U1 for clockwise rotation (viewed from shaft side)
Maximum rise and fall time	-	< 0.5 μs
Recommended max. cable length to subsequent electronics	25 m	25 m
Output signals		

## MOUNTING DIMENSIONS

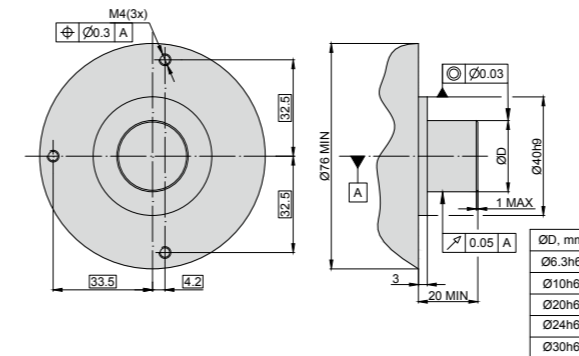

## PCB CONNECTOR

**AC**  
Adapter Cable dia.  
6,2 mm with PCB connector



## ORDER FORM

Output signal Version (X1):	Pulse number Per revolution (X2):	(Optional) line number on disc (z) (X3):	Hub inside diameter (X4):	Adapter cable (X5):	Connector type for adapter cable (X6):
AV F	512 5000*	512 2048 5000	06 - Ø 6.3mm 10 - Ø 10mm 20 - Ø 20mm 24 - Ø 24mm 30 - Ø 30mm	W - without cable AC01 - 1m AC02 - 2m AC03 - 3m ...	W - without connector B12 - round, 12 pins C12 - round, 12 pins D9 - flat, 9 pins D15 - flat, 15 pins RS10 - round, 10 pins ONC - round, 10 pins
*only F signal version for >5000 pulses					
ORDER EXAMPLES: 1) A75M-F-4096-24-AC01/W 2) A75M-F-4096/512-24-AC01/W					

# PHOTOELECTRIC ROTARY ENCODER

# AK50



Photoelectric absolute rotary encoder AK50 is manufactured containing up to 8 bit resolution via Gray, binary or other custom code output. It uses photoelectric technology and provides the user with

an ability to set arbitrary reference position accessible via switch of up to 256 indexed positions.

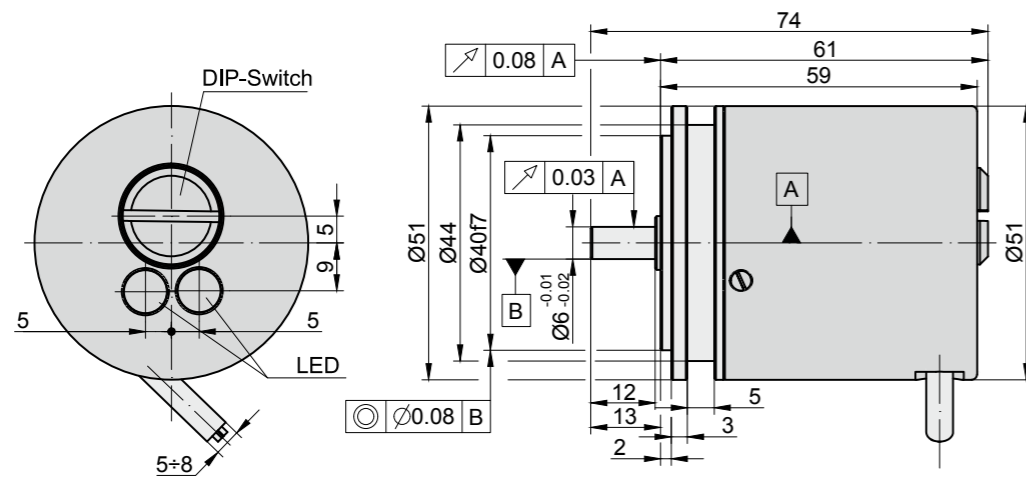

## MECHANICAL DATA

Maximum shaft speed without counting loss for 8 bit	3000 rpm	Operating temperature	-20...+80 °C
Maximum shaft load: - axial - radial (at shaft end)	80 N 100 N	Storage temperature	-30...+90 °C
Starting torque at 20 °C	3 Ncm	Maximum humidity (non-condensing)	98 %
Rotor moment of inertia	20 gcm <sup>2</sup>	Permissible vibration (55 to 2000 Hz)	≤ 100 m/s <sup>2</sup>
Protection (IEC 529): - housing - shaft	IP66 IP65	Permissible shock (11 ms)	≤ 1000 m/s <sup>2</sup>
Maximum weight without cable	0.3 kg		

## ACCESSORIES

CONNECTORS FOR CABLE	B12	C9	C12	D9	D15	RS10	ONC
	12-pin round connector	9-pin round connector	12-pin round connector	9-pin flat connector	15-pin flat connector	10-pin round connector	10-pin round connector
COUPLING	SC30						

## ELECTRICAL DATA

Accuracy	±120 arc. sec
Resolution	2 <sup>n</sup> (256)
Code:	Gray, Binary
Output signals interface	Parallel
Light source	LED
Supply voltage: - standard - optional	+24 (8...25) V± 5% +5 V± 5%
Maximum supply current	50 mA
Output signal levels	TTL/HTL
Maximum cable length	25 m

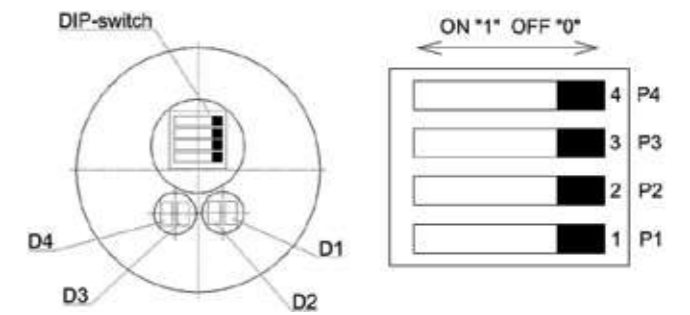

P1, P2, P3, P4 - operating mode and first setting switches;  
D1 - green LED for indication of counting origin on code disc;  
D2 - yellow LED for indication of specified counting origin;  
D3 - red LED for indication of encoder failure:  
- incorrect supply voltage,  
- counting error,  
- LED failure;  
D4 - green LED for indication of proper encoder operating

Strobe	1 Bit	2 Bit	3 Bit	4 Bit	5 Bit	Parity-Check
1	1	1	1	1	1	1
0	0	0	0	0	0	0
1	0	1	0	1	1	1
0	1	0	1	0	0	0
1	0	1	1	0	0	0
0	1	0	0	1	1	1
1	0	0	0	0	0	0
0	1	1	1	1	1	1
1	0	0	1	0	0	0
0	1	1	0	1	1	1

Switches position depending on tool number in tool changer

Tool number in tool changer	Switch P1 position	Switch P2 position
8	0	0
12	0	1
16	1	0
24	1	1

Encoder code full truth table (24 positions)

Function	Indexing position of turret																							
	1	2	3	4	5	6	7	8	9	10	11	12	13	14	15	16	17	18	19	20	21	22	23	24
Strobe	1	1	1	1	1	1	1	1	1	1	1	1	1	1	1	1	1	1	1	1	1	1	1	1
1 Bit	1	0	1	0	1	0	1	0	1	0	1	0	1	0	1	0	1	0	1	0	1	0	1	0
2 Bit	0	1	1	0	0	1	1	0	0	1	1	0	0	1	1	0	0	1	1	0	0	1	1	0
3 Bit	0	0	0	1	1	1	1	0	0	0	0	1	1	1	1	0	0	0	0	1	1	1	1	0
4 Bit	0	0	0	0	0	0	0	1	1	1	1	1	1	1	1	0	0	0	0	0	0	0	0	1
5 Bit	0	0	0	0	0	0	0	0	0	0	0	0	0	0	0	1	1	1	1	1	1	1	1	1
Parity-check	1	1	0	1	0	0	1	1	0	0	1	0	1	1	0	1	0	0	1	0	1	1	0	0

## ORDER FORM

AK50 - X1 - X2/X3 - X4 - X5 - X6/X7

Configuration type (X1):	Number of positions* (X2):	(Or) number of bits* (X3):	Output code (X4):	Supply voltage (X5):	Cable length (X6):	Connector type (X7):
P - POSITION NUMBER B - BIT NUMBER	2 ...	1 2 ...	G - gray B - binary	05V - +5V 24V - +(8...25)V	AR01 - 1m AR02 - 2m AR03 - 3m ...	W - without connector B12 - round, 12 pins C9 - round, 9 pins C12 - round, 12 pins D9 - flat, 9 pins D15 - flat, 15 pins RS10 - round, 10 pins ONC - round, 10 pins

ORDER EXAMPLES:  
1) AK50-P-8/12/16/24-G-24V-AR01/W  
2) AK50-B-8-G-05V-AR02/W  
3) AK50-P-16/32-B-05V-AR12/C12  
4) AK50-B-5/6/8-G-24V-AR06/W

PHOTOELECTRIC ROTARY ENCODER

# A58



The A58 series is a photoelectric incremental encoder series that is comprised of 6 iterations – A58M, A58B, A58C, A58C2, A58C3 and A58D. These encoders share the same mechanical and electrical characteristics but differ in mounting options. Encoders produce up

to 108.000 output pulses per revolution and depending on customer demands can have different versions of output signals: 11uApp, 1Vpp, TTL or HTL.

## A58M

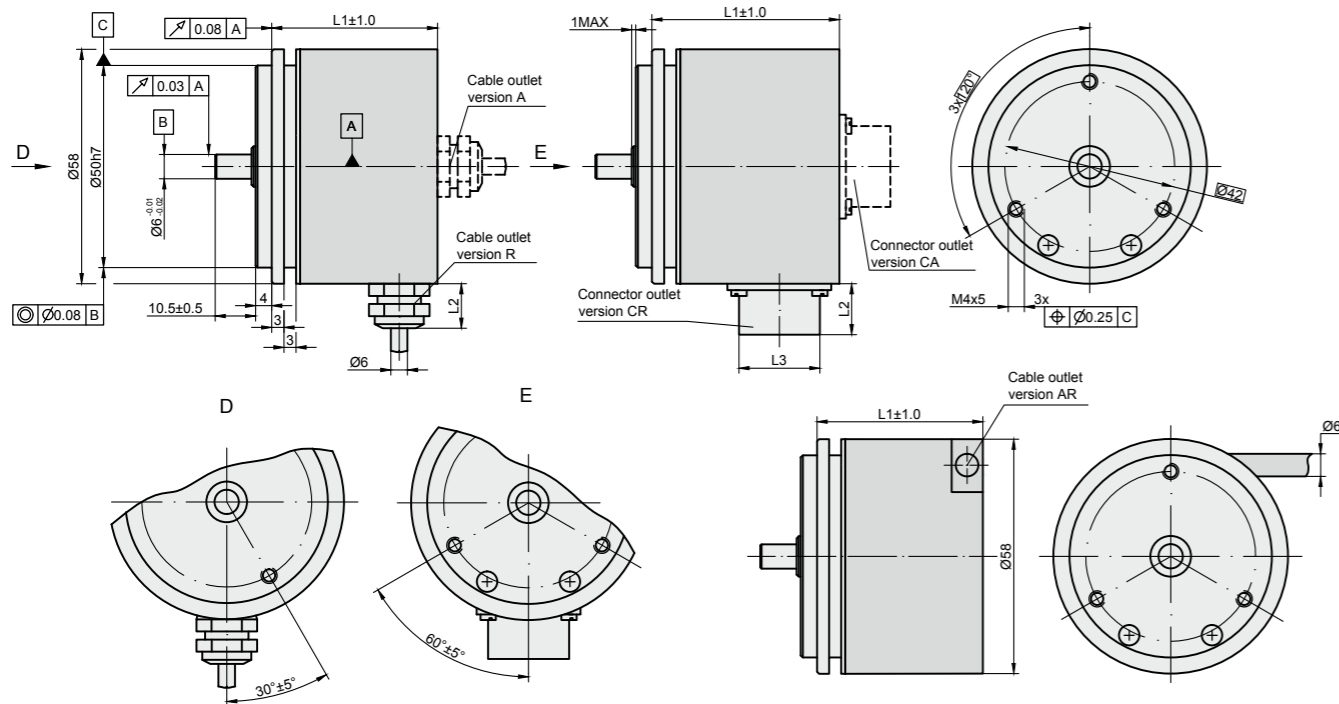

Other mounting versions can be found in the next pages

Connector type / cable outlet	ONC axial	RS10 axial	C12, C9 axial	ONC radial	RS10 radial	C12, C9 radial	Cable axial (ver. A)	Cable radial (ver. R)	Cable axial-radial (ver. AR)
L1	41 mm	41 mm	41 mm	54 mm	53 mm	53 mm	41 mm	41 mm	43 mm
L2	16 mm	9 mm	22 mm	16 mm	9 mm	22 mm	12 mm	12 mm	-
L3	M24	M14	M23	M24	M14	M23	-	-	-

## MECHANICAL DATA

Line number on disc (z)	100; 250; 500; 600; 800; 1000; 1024; 1125; 1250; 1500; 2000; 2048; 2500; 3000; 3600; 4000; 5000; 9000; 10800	Starting torque at 20°C	≤ 0.01 Nm
Pulse number per shaft revolution for A58-F	Z x k, where k=1,2,3,4,5,8,10	Rotor moment of inertia	< 15 gcm <sup>2</sup>
Maximum shaft speed	12000 rpm	Protection (IEC 529)	IP64
Maximum shaft load:		Maximum weight without cable	0.25 kg
- axial	40 N	Operating temperature	-10...+70 °C
- radial (at shaft end)	60 N	Storage temperature	-30...+80 °C
Accuracy (T <sub>1</sub> -period of lines on disc in arc. sec)	±0.1T <sub>1</sub> arc. sec	Maximum humidity (non-condensing)	98 %
		Permissible vibration (55 to 2000 Hz)	≤ 100 m/s <sup>2</sup>
		Permissible shock (11 ms)	≤ 1000 m/s <sup>2</sup>

## ACCESSORIES

<b>CONNECTORS FOR CABLE</b>	B12 12-pin round connector	C9 9-pin round connector	C12 12-pin round connector	D9 9-pin flat connector	D15 15-pin flat connector	RS10 10-pin round connector	ONC 10-pin round connector
<b>CONNECTORS ON HOUSING</b>	C9 9-pin round connector		C12 12-pin round connector	RS10 10-pin round connector		ONC 10-pin round connector	
<b>DIGITAL READOUT DEVICES</b>	CS3000			CS5500			
<b>COUPLING</b>				SC30			
<b>EXTERNAL INTERPOLATOR</b>				NK			

## ELECTRICAL DATA

Version	A58-A ~ 11 µApp	A58-AV ~ 1 Vpp	A58-F □ TTL; □ HTL
Supply voltage (U <sub>p</sub> )	+5 V ±5%	+5 V ±5%	+5 V ±5%; +(10 to 30) V
Max. supply current (without load)	80 mA	120 mA	120 mA
Light source	LED	LED	LED
Incremental signals	Two sinusoidal I <sub>1</sub> and I <sub>2</sub> Amplitude at 1 kΩ load: - I <sub>1</sub> = 7-16 µA - I <sub>2</sub> = 7-16 µA	Differential sine +A/-A and +B/-B Amplitude at 120 Ω load: - A = 0.6-1.2 V - B = 0.6-1.2 V	Differential square-wave U1/U1 and U2/U2. Signal levels at 20 mA load current: - low (logic "0") ≤ 0.5 V at U <sub>p</sub> =+5 V - low (logic "0") ≤ 1.5 V at U <sub>p</sub> =10 to 30 V - high (logic "1") ≥ 2.4 V at U <sub>p</sub> =+5 V - high (logic "1") ≥ (U <sub>p</sub> -2) V at U <sub>p</sub> =10 to 30 V
Reference signal	One quasi-triangular I <sub>0</sub> peak per revolution. Signal magnitude at 1 kΩ load: - I <sub>0</sub> = 2-8 µA (usable component)	One quasi-triangular +R and its complementary -R per revolution. Signal magnitude at 120 Ω load - R = 0.2-0.8 V (usable component)	One differential square-wave U0/U0 per revolution. Signal levels at 20 mA load current: - low (logic "0") < 0.5 V at U <sub>p</sub> =+5 V - low (logic "0") < 1.5 V at U <sub>p</sub> =10 to 30 V - high (logic "1") > 2.4 V at U <sub>p</sub> =+5 V - high (logic "1") > (U <sub>p</sub> -2) V at U <sub>p</sub> =10 to 30 V
Maximum operating frequency	(-3 dB) ≥ 160 kHz	(-3 dB) ≥ 180 kHz	(160 x k) kHz, k-interpolation factor
Direction of signals	I <sub>1</sub> lags I <sub>2</sub> for clockwise rotation (viewed from shaft side)	+B lags +A for clockwise rotation (viewed from shaft side)	U2 lags U1 with clockwise rotation (viewed from shaft side)
Maximum rise and fall time	-	-	< 0.5 µs
Standard cable length	1 m, without connector	1 m, without connector	1 m, without connector
Maximum cable length	5 m	25 m	25 m
Output signals			

Note:

- Maximum working rotation speed (with proper encoder counting) is limited by maximum operating frequency and maximum mechanical rotation speed.
- If cable extension is used, power supply conductor cross-section should not be smaller than 0.5 mm<sup>2</sup>.



# A58B

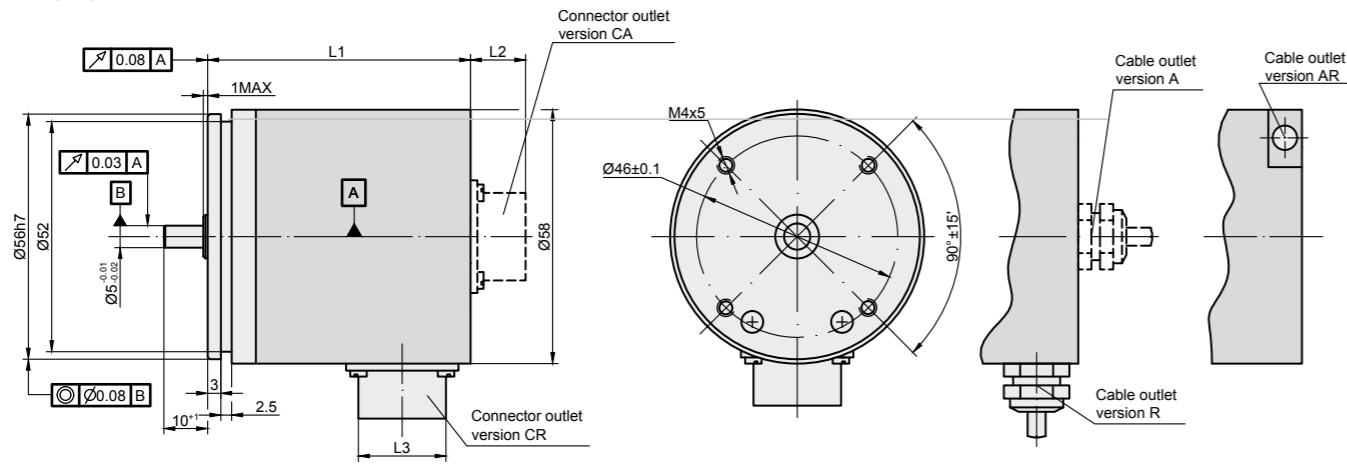

Connector type / cable outlet	ONC axial	RS10 axial	C12, C9 axial	ONC radial	RS10 radial	C12, C9 radial	Cable axial (ver. A)	Cable radial (ver. R)	Cable axial-radial (ver. AR)
L1	44.5 mm	44.5 mm	44.5 mm	57.5 mm	56.5 mm	56.5 mm	44.5 mm	44.5 mm	46.6 mm
L2	16 mm	9 mm	22 mm	16 mm	9 mm	22 mm	12 mm	12 mm	-
L3	M24	M14	M23	M24	M14	M23	-	-	-

# A58C

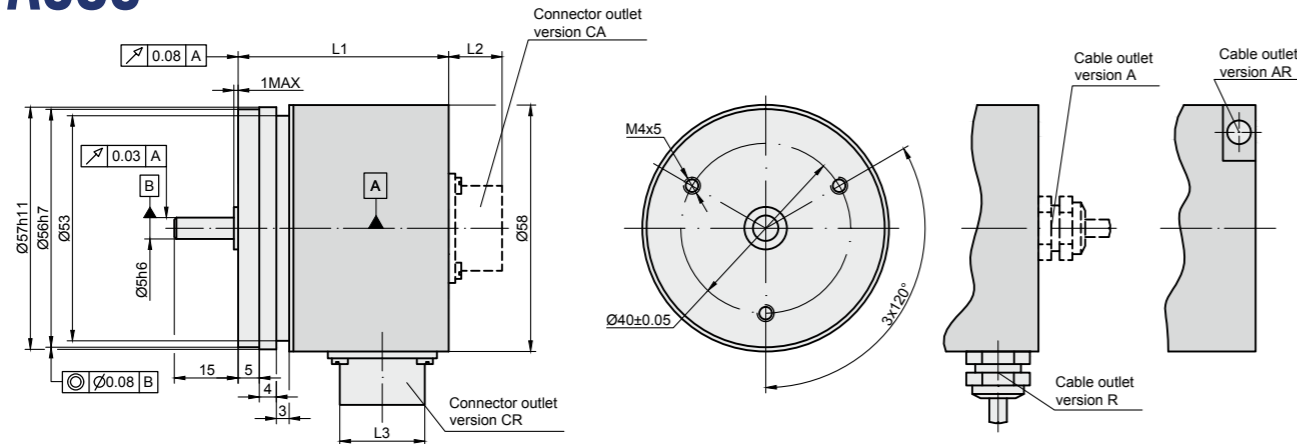

Connector type / cable outlet	ONC axial	RS10 axial	C12, C9 axial	ONC radial	RS10 radial	C12, C9 radial	Cable axial (ver. A)	Cable radial (ver. R)	Cable axial-radial (ver. AR)
L1	47 mm	47 mm	47 mm	60 mm	59 mm	59 mm	47 mm	47 mm	49 mm
L2	16 mm	9 mm	22 mm	16 mm	9 mm	22 mm	12 mm	12 mm	-
L3	M24	M14	M23	M24	M14	M23	-	-	-

# A58C2

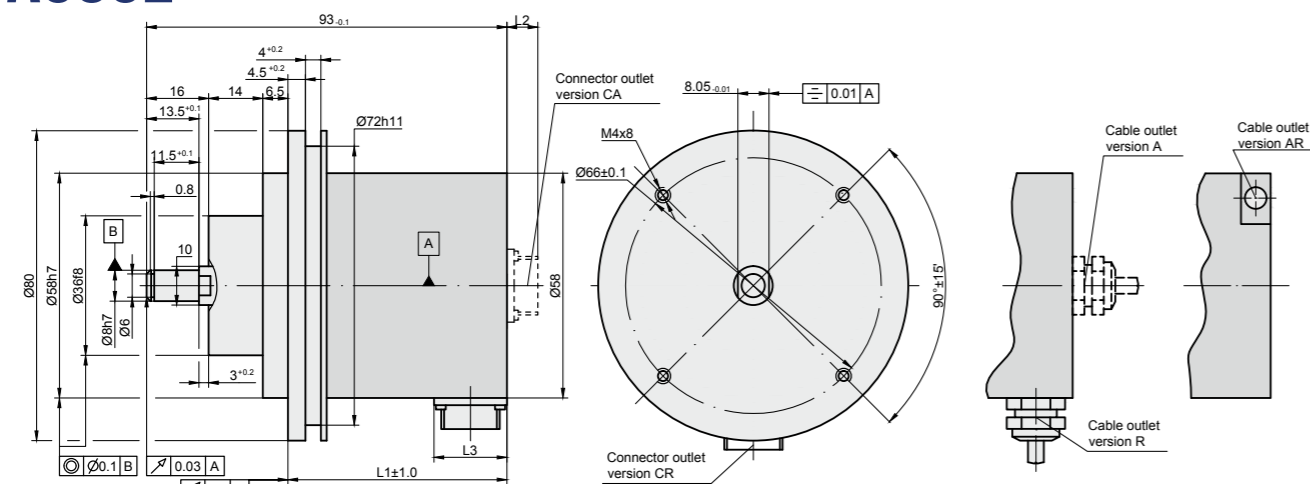

Connector type / cable outlet	ONC axial	RS10 axial	C12, C9 axial	ONC radial	RS10 radial	C12, C9 radial	Cable axial (ver. A)	Cable radial (ver. R)	Cable axial-radial (ver. AR)
L1	44.5 mm	44.5 mm	44.5 mm	-	56.5 mm	56.5 mm	44.5 mm	44.5 mm	46.5 mm
L2	16 mm	9 mm	22 mm	16 mm	9 mm	22 mm	12 mm	12 mm	-
L3	M24	M14	M23	M24	M14	M23	-	-	-

# A58C3

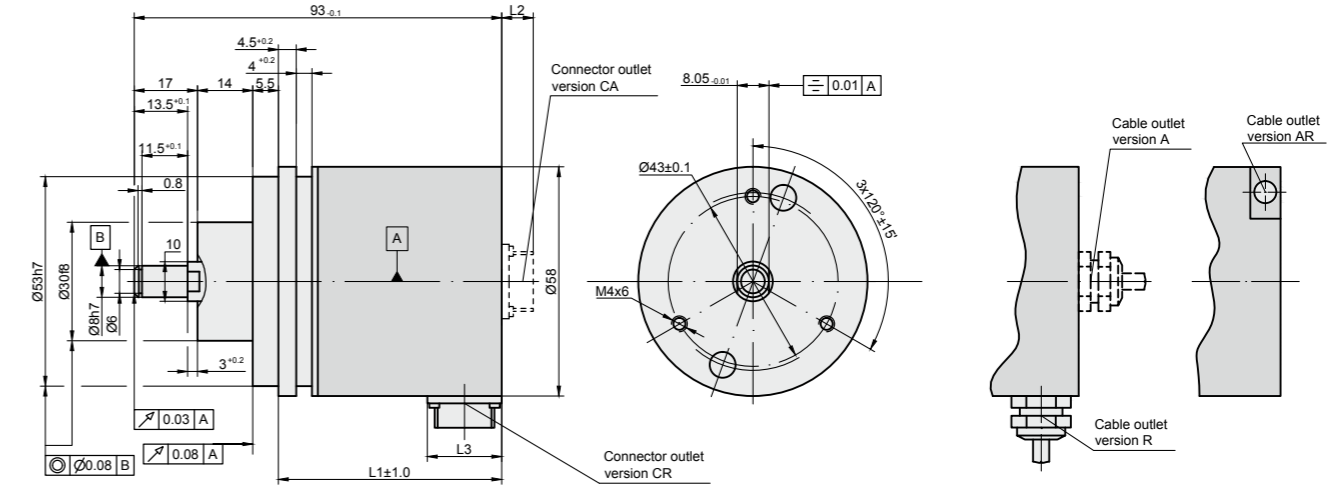

Connector type / cable outlet	ONC axial	RS10 axial	C12, C9 axial	ONC radial	RS10 radial	C12, C9 radial	Cable axial (ver. A)	Cable radial (ver. R)	Cable axial-radial (ver. AR)
L1	50 mm	50 mm	50 mm	-	62 mm	62 mm	50 mm	50 mm	52 mm
L2	16 mm	9 mm	22 mm	16 mm	9 mm	22 mm	12 mm	12 mm	-
L3	M24	M14	M23	M24	M14	M23	-	-	-

# A58D

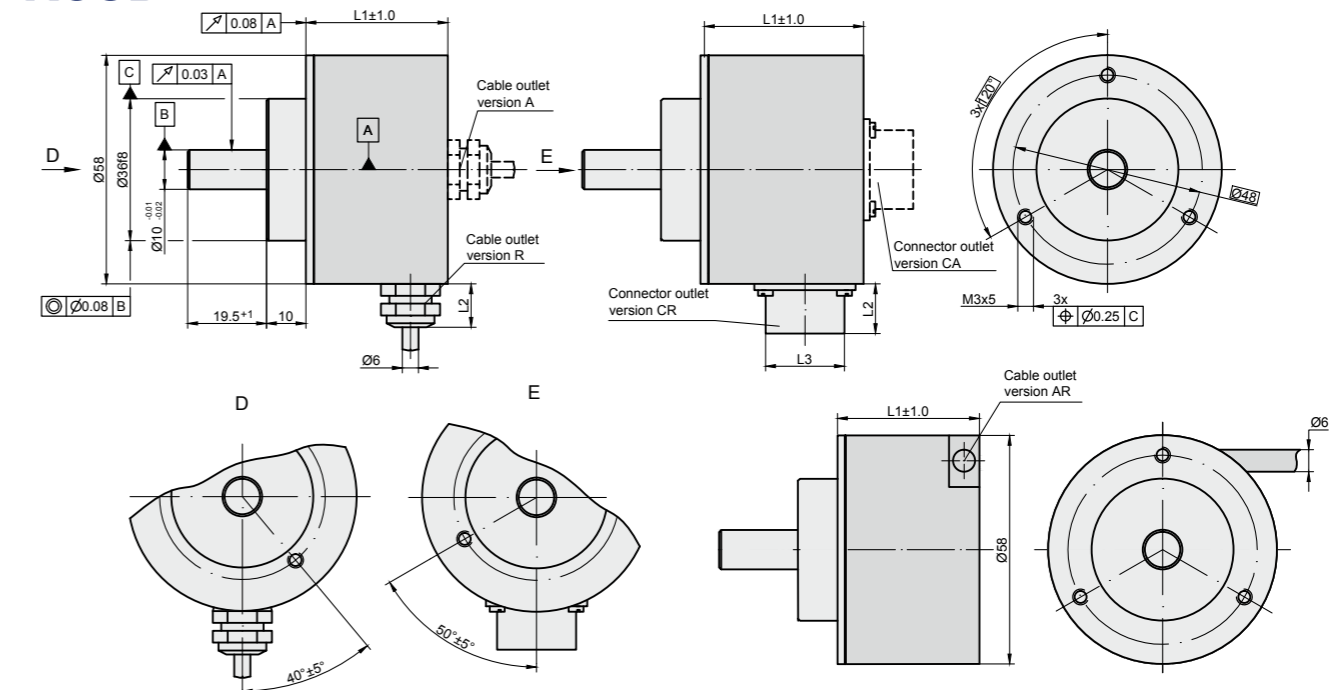

Connector type / cable outlet	ONC axial	RS10 axial	C12, C9 axial	ONC radial	RS10 radial	C12, C9 radial	Cable axial (ver. A)	Cable radial (ver. R)	Cable axial-radial (ver. AR)
L1	37.5 mm	37.5 mm	37.5 mm	-	49.5 mm	49.5 mm	37.5 mm	37.5 mm	39.5 mm
L2	16 mm	9 mm	22 mm	16 mm	9 mm	22 mm	12 mm	12 mm	-
L3	M24	M14	M23	M24	M14	M23	-	-	-

## ORDER FORM

A58 - X1 - X2 - X3/X4 - X5 - X6/X7

Type (X1):	Output signals version (X2):	Pulse number per revolution (X3):	Optional line number on disc (z) (X4):	Supply voltage (X5):	Cable length and outlet or flange socket on case outlet (X6):	Connector or flange Socket type (X7):
M - A58M B - A58B C - A58C C2 - A58C2 C3 - A58C3 D - A58D	A AV F	100 ... 108000*	100 ... 10800	05V - +5V 30V - +(10 to 30)V*	A01 - 1m (A-axial cable) A02 - 2m R03 - 3m (R-radial cable) AR01 - 1 m (AR-universal cable outlet) CA - flange socket axial CR - flange socket radial	W - without connector D9 - flat, 9 pins C9 - round, 9 pins C12 - round, 12 pins RS RS10 - round, 10 pins ONC - round, 10 pins

ORDER EXAMPLES: 1) A58M-A-1024-05V-A01/W  
2) A58B-F-2500-05V-AR01/W  
3) A58B-F-2500/500-05V-AR01/W

PHOTOELECTRIC ROTARY ENCODER

# AK58



Photoelectric absolute singleturn and multiturn rotary encoder series AK58 is constituted of 6 different models - AK58M, AK58B, AK58C, AK58C2, AK58C3 and AK58D. Encoders use SSI and BiSS

output signal interfaces and output up to 24 bit singleturn and 40 bit multiturn resolutions through binary or Gray codes.

## AK58M

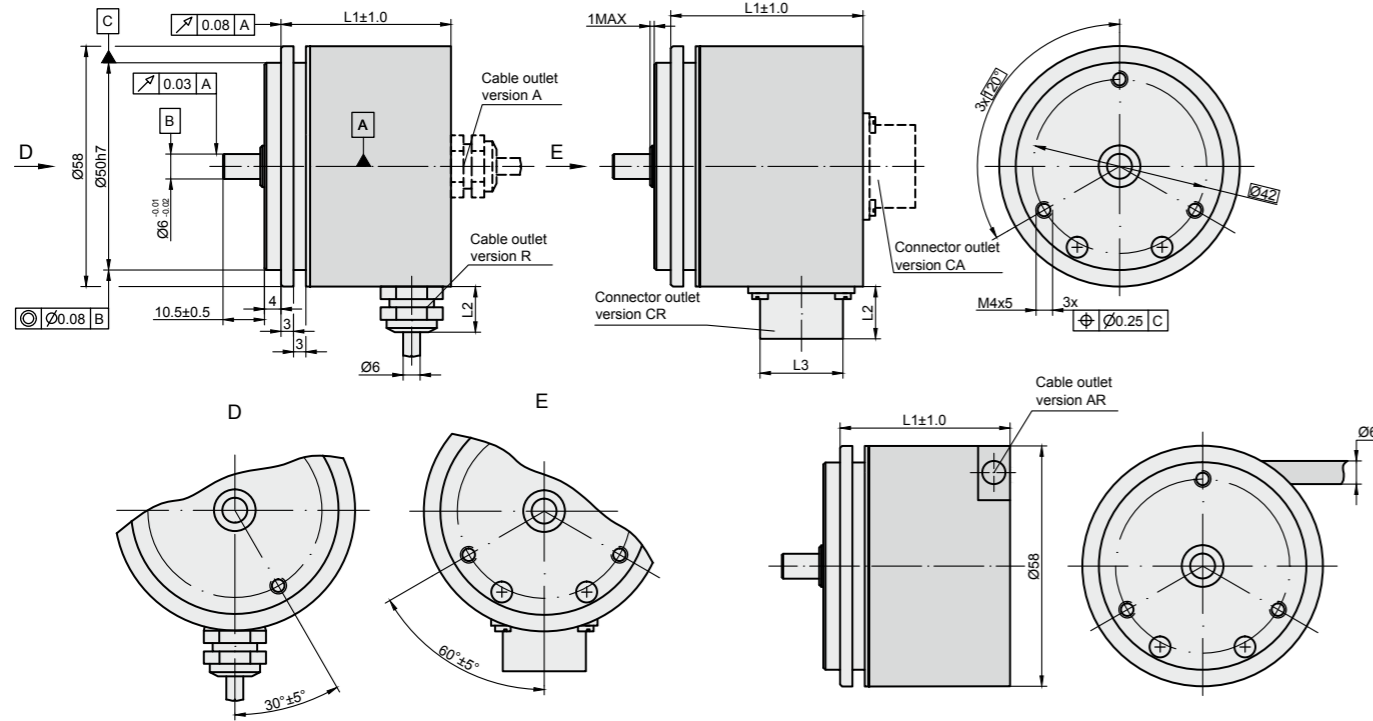

OTHER MOUNTING VERSIONS CAN BE FOUND IN THE NEXT PAGES

	Connector type / cable outlet	ONC axial	PC10 axial	C12, C9 axial	ONC radial	PC10 radial	C12, C9 radial	Cable axial (ver. A)	Cable radial (ver. R)	Cable axial-radial (ver. AR)
Singleturn	L1	41 mm	41 mm	41 mm	63 mm	55 mm	58 mm	41 mm	41 mm	43 mm
Multiturn	L1	62 mm	62 mm	62 mm	63 mm	55 mm	58 mm	62 mm	53 mm	55
Singleturn/multiturn	L2	16 mm	9 mm	22 mm	16 mm	9 mm	22 mm	12 mm	12 mm	-
Singleturn/multiturn	L3	M24	M14	M23	M24	M14	M23	-	-	-

## MECHANICAL DATA

Maximum shaft speed	12000 rpm	Maximum weight without cable	0.35 kg
Maximum shaft load: - axial	10 N (40 N for AK58C2, AK58C3, AK58D)	Operating temperature - singleturn version - multiturn version	-20...+80 °C -10...+70 °C
- radial (at shaft end)	20 N (60 N for AK58C2, AK58C3, AK58D)	Storage temperature - singleturn version - multiturn version	-30...+90 °C -20...+80 °C
Starting torque at 20°C	≤ 0.01 Nm	Maximum humidity (non-condensing)	98 %
Rotor moment of inertia	<15 gcm <sup>2</sup>	Permissible vibration (55 to 2000 Hz)	≤ 100 m/s <sup>2</sup>
Protection (IEC 529):	IP65	Permissible shock (11 ms)	≤ 1000 m/s <sup>2</sup>

## ACCESSORIES

<b>CONNECTORS FOR CABLE</b>	B12 12-pin round connector	C9 9-pin round connector	C12 12-pin round connector	D9 9-pin flat connector	D15 15-pin flat connector	RS10 10-pin round connector	ONC 10-pin round connector
<b>CONNECTORS ON HOUSING</b>	C9 9-pin round connector		C12 12-pin round connector	RS10 10-pin round connector		ONC 10-pin round connector	
<b>COUPLING</b>	SC30						

## ELECTRICAL DATA

Resolution: Singleturn version: - with interface BiSS C - with interface SSI	9 ... 21 bit 9 ... 21 bit	Periods number of signals 1Vpp	4096
Multiturn version: - single turn resolution with BiSS C - multiturn resolution with BiSS C - single turn resolution with SSI - multiturn resolution with SSI	9 ... 21 bit 12/16/20/24 bit 9 ... 21 bit 9 ... 40 bit	Accuracy	± 30 arc sec
Output code	Gray, binary	Supply voltage	+5V ± 5%; +(10 to 30) V
Data interface	SSI, BiSS C	Light source	LED
Incremental signals	sine wave (sin, cos) 1 Vpp* (optional) *only for singleturn version	Maximum operating frequency - with interface BiSS C - with interface SSI	up to 10 MHz up to 4 MHz
		Cable length (standard)	1 m

# ELECTRICAL SIGNALS

## BiSS C serial interface

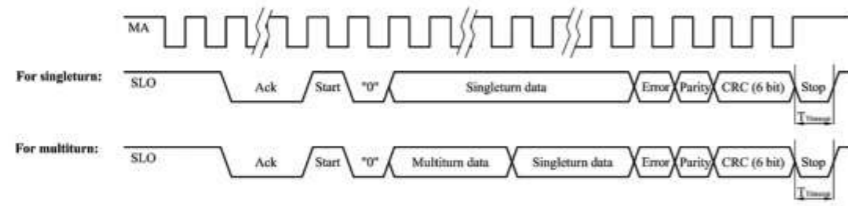

Interface	BiSS C
T <sub>TD</sub>	1,2 µs - 26 µs
Clock frequency	62,5 kHz ÷ 10 MHz

## SSI serial interface

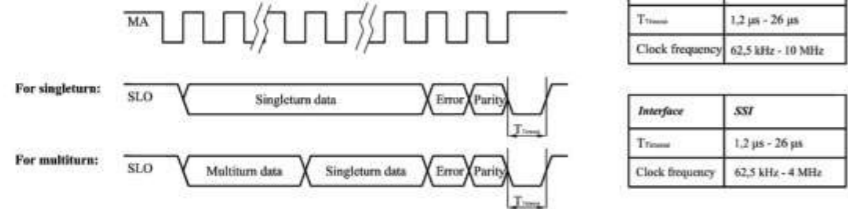

Interface	BiSS C
T <sub>rise</sub>	1,2 µs - 26 µs
Clock frequency	62,5 kHz - 10 MHz

Interface	SSI
T <sub>rise</sub>	1,2 µs - 26 µs
Clock frequency	62,5 kHz - 4 MHz

Interface	SSI
T <sub>TD</sub>	1,2 µs - 26 µs
Clock frequency	62,5 kHz ÷ 4 MHz

Note: Error and/or parity bits should be determined during order

## Sine wave 1 Vpp signals

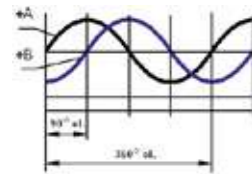

Complementary signals are not shown

# AK58M

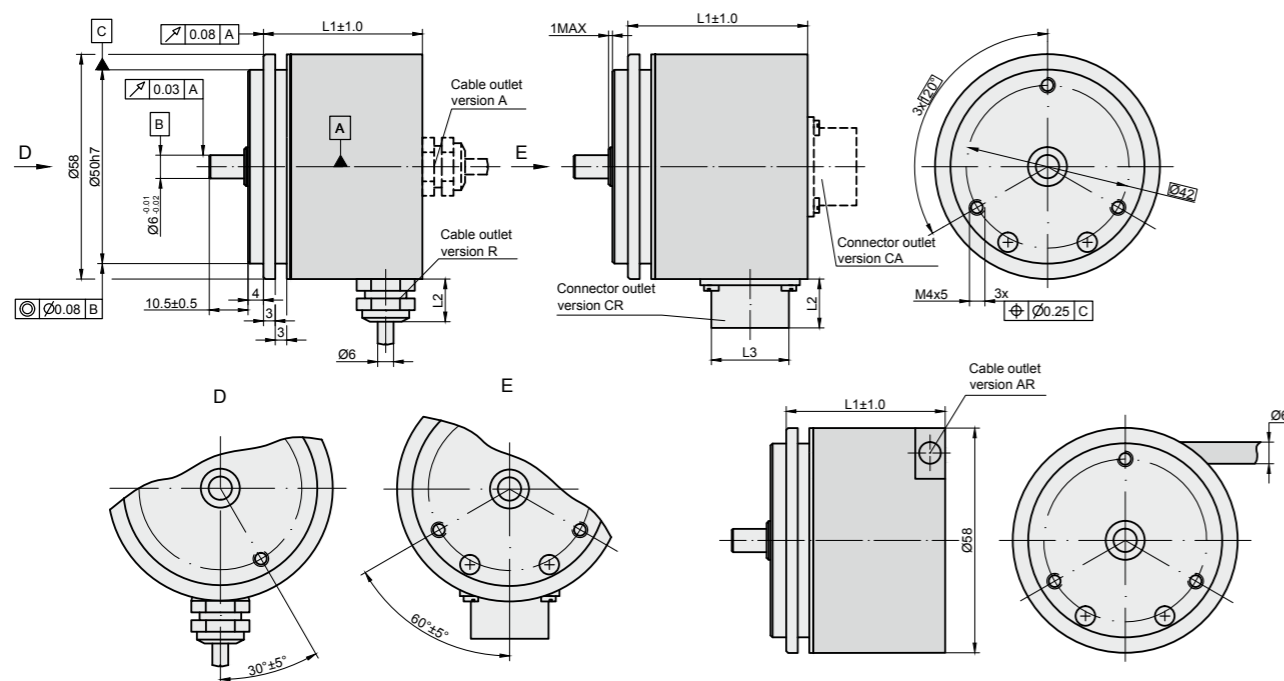

	Connector type / cable outlet	ONC axial	PC10 axial	C12, C9 axial	ONC radial	PC10 radial	C12, C9 radial	Cable axial (ver. A)	Cable radial (ver. R)	Cable axial-radial (ver. AR)
Singleturn	L1	41 mm	41 mm	41 mm	63 mm	55 mm	58 mm	41 mm	41 mm	43 mm
Multiturn	L1	62 mm	62 mm	62 mm	63 mm	55 mm	58 mm	62 mm	53 mm	55
Singleturn/multiturn	L2	16 mm	9 mm	22 mm	16 mm	9 mm	22 mm	12 mm	12 mm	-
Singleturn/multiturn	L3	M24	M14	M23	M24	M14	M23	-	-	-

# AK58B

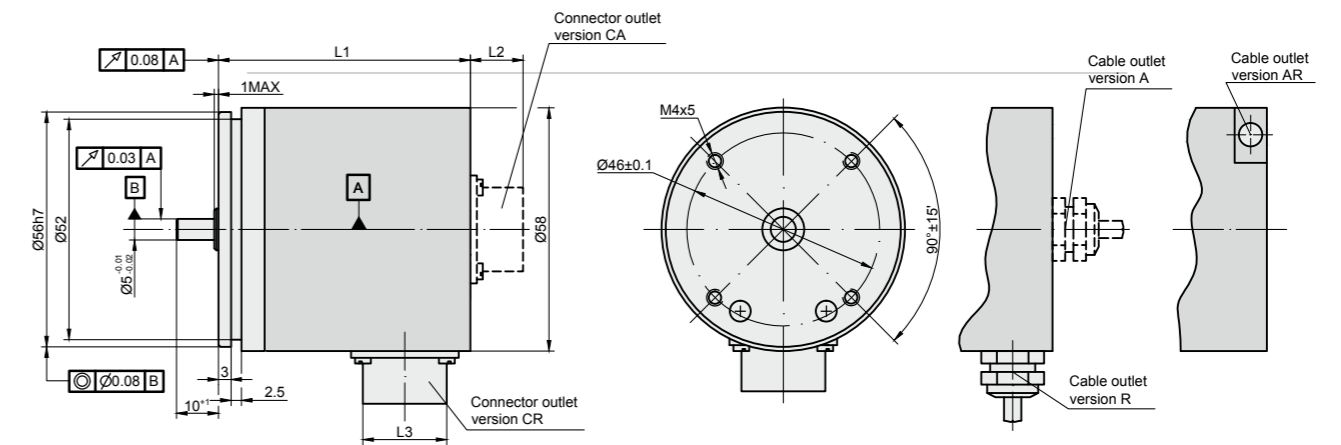

	Connector type / cable outlet	ONC axial	PC10 axial	C12, C9 axial	ONC radial	PC10 radial	C12, C9 radial	Cable axial (ver. A)	Cable radial (ver. R)	Cable axial-radial (ver. AR)
Singleturn	L1	44.5 mm	44.5 mm	44.5 mm	66.5 mm	58.5 mm	61.5 mm	44.5 mm	47.5 mm	46.5 mm
Multiturn	L3	65.5 mm	65.5 mm	65.5 mm	66.5 mm	58.5 mm	61.5 mm	65.5 mm	56.5 mm	58.6
Singleturn/multiturn	L2	16 mm	9 mm	22 mm	16 mm	9 mm	22 mm	12 mm	12 mm	-
Singleturn/multiturn	L3	M24	M14	M23	M24	M14	M23	-	-	-

# AK58C

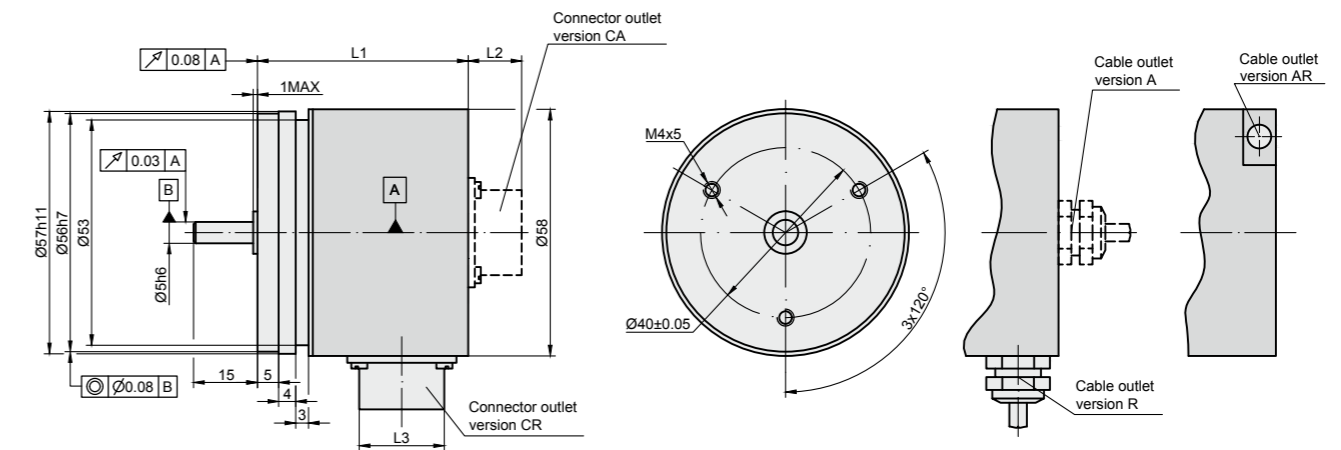

	Connector type / cable outlet	ONC axial	PC10 axial	C12, C9 axial	ONC radial	PC10 radial	C12, C9 radial	Cable axial (ver. A)	Cable radial (ver. R)	Cable axial-radial (ver. AR)
Singleturn	L1	47 mm	47 mm	47 mm	69 mm	61 mm	64 mm	47 mm	50 mm	49 mm
Multiturn	L3	68 mm	68 mm	68 mm	69 mm	61 mm	64 mm	68 mm	59 mm	61
Singleturn/multiturn	L2	16 mm	9 mm	22 mm	16 mm	9 mm	22 mm	12 mm	12 mm	-
Singleturn/multiturn	L3	M24	M14	M23	M24	M14	M23	-	-	-



# AK58C2

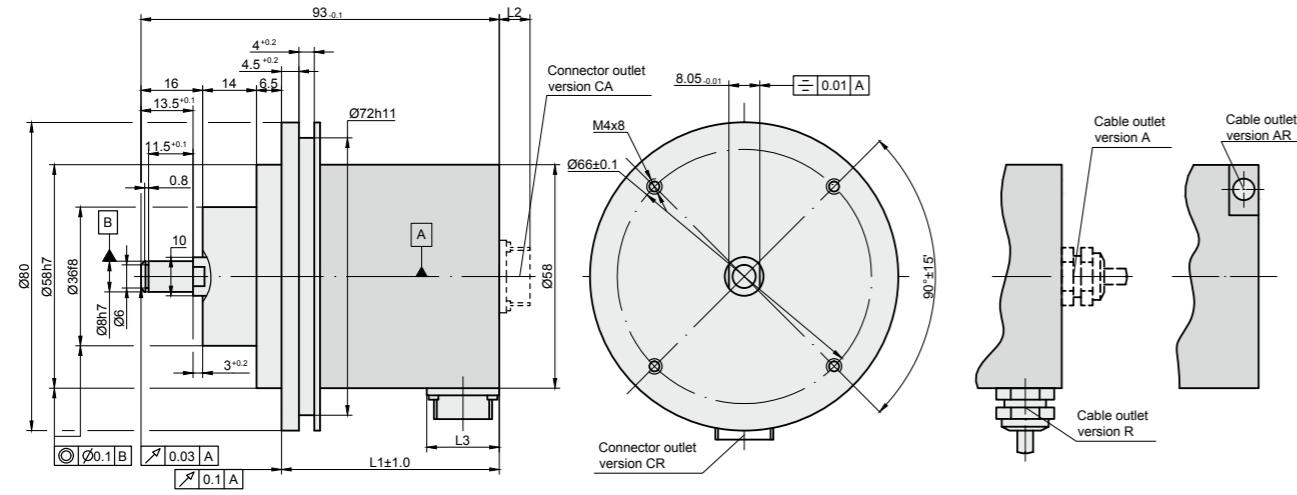

	Connector type / cable outlet	ONC axial	PC10 axial	C12, C9 axial	ONC radial	PC10 radial	C12, C9 radial	Cable axial (ver. A)	Cable radial (ver. R)	Cable axial-radial (ver. AR)
Singleturn	L1	44.5 mm	44.5 mm	44.5 mm	no	58.5 mm	61.5 mm	44.5 mm	47.5 mm	46.5 mm
Multiturn	L3	65.5 mm	65.5 mm	65.5 mm	no	58.5 mm	61.5 mm	65.5 mm	56.5 mm	58.5 mm
Singleturn/multiturn	L2	16 mm	9 mm	22 mm	16 mm	9 mm	22 mm	12 mm	12 mm	-
Singleturn/multiturn	L3	M24	M14	M23	M24	M14	M23	-	-	-

# AK58C3

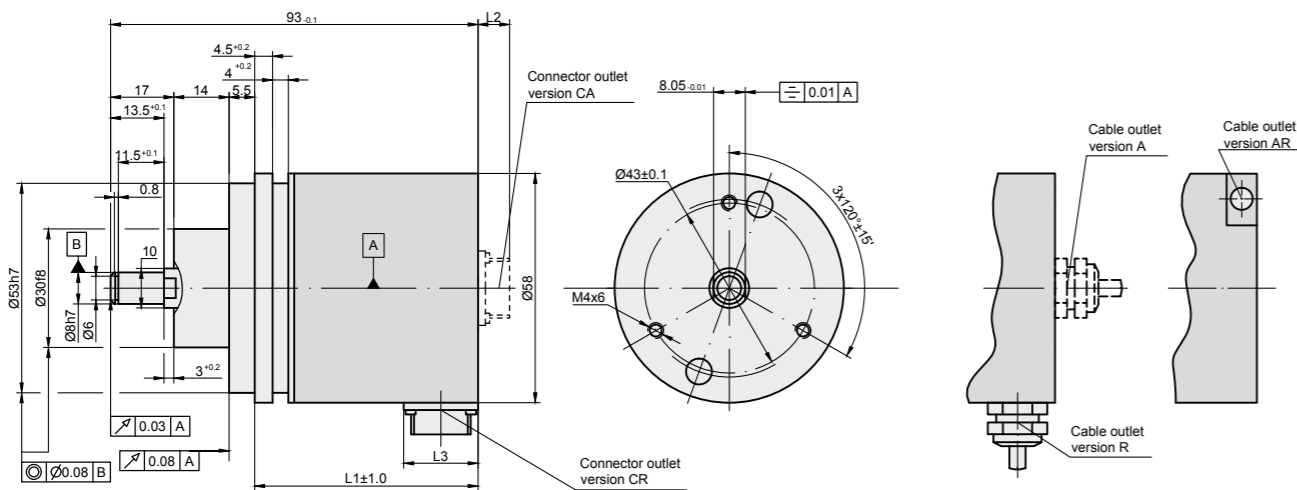

	Connector type / cable outlet	ONC axial	PC10 axial	C12, C9 axial	ONC radial	PC10 radial	C12, C9 radial	Cable axial (ver. A)	Cable radial (ver. R)	Cable axial-radial (ver. AR)
Singleturn	L1	44.5 mm	44.5 mm	44.5 mm	no	58.5 mm	61.5 mm	44.5 mm	47.5 mm	46.5 mm
Multiturn	L3	65.5 mm	65.5 mm	65.5 mm	no	58.5 mm	61.5 mm	65.5 mm	56.5 mm	58.5 mm
Singleturn/multiturn	L2	16 mm	9 mm	22 mm	16 mm	9 mm	22 mm	12 mm	12 mm	-
Singleturn/multiturn	L3	M24	M14	M23	M24	M14	M23	-	-	-

# AK58D

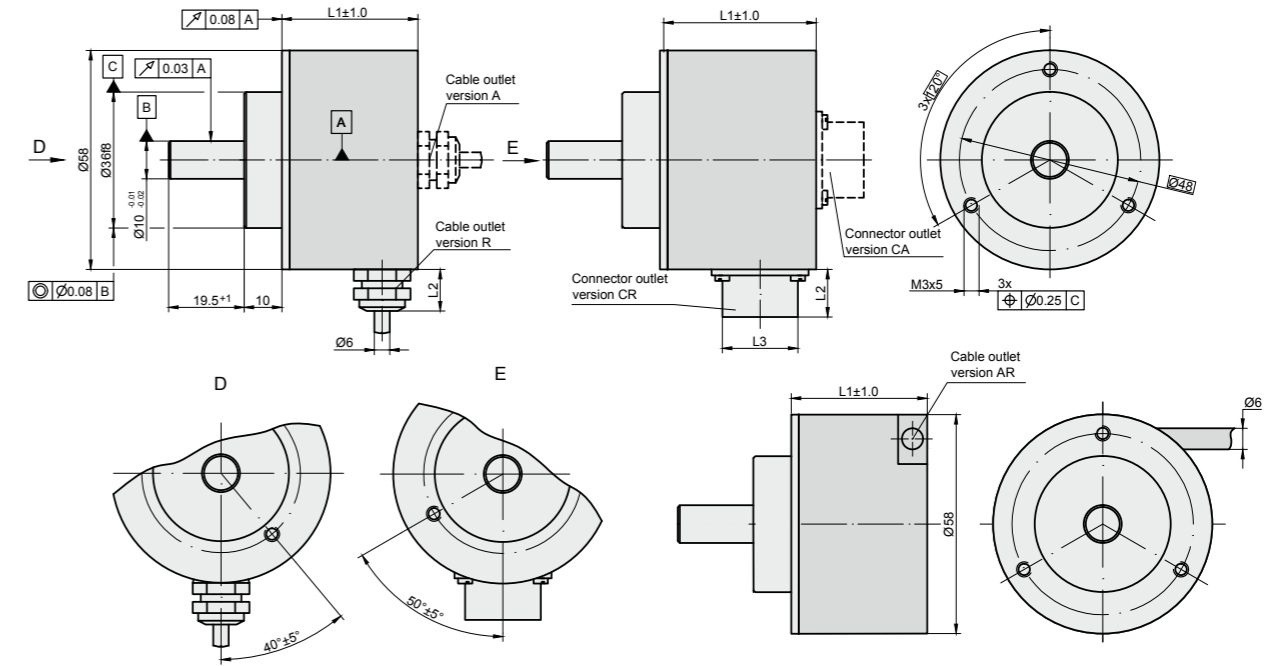

	Connector type / cable outlet	ONC axial	PC10 axial	C12, C9 axial	ONC radial	PC10 radial	C12, C9 radial	Cable axial (ver. A)	Cable radial (ver. R)	Cable axial-radial (ver. AR)
Singleturn	L1	37.5 mm	37.5 mm	37.5 mm	no	51.5 mm	54.5 mm	37.5 mm	40.5 mm	39.5 mm
Multiturn	L3	58.5 mm	58.5 mm	58.5 mm	no	51.5 mm	54.5 mm	58.5 mm	49.5 mm	51.5 mm
Singleturn/multiturn	L2	16 mm	9 mm	22 mm	16 mm	9 mm	22 mm	12 mm	12 mm	-
Singleturn/multiturn	L3	M24	M14	M23	M24	M14	M23	-	-	-

## ORDER FORM

AK58 X1 - X2 - X3 - X4/X5 - X6 - X7 - X8 - X9/X10

Type (X1):	Version (X2):	Output signal interface (X3):	Singleturn Number* (X4):	Multiturn Number* (X5):	Code (X6):	Incremental Signals (X7):	Supply Voltage (X8):	Cable length and outlet or flange socket on case outlet (X9):	Connector (X10):
<b>M</b> - AK58M <b>B</b> - AK58B <b>C</b> - AK58C <b>C2</b> - AK58C2 <b>C3</b> - AK58C3 <b>D</b> - AK58D	<b>ST</b> - singleturn <b>MT</b> - multiturn	<b>S</b> - SSI <b>B</b> - BiSS C	<b>B9</b> - 9 <b>B10</b> - 10 <b>B11</b> - 11 <b>B12</b> - 12 ... <b>B20</b> - 21	<b>M0</b> - 0 (for single turn version) <b>M9</b> - 9 <b>M10</b> - 10 <b>M11</b> - 11 ... <b>M40</b> - 40	<b>B</b> - Binary <b>G</b> - Grey	<b>V</b> - 1Vpp* <b>N</b> - no incremental signal *only for singleturn version	<b>05V</b> - +5V <b>30V</b> - +(10 to 30V)	<b>A01</b> - 1m (A-axial cable) ... <b>R01</b> - 1m (R-radial cable) ... <b>AR01</b> - 1m (AR-universal cable outlet) ... <b>CA</b> - flange socket axial <b>CR</b> - flange socket radial	<b>W</b> - without connector <b>D9</b> - flat, 9 pins <b>C9</b> - round, 9 pins <b>C12</b> - round, 12 pins <b>RS10</b> - round, 10 pins <b>ONC</b> - round, 10 pins
ORDER EXAMPLES: 1) AK58M-ST-S-B9/M0-B-N-05V-AR01/W 2) AK58D-MT-B-B20/M12-G-N-05V-AR01/W									

# PHOTOELECTRIC ROTARY ENCODER

# AK58HE1

-  Absolute Encoder
-  SSI protocol
-  High Resolutions
-  Multiturn Encoder
-  BiSS protocol
-  Hollow Shaft



AK58HE1 is an absolute rotary encoder that comes in blind or through hollow shaft mechanical options. It has up to 40 bit multiturn resolution with SSI interface or up to 24 bit resolution using BiSS C output.

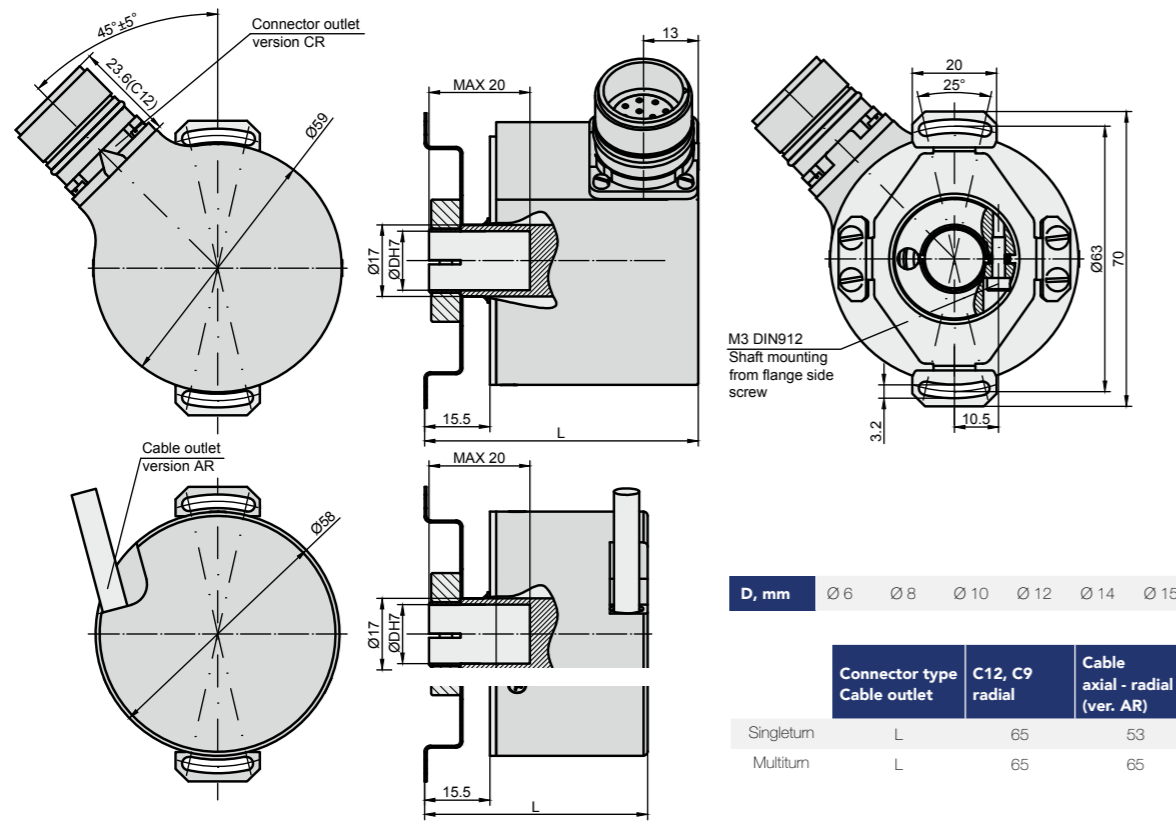

## MECHANICAL DATA

Maximum shaft speed	12000 rpm	Operating temperature	-20...+80 °C
Permissible motion of shaft:	±0.03 mm	- singleturn	-20...+80 °C
	±0.05 mm	- multiturn	-10...+70 °C
Starting torque at 20°C	≤ 0.002 Nm	Storage temperature	-30...+90 °C
Rotor moment of inertia	< 2 gcm <sup>2</sup>	- singleturn	-20...+80 °C
		- multiturn	-20...+80 °C
Protection (IEC 529)	IP64	Maximum humidity (non-condensing)	98 %
Maximum weight without cable	0.35 kg	Permissible vibration (55 to 2000 Hz)	≤ 100 m/s <sup>2</sup>
		Permissible shock (5 ms)	≤ 1000 m/s <sup>2</sup>

## ACCESSORIES

CONNECTORS FOR CABLE	B12	C9	C12	D9	RS10	ONC
	12-pin round connector	9-pin round connector	12-pin round connector	9-pin flat connector	10-pin round connector	10-pin round connector
DIGITAL READOUT DEVICES	CS3000		CS5500			
EXTERNAL INTERPOLATOR	NK					

## ELECTRICAL DATA

Resolution:		Supply voltage	+5V ± 5%; +(10...30)V
Singleturn version:		Light source	LED
- with interface BiSS C	9... 21 bit	Maximum operating frequency:	
- with interface SSI	9... 21 bit	- with interface BiSS C	10 MHz
Multiturn version:		- with interface SSI	4 MHz
- single turn resolution with BiSS C	9... 21 bit	Cable length (standard)	1 m
- multiturn resolution with BiSS C	12/16/20/24 bit	Standard cable length	1 m, without connector
- single turn resolution with SSI	9... 21 bit	Maximum cable length	25 m
- multiturn resolution with SSI	9... 40 bit		
Output code	Gray, binary		
Data interface	SSI, BiSS C		
Accuracy	± 30 arc sec		

### BiSS C serial interface

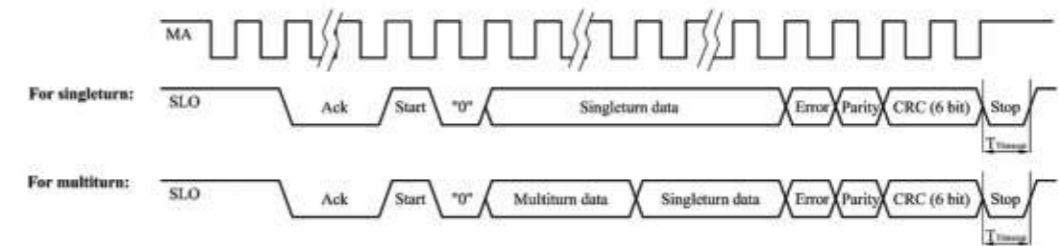

### SSI serial interface

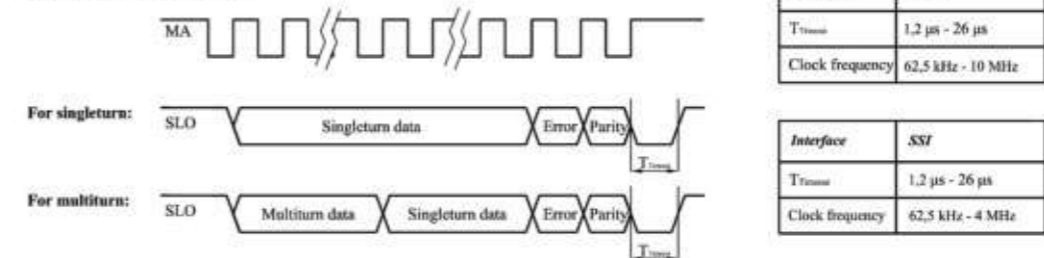

Note:

- Error and parity bits should be determined during order

## MOUNTING REQUIREMENTS

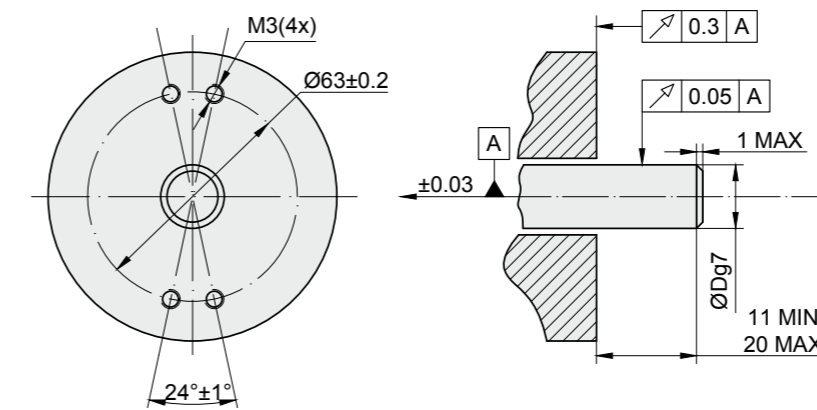

## ORDER FORM

AK58HE1 - X1 - X2 - X3 - X4/X5 - X6 - X7/X8

Mechanical Option (X1):	Version (X2):	Output signal Interface (serial) (X3):	Singleturn bit number* (X4):	Multiturn bit number* (X5):	Code (X6):	Cable outlet and length or connector outlet (X7):	Connector (X8):
1 - through hollow shaft 2 - blind hollow shaft	ST - singleturn MT - multiturn	S - SSI B - BiSS C	B9 - 9 B10 - 10 B11 - 11 B12 - 12 ... B21 - 21	M0 - 0 (for single turn version) M9 - 9 M10 - 10 M11 - 11 ... M40 - 40	B - Binary G - Grey	AR 01 - 1m (AR-universal cable outlet) AR 02 - 2m (AR-universal cable outlet) ... CR - connector radial	W - without connector D9 - flat, 9 pins C9 - round, 9 pins C12 - round, 12 pins RS10 - round, 10 pins ONC - round, 10 pins

ORDER EXAMPLES: 1) AK58HE1-1-MT-B-B20/M12-G-AR01/C12  
2) AK58HE1-2-ST-S-B12/M0-B-AR03/W

PHOTOELECTRIC ROTARY ENCODER

# AP58



The AP58 series is a set of programmable photoelectric rotary encoders that consists of AP58M, AP58B, AP58C, AP58C2, AP58C3, AP58D, AP58HE1 depending on required mounting parameters. Through the programming tool that constitutes of a USB cable and Windows compatible software, the user can set a desired pulse

number per revolution from 1 to 65.536. Software is supplied free of charge and can be found on the official website of Precizika Metrology. It can be installed on any PC running a Windows operating system (Windows XP or later).

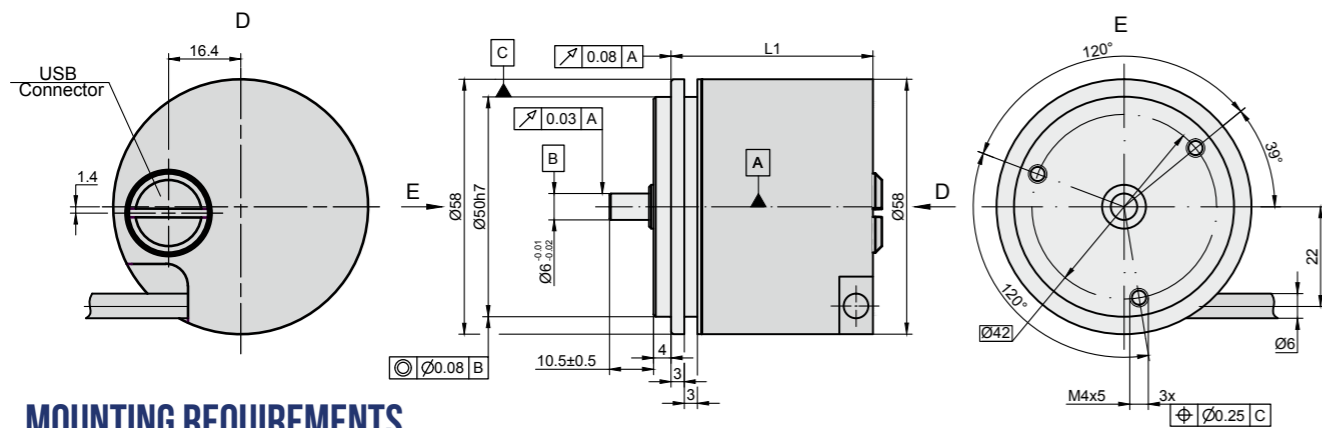

## MOUNTING REQUIREMENTS

ENCODER MODIFICATION	L1	OTHER MODIFICATIONS
AP58M	41 mm	See A58 series data sheet
AP58B	45,5 mm	See A58 series data sheet
AP58C	47 mm	See A58 series data sheet
AP58C2	45,5 mm	See A58 series data sheet
AP58C3	45,5 mm	See A58 series data sheet
AP58D	37,5 mm	See A58 series data sheet

## MECHANICAL DATA

Pulse number per shaft revolution	from 1 to 65536	Protection (IEC 529)	IP64
Maximum shaft speed:	12000 rpm	Maximum weight without cable	0.25 kg
Maximum shaft load:	10 N (40 N for AP58C2, AP58C3, AP58D)	Operating temperature	-10...+70 °C
- axial		Storage temperature	-30...+80 °C
- radial (at shaft end)	20 N (60 N for AP58C2, AP58C3, AP58D)	Maximum humidity (non-condensing)	98 %
Accuracy	± 60 arc. sec	Permissible vibration (55 to 2000 Hz)	≤ 100 m/s <sup>2</sup>
Starting torque at 20°C	≤ 0.01 Nm	Permissible shock (11 ms)	≤ 1000 m/s <sup>2</sup>
Rotor moment of inertia	< 15 gcm <sup>2</sup>		

## ACCESSORIES

CONNECTORS FOR CABLE	B12 12-pin round connector	C12 12-pin round connector	D9 9-pin flat connector	D15 15-pin flat connector	RS10 10-pin round connector	ONC 10-pin round connector
COUPLING	SC30					

## ELECTRICAL DATA

VERSION	AP58-F TTL; HTL
Power supply	+5 V ± 5 %; +(10 to 30) V
- Max. supply current (without load)	120 mA
Light source	LED
Incremental signals	Differential square-wave U1/U1 and U2/U2. Signal levels at 20 mA load current: - low (logic "0") < 0.5 V at U <sub>p</sub> =+5 V - low (logic "0") < 1.5 V at U <sub>p</sub> =10 to 30 V - high (logic "1") > 2.4 V at U <sub>p</sub> =+5 V - high (logic "1") > (U <sub>p</sub> -2) V at U <sub>p</sub> =10 to 30 V
Reference signal	One differential square-wave U0/U0 per revolution.
- width	T/4 or T/2
- position	any
Maximum operating frequency	< 2 MHz
Direction of signals	U2 lags U1 for clockwise rotation (viewed from shaft side)
Maximum rise and fall time	< 0.5 μs
Standard cable length	1m, without connector
Maximum cable length	25m
Output signals	a=0.25T±0.125T

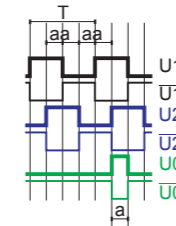

## MODIFICATION AP58HE1

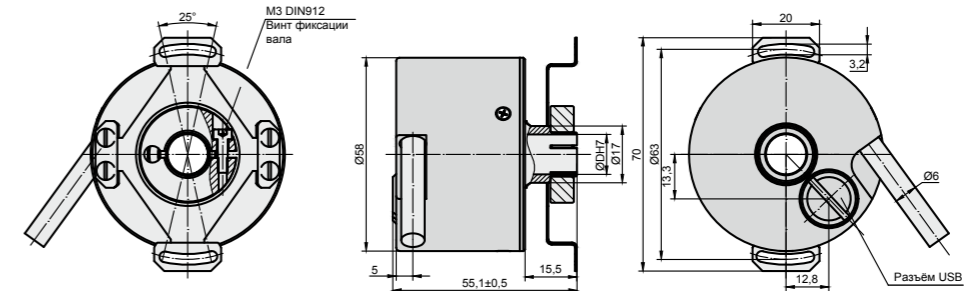

D, mm Ø 6 Ø 8 Ø 10 Ø 12 Ø 14 Ø 15

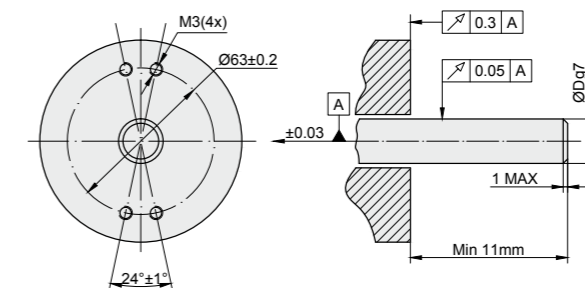

## ORDER FORM

AP58X1 - X2 - X3 - X4/X5

Modification (X1):	Shaft hole diameter* (X2):	Supply voltage (X3):	Cable length (X4):	Connector type (X5):
M - AP58M B - AP58B C - AP58C C2 - AP58C2 C3 - AP58C3 D - AP58D HE1 - AP58HE1	6, 8, 10, 12, 14, 15 - diameter mm* *only for AP58HE1 version	05V - +5V 30V - +(10 to 30) V* *only for AP58 with HTL output	AR01 - 1m AR02 - 2m AR03 - 3m ...	W - without connector D9 - flat, 9 pin C12 - round, 12 pin D15 - flat, 15 pins ONC - round, 10 pins RS10 - round, 10 pins B12 - round, 12 pins

ORDER EXAMPLES: 1) AP58M-05V-AR01/B12;  
2) AP58E1-6-30V-AR03/W  
Default manufacturer parameter set: pulse number per revolution - 1000; reference signal width - 1/4T

PHOTOELECTRIC ROTARY ENCODER

# A58HE



High Resolutions



Analog output signals



Hollow Shaft



Photoelectric rotary encoder A58HE can produce up to 108.000 output pulses per revolution and has different signal options: 11 µApp, 1Vpp, TTL or HTL.

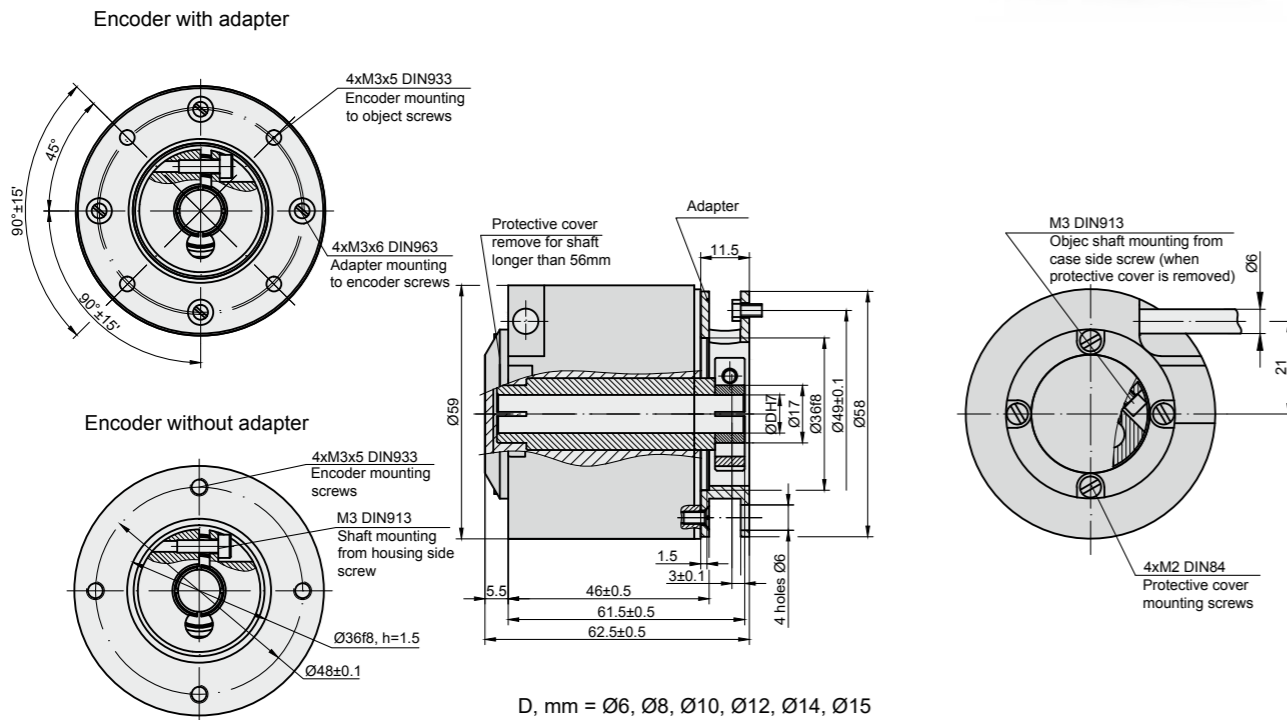

## MECHANICAL DATA

Line number on disc (z)	100; 250; 500; 600; 800; 1000; 1024; 1125; 1250; 1500; 2000; 2048; 2500; 3000; 3600; 4000; 5000; 9000; 10800	Starting torque at 20°C	≤ 0.025 Nm
Pulse number per shaft revolution for A58-F	Z x k, where k=1,2,3,4,5,8,10 (k - interpolation factor)	Rotor moment of inertia	< 1.5x10 <sup>-4</sup> kgm <sup>2</sup>
Maximum shaft speed	10000 rpm	Protection (housing) ( IEC 529)	IP64
Permissible motion of shaft:	±0.03 mm - axial 0.05 mm - radial (at shaft end)	Protection (shaft side) ( IEC 529)	IP64
Accuracy (T <sub>p</sub> -period of lines on disc in arc. sec)	±0.1T <sub>p</sub> arc. sec - on option for z < 5000 ±0.05T <sub>p</sub> arc. sec - on option for z > 5000 ±12.0 arc. sec	Maximum weight without cable	0.35 kg
		Operating temperature	0...+70 °C
		Storage temperature	-30...+80 °C
		Maximum humidity (non-condensing)	98 %
		Permissible vibration (55 to 2000 Hz)	≤ 100 m/s <sup>2</sup>
		Permissible shock (11 ms)	≤ 300 m/s <sup>2</sup>

## ACCESSORIES

CONNECTORS FOR CABLE	B12 12-pin round connector	C9 9-pin round connector	C12 12-pin round connector	D9 9-pin flat connector	D15 15-pin flat connector	RS10 10-pin round connector	ONC 10-pin round connector
DIGITAL READOUT DEVICES	CS3000			CS5500			
EXTERNAL INTERPOLATOR	NK						

## ELECTRICAL DATA

Version	A58HE-A ~ 11 µApp	A58HE-AV ~ 1 Vpp	A58HE-F □□ TTL; □□ HTL
Supply voltage (U <sub>p</sub> )	+5 V ± 5%	+5 V ± 5%	+5 V ± 5%; +(10 to 30) V
Max. supply current (without load)	80 mA	120 mA	120 mA
Light source	LED	LED	LED
Incremental signals	Two sinusoidal I <sub>1</sub> and I <sub>2</sub> Amplitude at 1 kΩ load: - I <sub>1</sub> = 7-16 µA - I <sub>2</sub> = 7-16 µA	Differential sine +A/-A and +B/-B Amplitude at 120 Ω load: - A = 0.6-1.2 V - B = 0.6-1.2 V	Differential square-wave U1/̄U1 and U2/̄U2. Signal levels at 20 mA load current: - low (logic "0") ≤ 0.5 V at U <sub>p</sub> =+5 V - low (logic "0") ≤ 1.5 V at U <sub>p</sub> =10 to 30 V - high (logic "1") ≥ 2.4 V at U <sub>p</sub> =+5 V - high (logic "1") ≥ (U <sub>p</sub> -2) V at U <sub>p</sub> =10 to 30 V
Reference signal	One quasi-triangular I <sub>0</sub> peak per revolution. Signal magnitude at 1 kΩ load: - I <sub>0</sub> = 2-8 µA (usable component)	One quasi-triangular +R and its complementary -R per revolution. Signals magnitude at 120Ω load - R = 0.2-0.8 V (usable component)	One differential square-wave U0/̄U0 per revolution. Signal levels at 20 mA load current: - low (logic "0") < 0.5 V at U <sub>p</sub> =+5 V - low (logic "0") < 1.5 V at U <sub>p</sub> =10 to 30 V - high (logic "1") > 2.4 V at U <sub>p</sub> =+5 V - high (logic "1") > (U <sub>p</sub> -2) V at U <sub>p</sub> =10 to 30 V
Maximum operating frequency	(-3 dB) ≥ 160 kHz	(-3 dB) ≥ 180 kHz	(160 x k) kHz, k-interpolation factor
Direction of signals	I <sub>2</sub> lags I <sub>1</sub> for clockwise rotation	+B lags +A for clockwise rotation	U2 lags U1 with clockwise rotation
Maximum rise and fall time	-	-	< 0.5 µs
Standard cable length	1 m, without connector	1 m, without connector	1 m, without connector
Maximum cable length	5 m	25 m	25 m
Output signals			

Note:

- Maximum working rotation speed (with proper encoder counting) is limited by maximum operating frequency and maximum mechanical rotation speed.
- If cable extension is used, power supply conductor cross-section should not be smaller than 0.5 mm<sup>2</sup>

## MOUNTING REQUIREMENTS

L, mm	11 min for one side fixation
	56 min for both side fixation
	56 max for version with protective cover
	11 min for version without protective cover

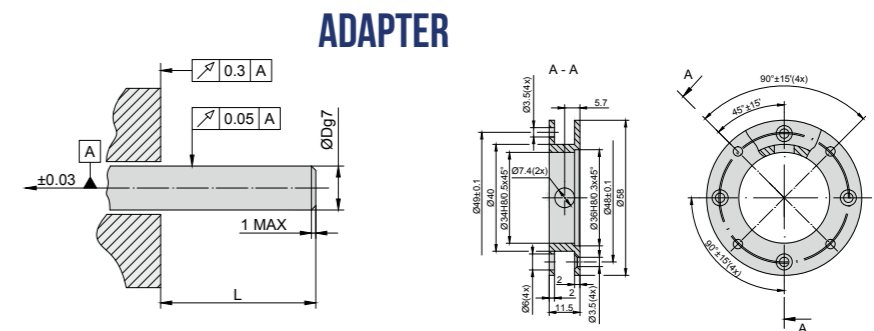

## ORDER FORM

A58HE	- X1	- X2/X3	- X4	- X5	- X6/X7	- X8	
Output signal version (X1):	Pulse number per Revolution (X2):	Optional line number on disc (z) (X3):	Shaft hole Diameter (X4):	Supply Voltage (X5):	Cable length (X6):	Connector type (X7):	Adapter (X8):
A AV F	100 ... 108000*	100 ... 10800	6, 8, 10, 12, 14, 15 - mm	05V - +5V 30V - +(10 to 30) V*	AR01 - 1m AR02 - 2m AR03 - 3m ...	W - without connector B12 - round, 12 pins C9 - round, 9 pins C12 - round, 12 pins D9 - flat, 9 pins D15 - flat, 15 pins RS10 - round, 10 pins ONC - round, 10 pins	W - without adapter S - with adapter
*only F signal version for >18000 pulses							
ORDER EXAMPLES: 1) A58HE-AV-1024-6-05V-AR01/W-W 2) A58HE-F-4000-8-30V-AR06/C12-S 3) A58HE-F-4000/500-8-30V-AR06/C12-S							



# PHOTOELECTRIC ROTARY ENCODER

# A58HME



High Resolutions

Analog output signals

Hollow Shaft



Photoelectric encoder A58HME can produce up to 108.000 output pulses per revolution and is a very similar encoder to the A58HE

series. The main difference between the two is that A58HME has a 6-15 mm diameter blind hollow shaft.

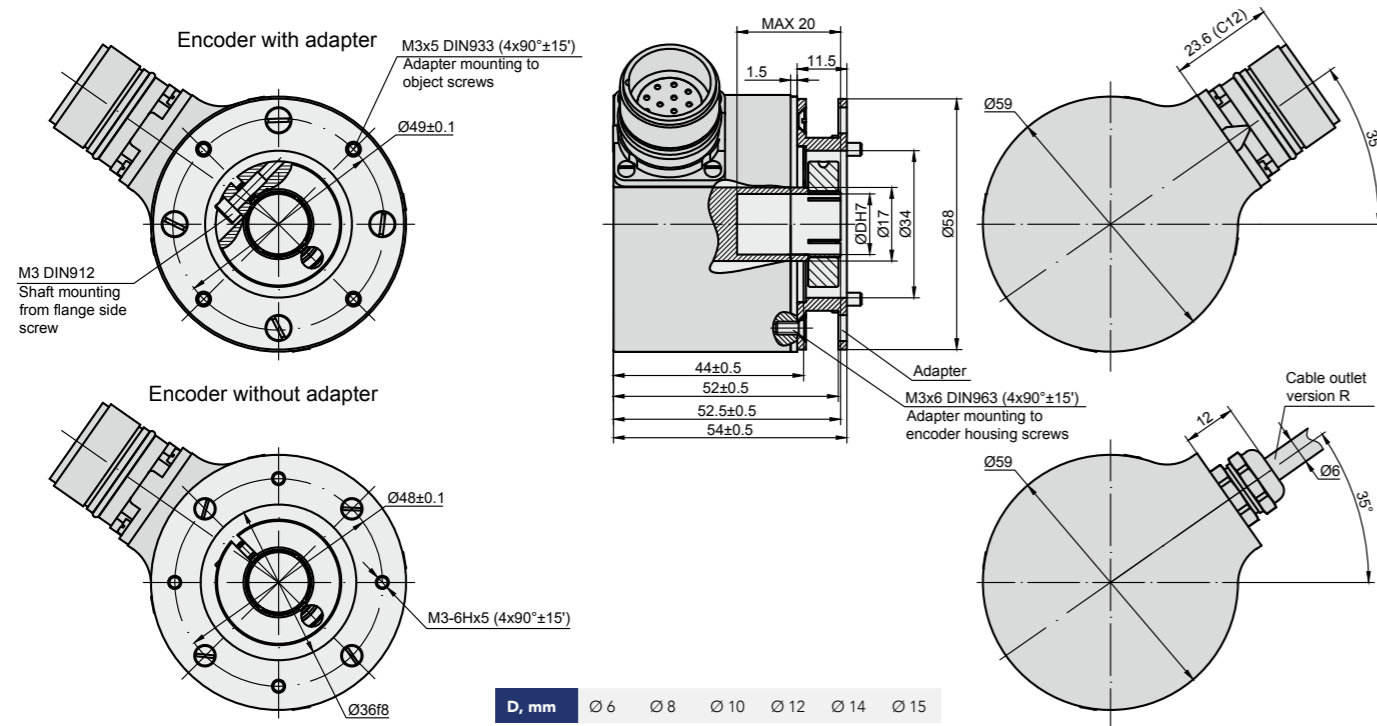

## MECHANICAL DATA

Line number on disc (z)	100; 250; 500; 600 800; 1000; 1024; 1125; 1250; 1500; 2000; 2048; 2500; 3000; 3600; 4000; 5000; 9000; 10800	Starting torque at 20°C	≤ 0.025 Nm
Number of output pulses per revolution for A58HME-F	Z x k, where k=1,2,3,4,5,8,10 (k - interpolation factor)	Rotor moment of inertia	< 1.5x10 <sup>-4</sup> kgm <sup>2</sup>
Maximum shaft speed	10000 rpm	Protection (housing) ( IEC 529)	IP64
Permissible motion of shaft: - axial - radial (at shaft end)	±0.03 mm 0.05 mm	Protection (shaft side) ( IEC 529)	IP64
Accuracy (T <sub>1</sub> -period of lines on disc in arc. sec) - on option for z < 5000 - on option for z > 5000	±0.1T <sub>1</sub> arc. sec ±0.05T <sub>1</sub> arc. sec ±12.0 arc. sec	Maximum weight without cable	0.35 kg
		Operating temperature	0...+70 °C
		Storage temperature	-30...+80 °C
		Maximum humidity (non-condensing)	98 %
		Permissible vibration (55 to 2000 Hz)	≤ 100 m/s <sup>2</sup>
		Permissible shock (11 ms)	≤ 300 m/s <sup>2</sup>

## ACCESSORIES

<b>CONNECTORS FOR CABLE</b>	C12 12-pin flange socket	C9 9-pin flange socket
<b>DIGITAL READOUT DEVICES</b>	CS3000	CS5500
<b>EXTERNAL INTERPOLATOR</b>		NK

## ELECTRICAL DATA

Version	A58HME-A ~ 11 µApp	A58HME-AV ~ 1 Vpp	A58HME-F □ TTL; □ HTL
Supply voltage (U <sub>p</sub> )	+5 V ± 5%	+5 V ± 5%	+5 V ± 5%; +(10 to 30) V
Max. supply current (without load)	80 mA	120 mA	120 mA
Light source	LED	LED	LED
Incremental signals	Two sinusoidal I <sub>1</sub> and I <sub>2</sub> Amplitude at 1 kΩ load: - I <sub>1</sub> = 7-16 µA - I <sub>2</sub> = 7-16 µA	Differential sine +A/-A and +B/-B Amplitude at 120 Ω load: - A = 0.6-1.2 V - B = 0.6-1.2 V	Differential square-wave U1/Ū1 and U2/Ū2. Signal levels at 20 mA load current: - low (logic "0") ≤ 0.5 V at U <sub>p</sub> =+5 V - low (logic "0") ≤ 1.5 V at U <sub>p</sub> =10 to 30 V - high (logic "1") ≥ 2.4 V at U <sub>p</sub> =+5 V - high (logic "1") ≥ (U <sub>p</sub> -2) V at U <sub>p</sub> =10 to 30 V
Reference signal	One quasi-triangular I <sub>0</sub> peak per revolution. Signal magnitude at 1 kΩ load: - I <sub>0</sub> = 2-8 µA (usable component)	One quasi-triangular +R and its complementary -R per revolution. Signals magnitude at 120Ω load - R = 0.2-0.8 V (usable component)	One differential square-wave U0/Ū0 per revolution. Signal levels at 20 mA load current: - low (logic "0") < 0.5 V at U <sub>p</sub> =+5 V - low (logic "0") < 1.5 V at U <sub>p</sub> =10 to 30 V - high (logic "1") > 2.4 V at U <sub>p</sub> =+5 V - high (logic "1") > (U <sub>p</sub> -2) V at U <sub>p</sub> =10 to 30 V
Maximum operating frequency	(-3 dB) ≥ 160 kHz	(-3 dB) ≥ 180 kHz	(160 x k) kHz, k-interpolation factor
Direction of signals	I <sub>2</sub> lags I <sub>1</sub> for clockwise rotation	+B lags +A for clockwise rotation	U2 lags U1 with clockwise rotation
Maximum rise and fall time	-	-	< 0.5 µs
Standard cable length	1 m, without connector	1 m, without connector	1 m, without connector
Maximum cable length	5 m	25 m	25 m
Output signals			

Note:

- Maximum working rotation speed (with proper encoder counting) is limited by maximum operating frequency and maximum mechanical rotation speed.
- If cable extension is used, power supply conductor cross-section should not be smaller than 0.5 mm<sup>2</sup>.

## MOUNTING REQUIREMENTS

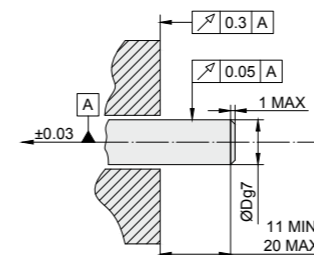

## ADAPTER

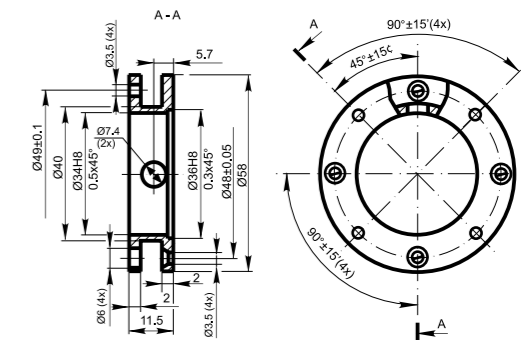

## ORDER FORM

Output signal version (X1):	Pulse number per Revolution (X2):	Optional line number on disc (z) (X3):	Shaft hole Diameter (X4):	Supply Voltage (X5):	Cable length (X6):	Connector type (X7):	Adapter (X8):
A AV F	100 ... 108000*	100 ... 10800	6, 8, 10, 12, 14, 15 - mm	05V - +5V 30V - +(10 to 30) V*	R01 - 1m R02 - 2m R03 - 3m ... CR - flange socket radial	W - without connector C9 - round, 9 pins C12 - round, 12 pins D9 - flat, 9 pins	W - without adapter S - with adapter
ORDER EXAMPLES:				1) A58HME-AV-1024-6-05V-W; 2) A58HME-F-4000-8-30V-S; 3) A58HME-F-4000/500-8-30V-S			

# PHOTOELECTRIC ROTARY ENCODER

# A58HE1



High Resolutions



Analog output signals



Hollow Shaft



Photoelectric incremental hollow shaft encoder A58HE1 has an external flexible coupling and it is the main feature that differs it from other similar encoders. It is able to produce up to 108.000 output pulses per

revolution and has different output signal versions available: 11  $\mu$ App, 1Vpp, TTL or HTL.

## VERSION 1 - THROUGH HOLLOW SHAFT

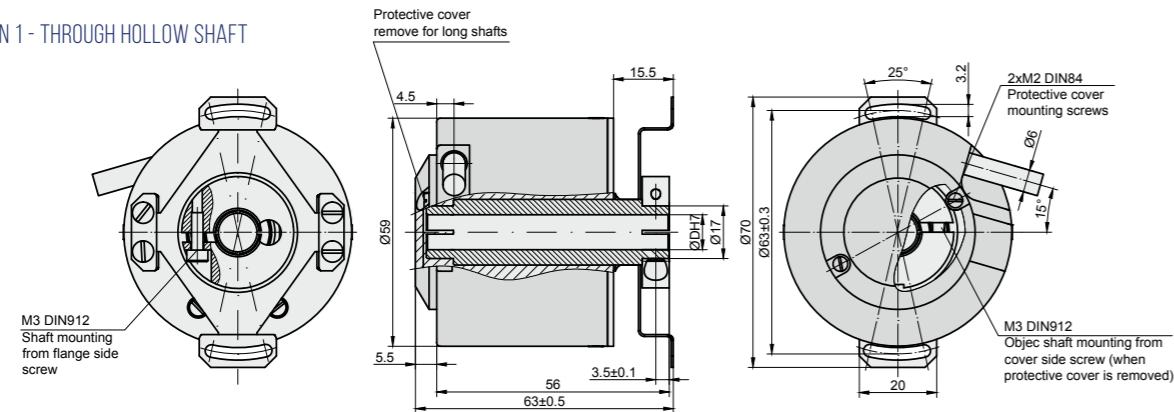

## VERSION 2 - BLIND HOLLOW SHAFT

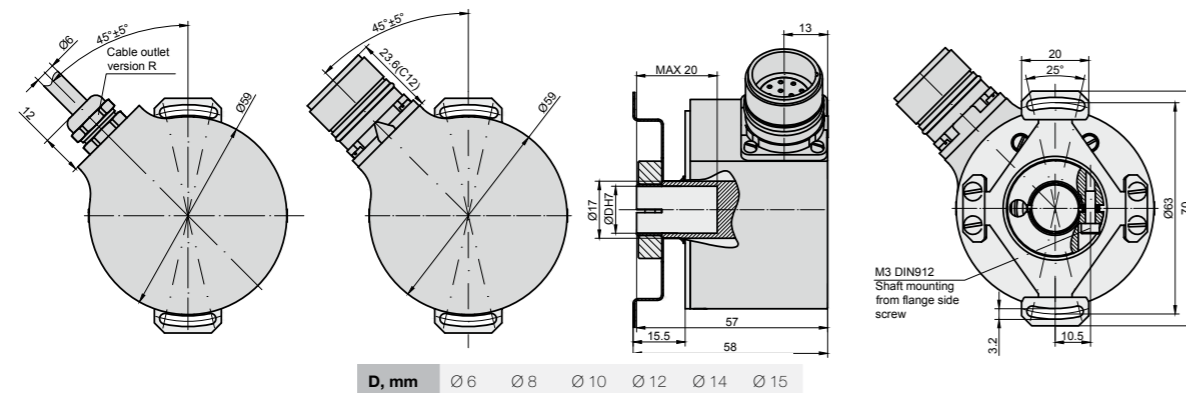

D, mm  $\varnothing 6$   $\varnothing 8$   $\varnothing 10$   $\varnothing 12$   $\varnothing 14$   $\varnothing 15$

## MECHANICAL DATA

Line number on disc (z)	100; 250; 500; 600 800; 1000; 1024; 1125; 1250; 1500; 2000; 2048; 2500; 3000; 3600; 4000; 5000; 9000; 10800	Rotor moment of inertia	$< 1.5 \times 10^{-4} \text{ kgm}^2$
Number of output pulses per revolution for A58HE1-F	Z x k, where k=1,2,3,4,5,8,10 (k - interpolation factor)	Protection (housing) ( IEC 529)	IP64
Maximum shaft speed	10000 rpm	Protection (shaft side) ( IEC 529)	IP64
Permissible motion of shaft: - axial - radial (at shaft end)	$\pm 0.03 \text{ mm}$ $0.05 \text{ mm}$	Maximum weight without cable	0.3 kg
Accuracy ( $T_1$ -period of lines on disc in arc. sec)	$\pm 0.1 T_1$ arc. sec	Operating temperature	$-10 \dots +70 \text{ }^\circ\text{C}$
Starting torque at 20°C	$\leq 0.025 \text{ Nm}$	Storage temperature	$-30 \dots +80 \text{ }^\circ\text{C}$
		Maximum humidity (non-condensing)	98 %
		Permissible vibration (55 to 2000 Hz)	$\leq 100 \text{ m/s}^2$
		Permissible shock (5 ms)	$\leq 1000 \text{ m/s}^2$

## ACCESSORIES

<b>CONNECTORS FOR CABLE</b>	C9, 9-pin round connector	C12, 12-pin round connector	C12, 12-pin flange socket	C9, 9-pin flange socket
<b>DIGITAL READOUT DEVICES</b>	CS3000		CS5500	
<b>EXTERNAL INTERPOLATOR</b>	NK			

## ELECTRICAL DATA

Version	A58HE1-A $\sim 11 \mu\text{App}$	A58HE1-AV $\sim 1 \text{ Vpp}$	A58HE1-F $\square$ TTL; $\square$ HTL
Supply voltage ( $U_p$ )	+5 V $\pm 5\%$	+5 V $\pm 5\%$	+5 V $\pm 5\%$ ; +(10 to 30) V
Max. supply current (without load)	80 mA	120 mA	120 mA
Light source	LED	LED	LED
Incremental signals	Two sinusoidal $I_1$ and $I_2$ Amplitude at 1 k $\Omega$ load: - $I_1 = 7-16 \mu\text{A}$ - $I_2 = 7-16 \mu\text{A}$	Differential sine +A/-A and +B/-B Amplitude at 120 $\Omega$ load: - A = 0.6-1.2 V - B = 0.6-1.2 V	Differential square-wave $U1/\overline{U1}$ and $U2/\overline{U2}$ . Signal levels at 20 mA load current: - low (logic "0") $\leq 0.5 \text{ V}$ at $U_p = +5 \text{ V}$ - low (logic "0") $\leq 1.5 \text{ V}$ at $U_p = 10 \text{ to } 30 \text{ V}$ - high (logic "1") $\geq 2.4 \text{ V}$ at $U_p = +5 \text{ V}$ - high (logic "1") $\geq (U_p - 2) \text{ V}$ at $U_p = 10 \text{ to } 30 \text{ V}$
Reference signal	One quasi-triangular $I_0$ peak per revolution. Signal magnitude at 1 k $\Omega$ load: - $I_0 = 2-8 \mu\text{A}$ (usable component)	One quasi-triangular +R and its complementary -R per revolution. Signals magnitude at 120 $\Omega$ load - R = 0.2-0.8 V (usable component)	One differential square-wave $U0/\overline{U0}$ per revolution. Signal levels at 20 mA load current: - low (logic "0") $< 0.5 \text{ V}$ at $U_p = +5 \text{ V}$ - low (logic "0") $< 1.5 \text{ V}$ at $U_p = 10 \text{ to } 30 \text{ V}$ - high (logic "1") $> 2.4 \text{ V}$ at $U_p = +5 \text{ V}$ - high (logic "1") $> (U_p - 2) \text{ V}$ at $U_p = 10 \text{ to } 30 \text{ V}$
Maximum operating frequency	(-3 dB) $\geq 160 \text{ kHz}$	(-3 dB) $\geq 180 \text{ kHz}$	(160 x k) kHz, k-interpolation factor
Direction of signals	$I_2$ lags $I_1$ for clockwise rotation	+B lags +A for clockwise rotation	$U2$ lags $U1$ with clockwise rotation
Maximum rise and fall time	-	-	$< 0.5 \mu\text{s}$
Standard cable length	1 m, without connector	1 m, without connector	1 m, without connector
Maximum cable length	5 m	25 m	25 m
Output signals			

Note:

- Maximum working rotation speed (with proper encoder counting) is limited by maximum operating frequency and maximum mechanical rotation speed.
- If cable extension is used, power supply conductor cross-section should not be smaller than 0.5 mm<sup>2</sup>.

## MOUNTING REQUIREMENTS

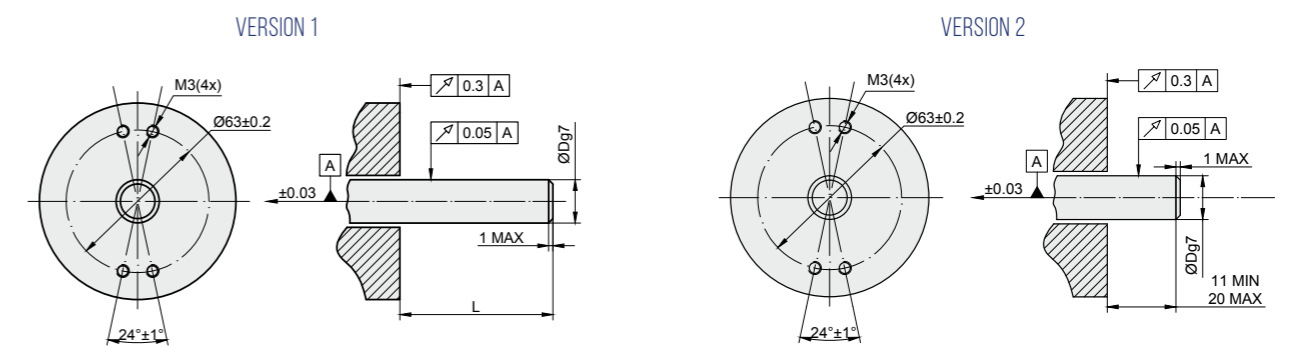

L, mm	11 min for one side fixation
	56 min for both side fixation
	56 max for version with protective cover
	11 min for version without protective cover

## ORDER FORM

Mechanical Version (X1):	Output signal version (X2):	Pulse number per Revolution (X3):	Optional line number on disc (z) (X4):	Shaft hole Diameter (X5):	Supply Voltage (X6):	Cable length (X7):	Connector type (X8):
1 - through hollow shaft 2 - blind hollow shaft	A AV F	100 ... 108000*	100 ... 10800	6, 8, 10, 12, 14, 15 - mm	05V - +5V 30V - +(10 to 30)V*	AR01 - 1m AR02 - 2m AR03 - 3m R01 - 1m ... CR - flange socket radial	W - without connector C9 - round, 9 pins C12 - round, 12 pins D9 - flat, 9 pins

ORDER EXAMPLES: 1) A58HE1-1-AV-5000-8-05V-01/C12;  
2) A58HE1-2-F-10000/2500-10-30V-CR/C12

# PHOTOELECTRIC ROTARY ENCODER

# A102H



Photoelectric rotary encoder A102H contains 5.000 lines on disc in a standard version, but other modifications are possible on request. This wide diameter encoder has the biggest shaft available on our rotary encoders product range.

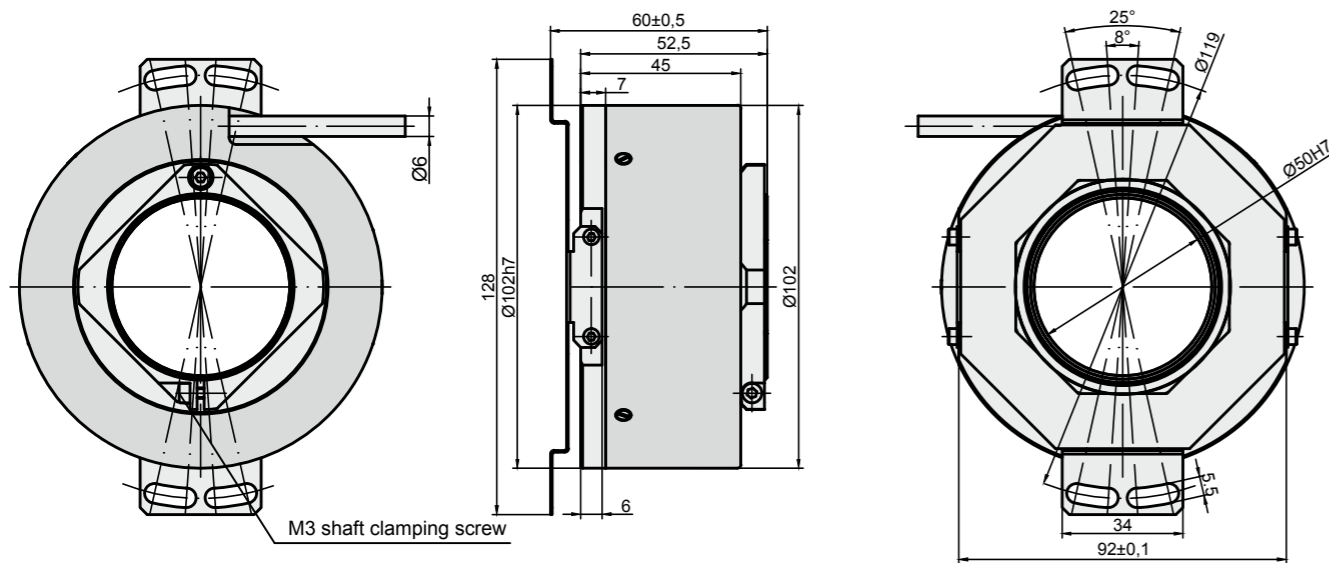

## MECHANICAL DATA

Line number on disc (z)	5000; 9000 (others on request)	Rotor moment of inertia	< 20x10 <sup>-4</sup> kgm <sup>2</sup>
Number of output pulses per revolution for A102H-F	Z x k, where k=1,2,3,4,5,8,10, 20, 25, 50, 100 and others (k - interpolation factor)	Protection (housing) ( IEC 529)	IP64
Maximum shaft speed	8000 rpm	Maximum weight without cable	0.8 kg
Permissible motion of shaft: - axial - radial (at shaft end)	±1.0 mm 0.02 mm	Operating temperature	-20...+70 °C
Accuracy (T <sub>1</sub> -period of lines on disc in arc. sec)	±0.05T <sub>1</sub> arc. sec	Storage temperature	-30...+85 °C
Starting torque at 20°C	≤ 0.01 Nm	Maximum humidity (non-condensing)	98 %
		Permissible vibration (55 to 2000 Hz)	≤ 100 m/s <sup>2</sup>
		Permissible shock (5 ms)	≤ 300 m/s <sup>2</sup>

## ACCESSORIES

CONNECTORS FOR CABLE	C9 9-pin round connector	C12 12-pin round connector	D9 9-pin flat connector
DIGITAL READOUT DEVICES	CS3000		CS5500
EXTERNAL INTERPOLATOR	NK		

## ELECTRICAL DATA

Version	A102H-A ~ 11 µApp	A102H-AV ~ 1 Vpp	A102H-F □ TTL; □ HTL
Supply voltage (U <sub>p</sub> )	+5 V ± 5%	+5 V ± 5%	+5 V ± 5%; +(10 to 30) V
Max. supply current (without load)	100 mA	120 mA	120 mA
Light source	LED	LED	LED
Incremental signals	Two sinusoidal I <sub>1</sub> and I <sub>2</sub> . Amplitude at 1 kΩ load: - I <sub>1</sub> = 7-16 µA - I <sub>2</sub> = 7-16 µA	Differential sine +A/-A and +B/-B. Amplitude at 120 Ω load: - A = 0.6-1.2 V - B = 0.6-1.2 V	Differential square-wave U1/Ū1 and U2/Ū2. Signal levels at 20 mA load current: - low (logic "0") ≤ 0.5 V at U <sub>p</sub> =+5 V - low (logic "0") ≤ 1.5 V at U <sub>p</sub> =10 to 30 V - high (logic "1") ≥ 2.4 V at U <sub>p</sub> =+5 V - high (logic "1") ≥ (U <sub>p</sub> -2) V at U <sub>p</sub> =10 to 30 V
Reference signal	One quasi-triangular I <sub>0</sub> peak per revolution. Signal magnitude at 1 kΩ load: - I <sub>0</sub> = 2-8 µA (usable component)	One quasi-triangular +R and its complementary -R per revolution. Signals magnitude at 120Ω load - R = 0.2-0.8 V (usable component)	One differential square-wave U0/Ū0 per revolution. Signal levels at 20 mA load current: - low (logic "0") < 0.5 V at U <sub>p</sub> =+5 V - low (logic "0") < 1.5 V at U <sub>p</sub> =10 to 30 V - high (logic "1") > 2.4 V at U <sub>p</sub> =+5 V - high (logic "1") > (U <sub>p</sub> -2) V at U <sub>p</sub> =10 to 30 V
Maximum operating frequency	(-3 dB) ≥ 160 kHz	(-3 dB) ≥ 180 kHz	(160-1300 x k) kHz, k-interpolation factor
Direction of signals	I <sub>2</sub> lags I <sub>1</sub> for clockwise rotation	+B lags +A for clockwise rotation	U2 lags U1 with clockwise rotation
Maximum rise and fall time	-	-	< 0.5 µs
Standard cable length	1 m, without connector	1 m, without connector	1 m, without connector
Maximum cable length	5 m	25 m	25 m
Output signals			

Note:

- Maximum working rotation speed (with proper encoder counting) is limited by maximum operating frequency and maximum mechanical rotation speed.
- If cable extension is used, power supply conductor cross-section should not be smaller than 0.5 mm<sup>2</sup>.

## MOUNTING DIMENSIONS

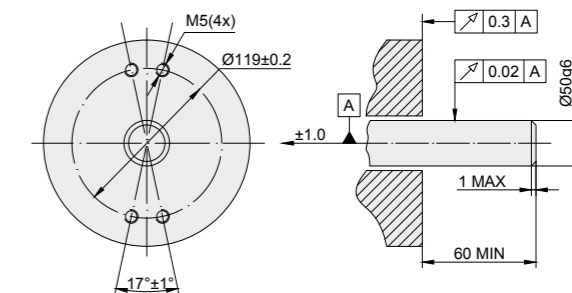

## ORDER FORM

<b>A102H</b> - X1 - X2 - X3/X4			
Output signal version (X1):	Pulse number per Revolution (X2):	Cable length (X3):	Connector type (X4):
A AV F	5000 9000 ... 900000*	AR01 - 1m AR02 - 2m AR03 - 3m ...	W - without connector C9 - round, 9 pins C12 - round, 12 pins D9 - flat, 9 pins
*only F signal version for >5000 pulses			
ORDER EXAMPLES: 1) A102H-AV-500-AR01/C9; 2) A102H-F-10800-AR01/C12			



# MAGNETIC ROTARY ENCODER

# AM



Absolute Encoder



Magnetic Technology



SSI protocol



AM36 and AM58 series' incremental/absolute encoders use magnetic technology and output up to 12 bit resolution through binary

code. These encoders can have different signal modifications: incremental, serial interface, commutation.

## AM36

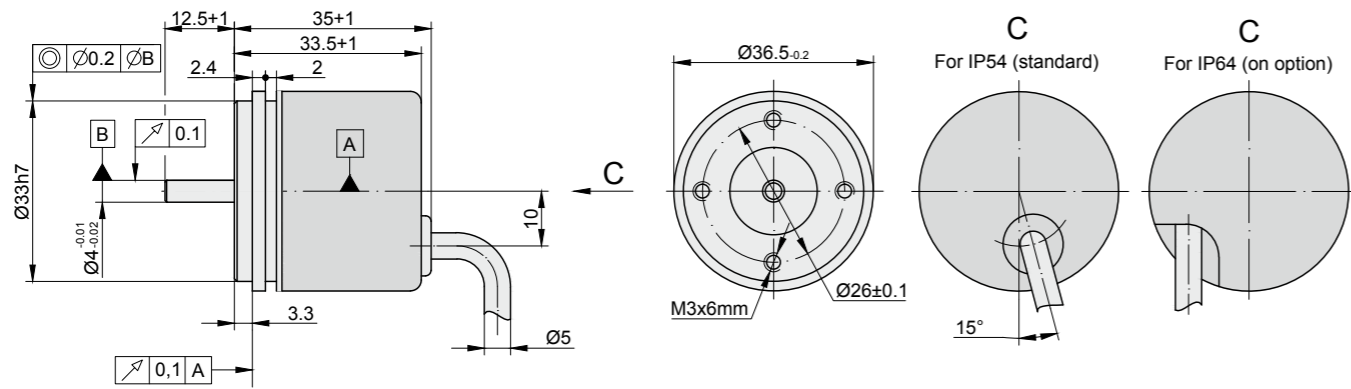

## AM58

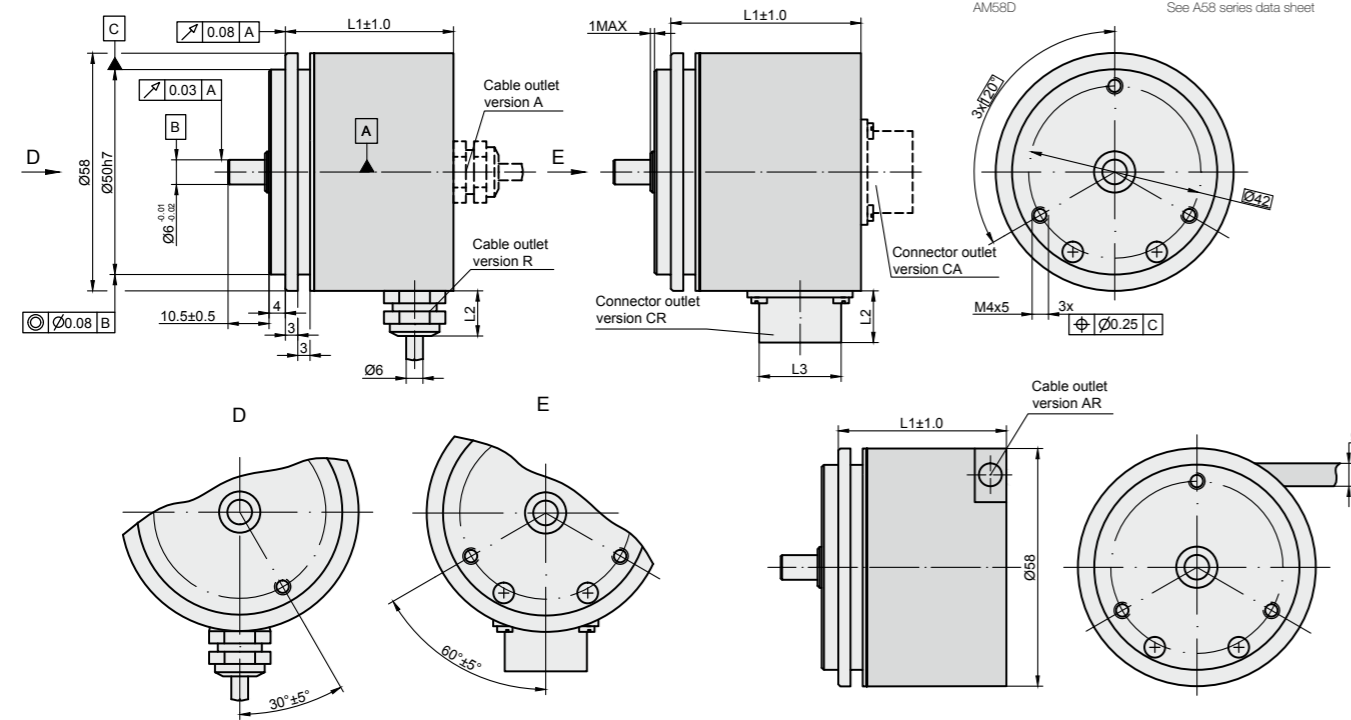

ENCODER MODIFICATION	OTHER MODIFICATIONS
AM58M	See A58 series data sheet
AM58B	See A58 series data sheet
AM58C	See A58 series data sheet
AM58C2	See A58 series data sheet
AM58C3	See A58 series data sheet
AM58D	See A58 series data sheet

Connector type / cable outlet	ONC axial	RS10 axial	C12, C9 axial	ONC radial	RS10 radial	C12, C9 radial	Cable axial (ver. A)	Cable radial (ver. R)	Cable axial-radial (ver. AR)
L1	41 mm	41 mm	41 mm	54 mm	53 mm	53 mm	41 mm	41 mm	43 mm
L2	16 mm	9 mm	22 mm	16 mm	9 mm	22 mm	12 mm	12 mm	-
L3	M24	M14	M23	M24	M14	M23	-	-	-

## MECHANICAL DATA

AM58		AM36	
Maximum shaft speed	12000 rpm	Maximum shaft speed	10000 rpm
Maximum shaft load:		Maximum shaft load:	
- axial	10 N	- axial	5 N
- radial (at shaft end)	20 N	- radial (at shaft end)	10 N
Starting torque at 20°C	≤ 0.01 Nm	Starting torque at 20°C	≤ 0.002 Nm
Rotor moment of inertia	< 15 gcm <sup>2</sup>	Rotor moment of inertia	< 2 gcm <sup>2</sup>
Protection (IEC 529)	up to IP67	Protection (IEC 529)	up to IP64
Maximum weight without cable	0.25 kg	Maximum weight without cable	0.07 kg
Operating temperature	-25...+85 °C	Operating temperature	-25...+85 °C
Storage temperature	-40...+125 °C	Storage temperature	-40...+125 °C
Maximum humidity (non-condensing)	98 %	Maximum humidity (non-condensing)	98 %
Permissible vibration (55 to 2000 Hz)	≤ 100 m/s <sup>2</sup>	Permissible vibration (55 to 2000 Hz)	≤ 100 m/s <sup>2</sup>
Permissible shock (5 ms)	≤ 300 m/s <sup>2</sup>	Permissible shock (5 ms)	≤ 300 m/s <sup>2</sup>

## ELECTRICAL DATA

Supply voltage	+5V±5%
- standard	+5V±5%
- optional	+(10...30)V±5%
Light source	LED
Accuracy	±0.3 arc. degree
Resolution	2 <sup>12</sup> (4096)
Code	binary
Output signals:	
- incremental	TTL, HTL
- through synchronous serial interface	SSI
- commutation	UVW (pole number 2, 4, 6, 8, 10, 12, 14, 16)
Maximum operating frequency, kHz	300
Standard cable length	1m, without connector
Maximum cable length	25m

## OUTPUT SIGNALS

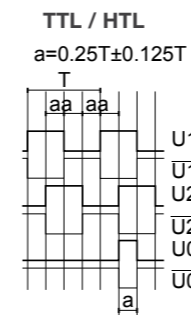

### SSI timing diagram

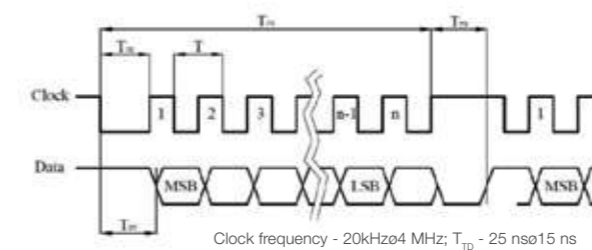

### UVW

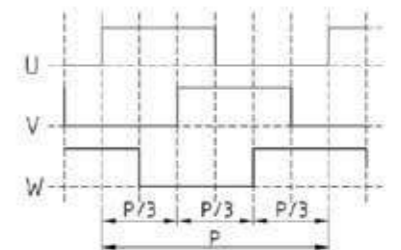

## ACCESSORIES

CONNECTORS FOR CABLE	C9 9-pin round connector	C12 12-pin round connector	D9 9-pin flat connector
COUPLING	SC30		

## ORDER FORM

AMX1 - X2 - X3 - X4 - X5 - X6/X7

Encoder Modification (X1):	Output signal version (X2):	Pole number for signal uvw (X3):	Bit number (X4):	Voltage Supply (X5):	Cable length and output (X6):	Connector type (X7):
36 - AM36	H1 - TTL	P2 - 2	B6 - 6	05V - +5V	A01 - 1m (axial)	W - without connector
58M - AM58M	H2 - UVW	P4 - 4	B8 - 8	30V - +(10 to 30)V	A02 - 2m (axial)	D9 - flat, 9 pin
58B - AM58B	H3 - TTL-UVW	P6 - 6	B10 - 10		R03 - 3m (radial)	C9 - round, 9pin
58C - AM58C	H4 - TTL-SSI	P8 - 8	B12 - 12			C12 - round, 12pin
58C2 - AM58C2	H5 - TTL - UVW - SSI	P10 - 10				PC10 - round, 10 pin
58C3 - AM58C3	H6 - HTL	P12 - 12				
58D - AM58D	H7 - HTL - UVW	P14 - 14				
	H8 - HTL - UVW - SSI	P16 - 16				

ORDER EXAMPLES: 1) AM36-H3-P6-6-05V-R01/W  
2) AM58M-H4-B12-30V-A01/D9



# ANGLE ENCODERS



MODEL	CROSS SECTION	NUMBER OF LINES*	ACCURACY (ARC. SEC)	SHAFT TYPE	OUTPUT SIGNALS
<b>A90H</b>		18.000	± 5	Hollow shaft w/ integrated stator coupling	~ 11 uApp ~ 1 Vpp TTL
<b>A110</b>		18.000	± 5	Solid shaft	~ 11 uApp ~ 1 Vpp TTL
<b>A110H</b>		18.000	± 5	Hollow shaft w/ integrated stator coupling	~ 11 uApp ~ 1 Vpp TTL

MODEL	CROSS SECTION	NUMBER OF LINES*	ACCURACY (ARC. SEC)	SHAFT TYPE	OUTPUT SIGNALS
<b>A170</b>		18.000 / 36.000	± 2.5	Solid shaft	~ 11 uApp ~ 1 Vpp TTL
<b>A170H</b>		18.000 / 36.000	± 2.5	Hollow shaft w/ integrated stator coupling	~ 11 uApp ~ 1 Vpp TTL
<b>A200H</b>		36.000	± 2	Hollow shaft w/ integrated stator coupling	~ 11 uApp ~ 1 Vpp TTL

\*possible interpolation factor up to x100.

PHOTOELECTRIC ANGLE ENCODER

# A90H

- Analog output signals
- High Resolutions
- Hollow Shaft
- Distance Coded reference mark
- High Precision



Photoelectric angle encoder A90H is a high end incremental encoder that produces up to 1.800.000 output pulses per revolution. It has hollow shaft, integrated stator coupling and the accuracy of

up to ±5 arc. sec. and is available in two different mounting types – coupling via shaft collar or via central screw.

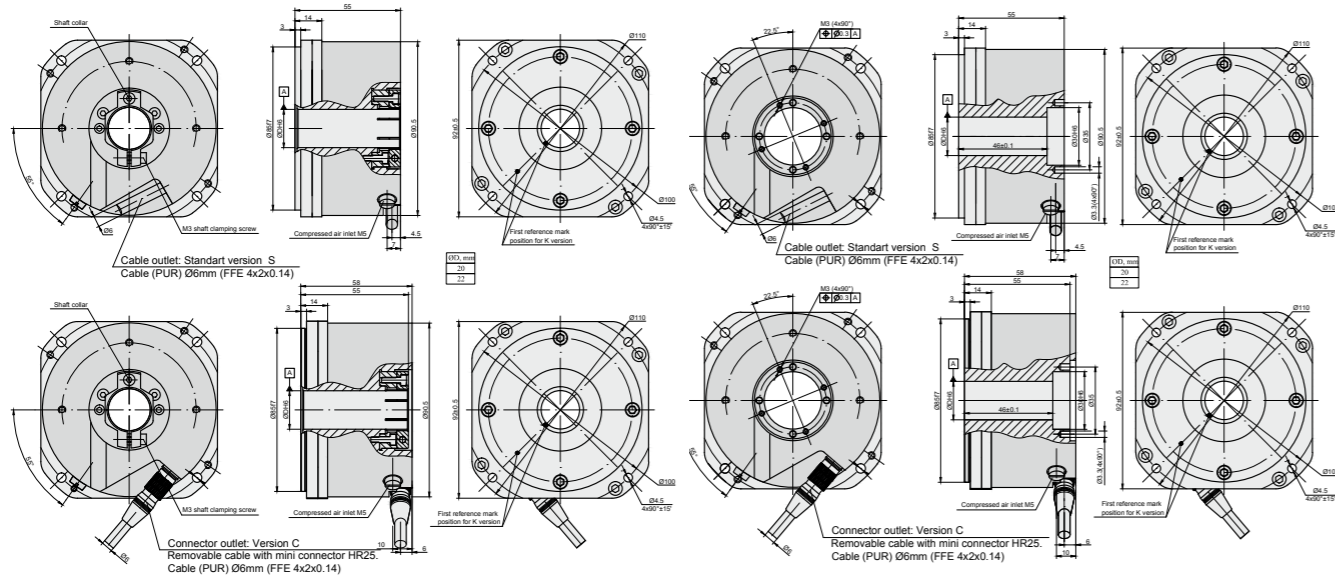

MOUNTING TYPE H (SCREW)

øD, mm
20
22

MOUNTING TYPE P (CLAMP)

øD, mm
20
22

For highest quality up-to-date drawings please refer to our website [www.precizika.com](http://www.precizika.com)

## MECHANICAL DATA

Line number on disc (z)	18000	Permissible shaft run out:	
Number of output pulses per revolution for A90H-F	Z x k, where k = 1, 2, 3, 4, 5, 8, 10, 20, 25, 50, 100	- axial	0.02 mm
Reference signal:		- radial	0.02 mm
- standard (S)	one per shaft revolution	Rotor moment of inertia	< 0.6 × 10 <sup>-4</sup> kgm <sup>2</sup>
- distance-coded (K)	36 per shaft revolution	Protection (IEC 529)	IP64
Permissible mech. speed	≤ 3000 rp	Maximum weight without cable	1.2 kg
Max. operating speed (depends on number of output pulses)	600 to 1000 rpm	Operating temperature	0...+70 °C
Accuracy grades	±5.0 arc. sec	Storage temperature	-30...+85 °C
Starting torque at 20°C	≤ 0.08 Nm	Maximum humidity (non condensing)	98 %
		Permissible vibration (55 to 2000 Hz)	≤ 100 m/s <sup>2</sup>
		Permissible shock (5 ms)	≤ 300 m/s <sup>2</sup>

## ACCESSORIES

CONNECTORS FOR CABLE	B12 12-pin round connector	C9 9-pin round connector	C12 12-pin round connector	D9 9-pin flat connector	D15 15-pin flat connector	RS10 10-pin round connector	ONC 10-pin round connector
DIGITAL READOUT DEVICES	CS3000			CS5500			
EXTERNAL INTERPOLATOR	NK						

## ELECTRICAL DATA

Version	A90H-A ~ 11 µApp	A90H-AV ~ 1 Vpp	A90H-F □ TTL
Supply voltage (U <sub>p</sub> )	+5V ± 5%	+5V ± 5%	+5V ± 5%;
Max. supply current (without load)	100 mA	120 mA	150 mA
Light source	LED	LED	LED
Incremental signals	Two sinusoidal I <sub>1</sub> and I <sub>2</sub> Amplitude at 1 kΩ load: - I <sub>1</sub> = 7...16 µA - I <sub>2</sub> = 7...16 µA	Differential sine +A/-A and +B/-B Amplitude at 120 Ω load: - A = 0.6...1.2 V - B = 0.6...1.2 V	Differential square-wave U1/U1 and U2/U2. Signal levels at 20 mA load current: - low (logic "0") ≤ 0.5 V - high (logic "1") ≥ 2.4 V
Reference signal	One quasi-triangular I <sub>0</sub> peak per revolution. Signal magnitude at 1 kΩ load: - I <sub>0</sub> = 2...8 µA (usable component)	One quasi-triangular +R and its complementary -R per revolution. Signals magnitude at 120Ω load - R = 0.2...0.8 V (usable component)	One differential square-wave U0/U0 per revolution. Signal levels at 20 mA load current: - low (logic "0") < 0.5 V - high (logic "1") > 2.4 V
Fault detection signal Ūs*	- - no error occur - error occur	one square-wave pulse high low	one square-wave pulse high low
Maximum operating frequency	(-3 dB) ≥ 160 kHz	(-3 dB) ≥ 180 kHz	160-2000 kHz (depends on interpolation factor)
Direction of signals	I <sub>2</sub> lags I <sub>1</sub> for clockwise rotation (viewed from encoder mounting side)	+B lags +A for clockwise rotation (viewed from encoder mounting side)	U2 lags U1 with clockwise rotation (viewed from encoder mounting side)
Maximum rise and fall time	-	-	< 0.2 µs
Standard cable length	1 m, without connector	1 m, without connector	1 m, without connector
Maximum cable length	5 m	25 m	25 m

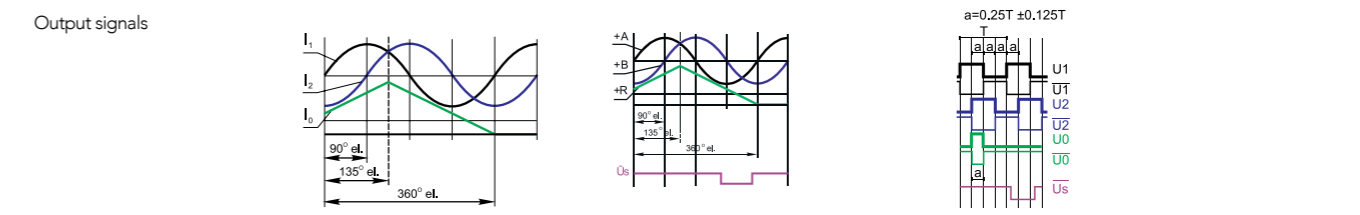

\*not available for version with removable cable

Note:

- Maximum working rotation speed (with proper encoder counting) is limited by maximum operating frequency and maximum mechanical rotation speed.
- If cable extension is used, power supply conductor cross-section should not be smaller than 0.5 mm<sup>2</sup>.

## MOUNTING REQUIREMENTS

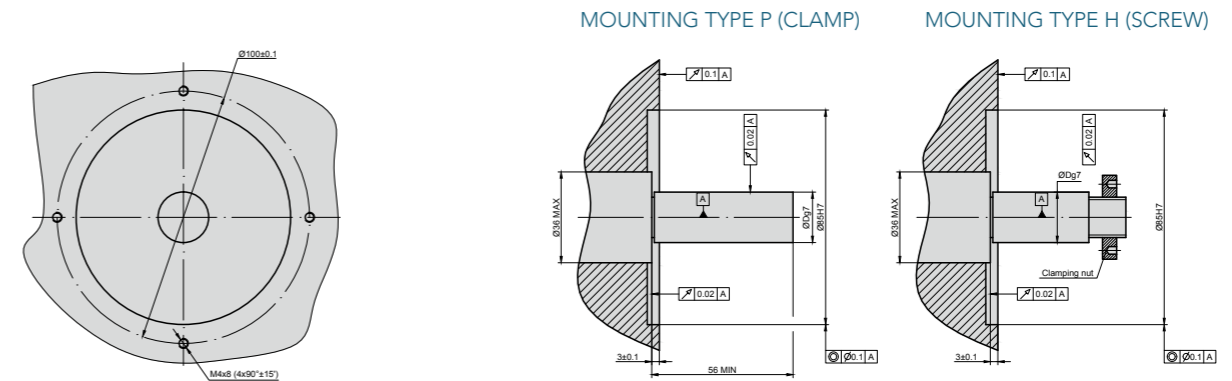

## ORDER FORM

<b>A90H</b>	- X1 - X2 - X3 - X4 - X5 - X6 - X7/X8						
Output signal version (X1):	Pulse number per revolution (X2):	Reference signal (X3):	Diameter of shaft hole (X4):	Mounting type (X5):	Cable or connector Outlet (X6):	Cable Length (X7):	Connector type (X8):
<b>A</b> <b>AV</b> <b>F</b>	<b>18000</b> ... <b>1800000*</b>	<b>S</b> - one per revolution <b>K</b> - 36 per revolution, distance-coded	<b>20</b> - 20mm <b>22</b> - 22mm	<b>P</b> - clamp <b>H</b> - screw	<b>S</b> - version S (cable outlet) <b>C</b> - version C (connector outlet)	<b>AR01</b> - 1m <b>AR02</b> - 2m <b>AR03</b> - 3m ....	<b>W</b> - without connector <b>B12</b> - round, 12 pins <b>C9</b> - round, 9 pins <b>C12</b> - round, 12 pins <b>D9</b> - flat, 9 pins <b>D15</b> - flat, 15 pins <b>RS10</b> - round, 10 pins <b>ONC</b> - round, 10 pins

ORDER EXAMPLE: 1) A90H-A-18000-K-20-P-S-AR01/W

# PHOTOELECTRIC ANGLE ENCODER

# A110

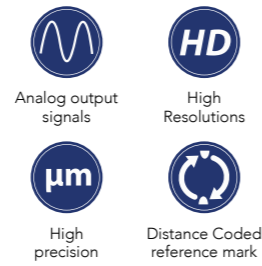

Photoelectric angle encoder A110 is a similar high end encoder to A90H, but with a solid shaft. It is able to produce up to 1.800.000

output pulses per revolution and can have a modification with a distance-coded reference mark.

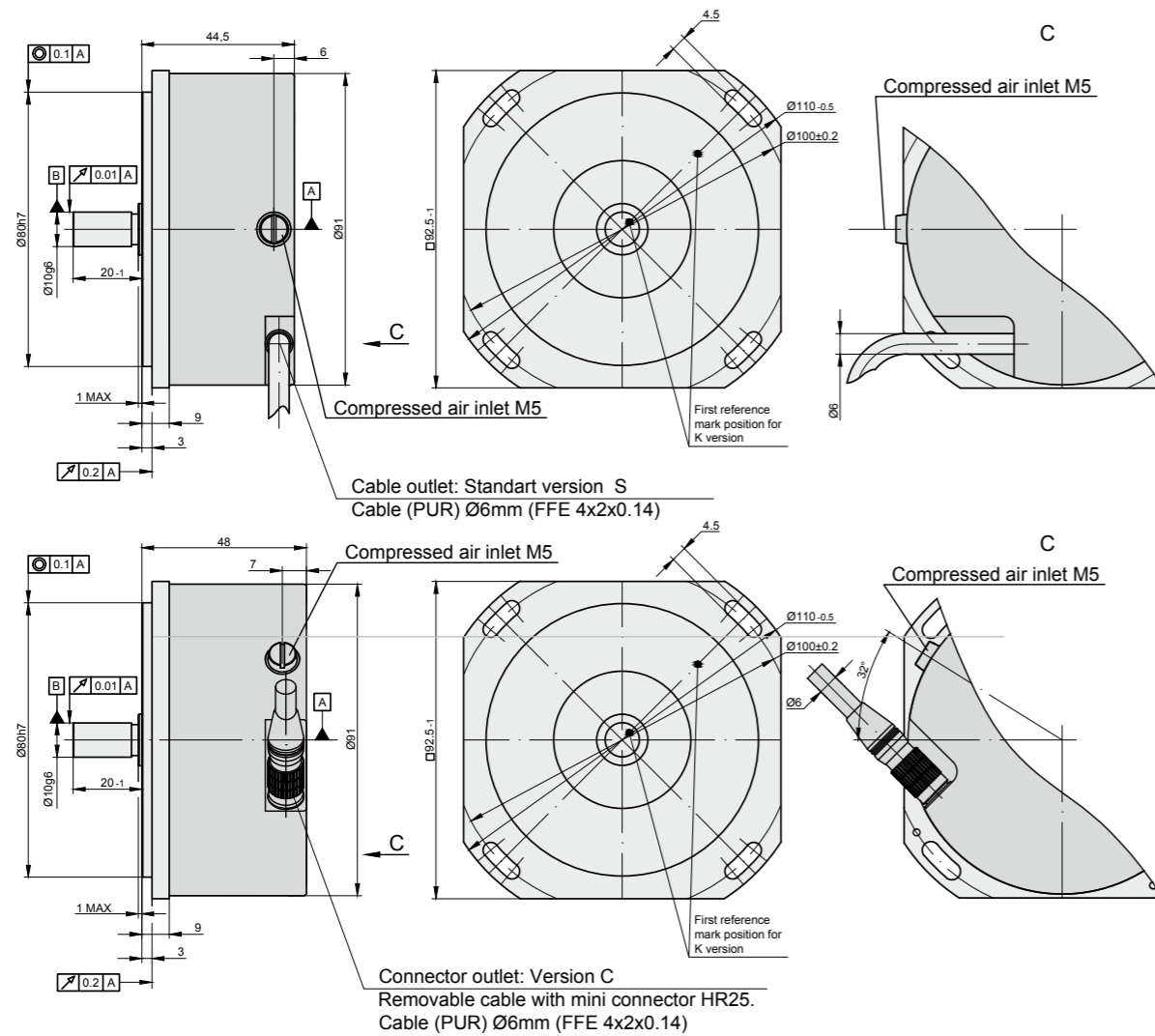

## MECHANICAL DATA

Line number on disc (z)	18000	Accuracy	±5.0 arc. sec
Number of output pulses per revolution for A110-F	Z x k, where k = 1, 2, 3, 4, 5, 8, 10, 20, 25, 50, 100.	Starting torque at 20°C	≤ 0.01Nm
Reference signal: - standard (S) - distance-coded (K)	one per shaft revolution 36 per shaft revolution	Rotor moment of inertia	< 20×10 <sup>-6</sup> kgm <sup>2</sup>
Maximum shaft speed	5000 rpm	Protection (IEC 529)	IP64
Maximum shaft load: - axial - radial (at shaft end)	10 N 10 N	Maximum weight without cable	0.7 kg
		Operating temperature	0...+50 °C
		Storage temperature	-30...+80°C
		Maximum humidity (non condensing)	98 %
		Permissible vibration	≤ 100 m/s <sup>2</sup>
		Permissible shock (6 ms)	≤ 300 m/s <sup>2</sup>

## ELECTRICAL DATA

Version	A110-A ~ 11 µApp	A110-AV ~ 1 Vpp	A110-F TTL
Supply voltage (U <sub>p</sub> )	+5 V ± 5%	+5 V ± 5%	+5 V ± 5%;
Max. supply current (without load)	80 mA	120 mA	120 mA
Light source	LED	LED	LED
Incremental signals	Two sinusoidal I <sub>1</sub> and I <sub>2</sub> Amplitude at 1 kΩ load: - I <sub>1</sub> = 7-16 µA - I <sub>2</sub> = 7-16 µA	Differential sine +A/-A and +B/-B Amplitude at 120 Ω load: - A = 0.6-1.2 V - B = 0.6-1.2 V	Differential square-wave U1/U1̄ and U2/U2̄. Signal levels at 20 mA load current: - low (logic "0") ≤ 0.5 V - high (logic "1") ≥ 2.4 V
Reference signal	One quasi-triangular I <sub>0</sub> peak per revolution. Signal magnitude at 1 kΩ load: - I <sub>0</sub> = 2-8 µA (usable component)	One quasi-triangular +R and its complementary -R per revolution. Signals magnitude at 120Ω load - R = 0.2-0.8 V (usable component)	One differential square-wave U0/U0̄ per revolution. Signal levels at 20 mA load current: - low (logic "0") < 0.5 V - high (logic "1") > 2.4 V
Fault detection signal Ūs*	- - no error occur - error occur	one square-wave pulse high low	one square-wave pulse high low
Maximum operating frequency	(-3 dB) ≥ 160 kHz	(-3 dB) ≥ 180 kHz	160-2000 kHz (depends on interpolation factor)
Direction of signals	I <sub>2</sub> lags I <sub>1</sub> for clockwise rotation (viewed from shaft side)	+B lags +A for clockwise rotation (viewed from shaft side)	U2 lags U1 with clockwise rotation (viewed from shaft side)
Maximum rise and fall time	-	-	< 0.5 µs
Standard cable length	1 m, without connector	1 m, without connector	1 m, without connector
Maximum cable length	5 m	25 m	25 m
Output signals			

\*not available for version with removable cable

Note:

- Maximum working rotation speed (with proper encoder counting) is limited by maximum operating frequency and maximum mechanical rotation speed.
- If cable extension is used, power supply conductor cross-section should not be smaller than 0.5 mm<sup>2</sup>.

## ACCESSORIES

<b>CONNECTORS FOR CABLE</b>	B12 12-pin round connector	C9 9-pin round connector	C12 12-pin round connector	D9 9-pin flat connector	D15 15-pin flat connector	RS10 10-pin round connector	ONC 10-pin round connector
<b>DIGITAL READOUT DEVICES</b>	CS3000					CS5500	
<b>COUPLING</b>	SC70						
<b>EXTERNAL INTERPOLATOR</b>	NK						

## ORDER FORM

<b>A110</b>	- X1	- X2	- X3	- X4	- X5/X6
Output signal version (X1):	Pulse number per revolution (X2):	Reference signal (X3):	Cable or connector Outlet (X4):	Cable Length (X5):	Connector type (X6):
<b>A</b> <b>AV</b> <b>F</b>	<b>18000</b> ... <b>1800000*</b>	<b>S</b> - one per revolution <b>K</b> - 36 per revolution, distance-coded	<b>S</b> - version S (cable outlet) <b>C</b> - version C (connector outlet)	<b>AR01</b> - 1m <b>AR02</b> - 2m <b>AR03</b> - 3m ....	<b>W</b> - without connector <b>B12</b> - round, 12 pins <b>C9</b> - round, 9 pins <b>C12</b> - round, 12 pins <b>D9</b> - flat, 9 pins <b>D15</b> - flat, 15 pins <b>RS10</b> - round, 10 pins <b>ONC</b> - round, 10 pins
*only F signal version for >18000 pulses					
ORDER EXAMPLE: 1) A110-F-18000-K-S-AR02/C12					

PHOTOELECTRIC ANGLE ENCODER

# A110H



A110H is a photoelectric hollow shaft angle encoder that produces up to 1.800.000 output pulses per revolution and has the accuracy of ±5 arc. sec.

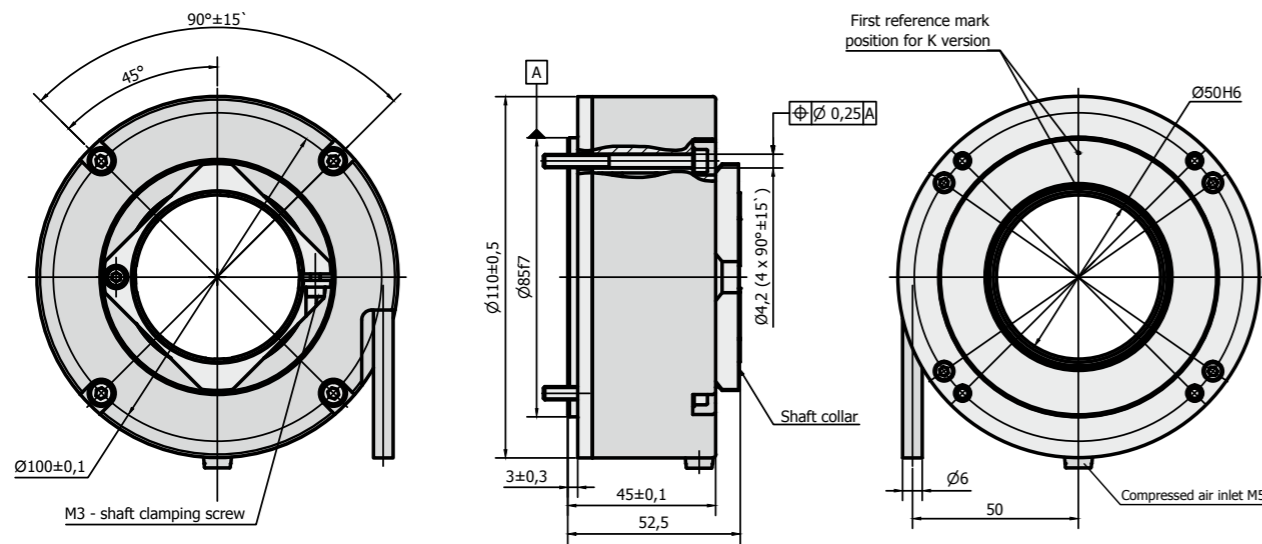

## MOUNTING REQUIREMENTS

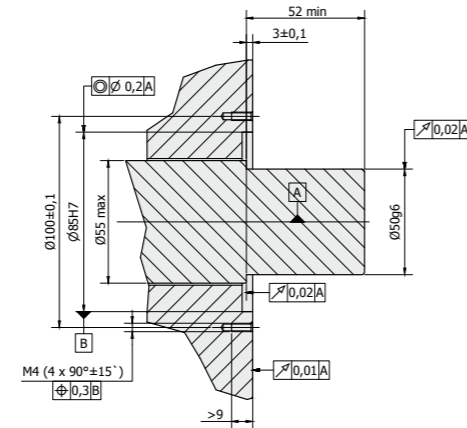

## MECHANICAL DATA

Line number on disc (Z)	18000	Permissible shaft runout: - axial - radial	0.02 mm 0.05 mm
Number of output pulses per revolution	Z x k, where k = 1, 2, 3, 4, 5, 8, 10, 20, 25, 50, 100 (k - interpolation factor)	Starting torque at 20°C	≤ 0.08 Nm
Reference signal: - standard (S) - distance-coded (K)	One per shaft revolution 36 per shaft revolution	Rotor moment of inertia	<math>< 0.6 \times 10^{-4} \text{ kgm}^2</math>
Permissible mech. speed	≤ 3000 rpm	Protection (IEC 529)	IP64
Max. operating speed (depends on number of output pulses)	600 to 1000 rpm	Maximum weight without cable	1.2 kg
Accuracy grades:	±5.0 arc. sec	Operating temperature	0...+70 °C
		Storage temperature	-30...+85°C
		Maximum humidity (non condensing)	98 %
		Permissible vibration	≤ 100 m/s <sup>2</sup>
		Permissible shock (6 ms)	≤ 300 m/s <sup>2</sup>

## ELECTRICAL DATA

Version	A110H-A ~ 11 μApp	A110H-AV ~ 1 Vpp	A110H-F TTL
Supply voltage (U <sub>p</sub> )	+5 V ± 5%	+5 V ± 5%	+5 V ± 5%;
Max. supply current (without load)	100 mA	120 mA	120 mA
Light source	LED	LED	LED
Incremental signals	Two sinusoidal I <sub>1</sub> and I <sub>2</sub> Amplitude at 1 kΩ load: - I <sub>1</sub> = 7-16 μA - I <sub>2</sub> = 7-16 μA	Differential sine +A/-A and +B/-B Amplitude at 120 Ω load: - A = 0.6-1.2 V - B = 0.6-1.2 V	Differential square-wave U1/U1 and U2/U2. Signal levels at 20 mA load current: - low (logic "0") ≤ 0.5 V - high (logic "1") ≥ 2.4 V
Reference signal	One quasi-triangular I <sub>0</sub> peak per revolution. Signal magnitude at 1 kΩ load: - I <sub>0</sub> = 2-8 μA (usable component)	One quasi-triangular +R and its complementary -R per revolution. Signals magnitude at 120 Ω load - R = 0.2-0.8 V (usable component)	One differential square-wave U0/U0 per revolution. Signal levels at 20 mA load current: - low (logic "0") < 0.5 V - high (logic "1") > 2.4 V
Fault detection signal Ūs	- no error occur - error occur	one square-wave pulse high low	one square-wave pulse high low
Maximum operating frequency	(-3 dB) ≥ 160 kHz	(-3 dB) ≥ 180 kHz	160-2000 kHz (depends on interpolation factor)
Direction of signals	I <sub>2</sub> lags I <sub>1</sub> for clockwise rotation (viewed from shaft side)	+B lags +A for clockwise rotation (viewed from shaft side)	U2 lags U1 with clockwise rotation (viewed from shaft side)
Maximum rise and fall time	-	-	< 0.5 μs
Standard cable length	1 m, without connector	1 m, without connector	1 m, without connector
Maximum cable length	5 m	25 m	25 m

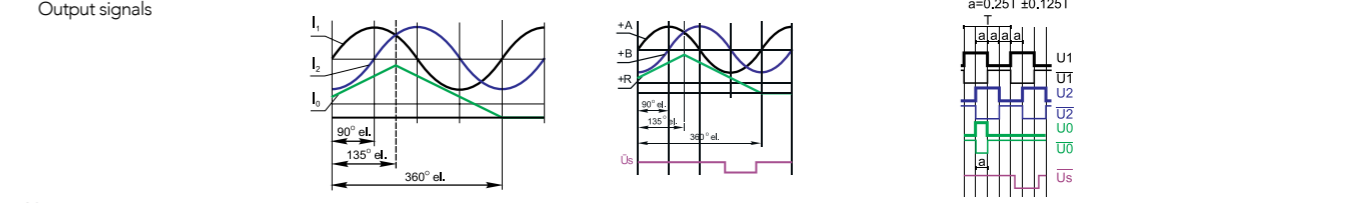

- Note:
- Maximum working rotation speed (with proper encoder counting) is limited by maximum operating frequency and maximum mechanical rotation speed.
  - If cable extension is used, power supply conductor cross-section should not be smaller than 0.5 mm<sup>2</sup>.

## ACCESSORIES

CONNECTORS FOR CABLE	B12 12-pin round connector	C9 9-pin round connector	C12 12-pin round connector	D9 9-pin flat connector	D15 15-pin flat connector	RS10 10-pin round connector	ONC 10-pin round connector
DIGITAL READOUT DEVICES			CS3000			CS5500	
COUPLING				SC70			
EXTERNAL INTERPOLATOR				NK			

## ORDER FORM

A110H	- X1	- X2	- X3	- X4/X5
Output signal version (X1): A AV F	Pulse number per revolution (X2): 18000 ... 1800000*	Reference signal (X3): S - one per revolution K - 36 per revolution, distance-coded	Cable Length (X4): AR01 - 1m AR02 - 2m AR03 - 3m ....	Connector type (X5): W - without connector B12 - round, 12 pins C9 - round, 9 pins C12 - round, 12 pins D9 - flat, 9 pins D15 - flat, 15 pins RS10 - round, 10 pins ONC - round, 10 pins

ORDER EXAMPLE: 1) A110H-A-18000-K-AR01/W-0



# PHOTOELECTRIC ANGLE ENCODER

# A170

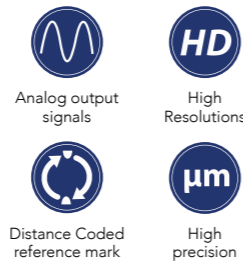

Phototelectric angle encoder A170 is a wide diameter solid shaft high end encoder that produces up to 3.600.000 output pulses per revolution and can reach accuracy of up to ±2.5 arc. sec.

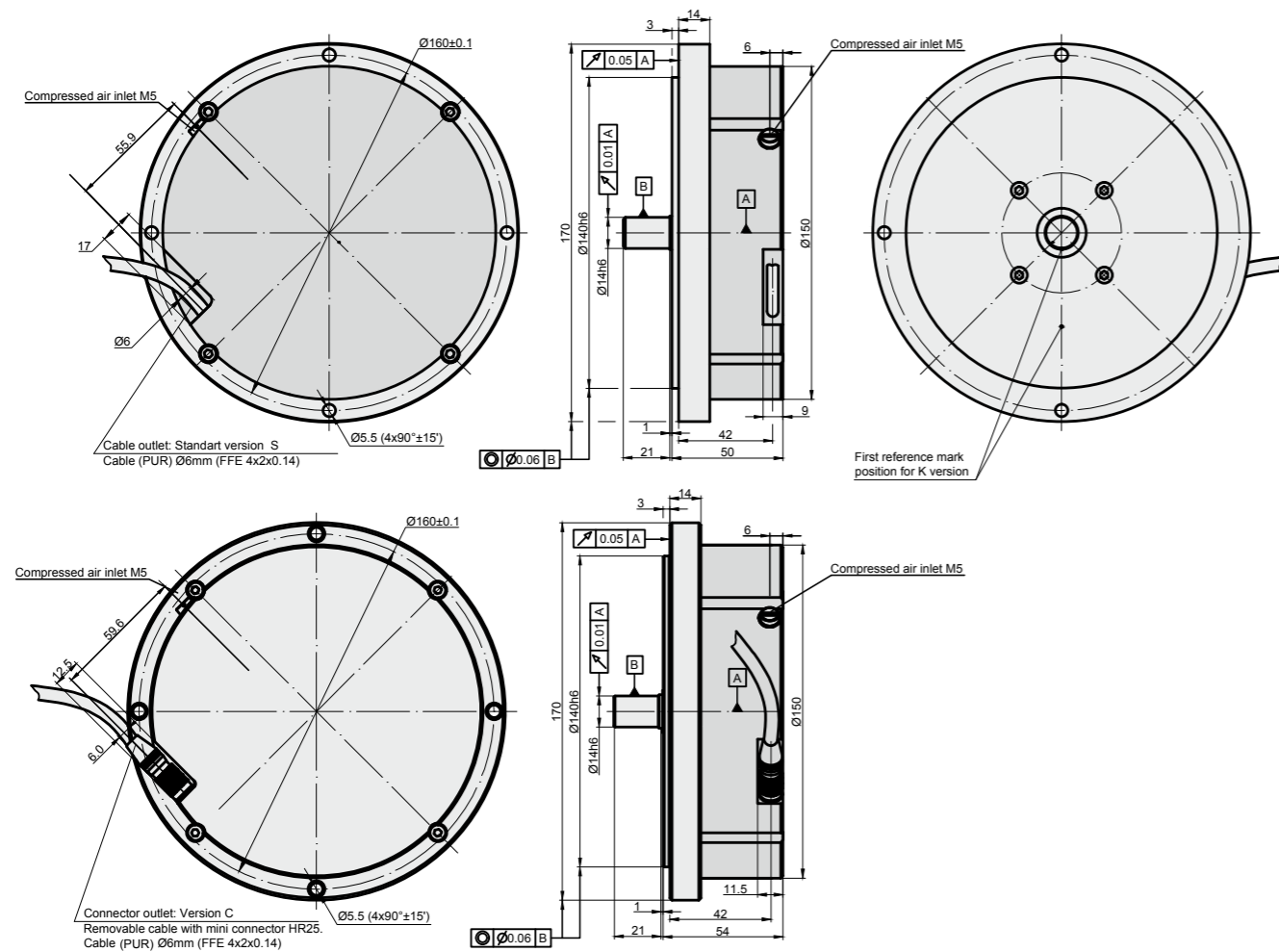

## MECHANICAL DATA

Line number on disc (Z)	18000, 36000	Permissible shaft load:	
Number of output pulses per revolution for A170-F	Z x k, where k = 1, 2, 3, 4, 5, 8, 10, 20, 25, 50, 100	- axial	≤ 30 N
		- radial	≤ 30 N
Starting torque at 20°C	≤ 0.012 Nm	Rotor moment of inertia	< 3.7 × 10 <sup>-4</sup> kgm <sup>2</sup>
Reference signal:		Protection (IEC 529)	IP64
- standard (S)	One per shaft revolution	Maximum weight without cable	3.5 kg
- distance-coded (K) for z = 18000	36 per shaft revolution	Operating temperature	0...+70 °C
- distance-coded (K) for z = 36000	72 per shaft revolution	Storage temperature	-30...+85°C
Permissible mech. speed	≤ 1000 rpm	Maximum humidity (non condensing)	98 %
Max. operating speed (depends on number of output pulses)	300 to 500 rpm	Permissible vibration	≤ 100 m/s <sup>2</sup>
Accuracy	±2.5	Permissible shock (6 ms)	≤ 300 m/s <sup>2</sup>

## ELECTRICAL DATA

Version	A170-A ~ 11 µApp	A170-AV ~ 1 Vpp	A170-F TTL
Supply voltage (U <sub>p</sub> )	+5 V ± 5% 100 mA max.	+5 V ± 5% 120 mA max.	+5 V ± 5%; 150 mA max.
Light source	LED	LED	LED
Incremental signals	Two sinusoidal I <sub>1</sub> and I <sub>2</sub> Amplitude at 1 kΩ load: - I <sub>1</sub> = 7...16 µA - I <sub>2</sub> = 7...16 µA	Differential sine +A/-A and +B/-B Amplitude at 120 Ω load: - A = 0.6...1.2 V - B = 0.6...1.2 V	Differential square-wave U1/Ū1 and U2/Ū2. Signal levels at 20 mA load current: - low (logic "0") ≤ 0.5 V - high (logic "1") ≥ 2.4 V
Reference signal	One quasi-triangular I <sub>0</sub> peak per revolution. Signal magnitude at 1 kΩ load: - I <sub>0</sub> = 2...8 µA (usable component)	One quasi-triangular +R and its complementary -R per revolution. Signals magnitude at 120 Ω load - R = 0.2...0.8 V (usable component)	One differential square-wave U0/Ū0 per revolution. Signal levels at 20 mA load current: - low (logic "0") < 0.5 V - high (logic "1") > 2.4 V
Maximum operating frequency	(-3 dB cutoff) ≥ 160 kHz	(-3 dB cutoff) ≥ 180 kHz	160-2000 kHz (depends on interpolation factor)
Direction of signals	I <sub>2</sub> lags I <sub>1</sub> for clockwise rotation (viewed from encoder mounting side)	+B lags +A for clockwise rotation (viewed from encoder mounting side)	U2 lags U1 with clockwise rotation (viewed from encoder mounting side)
Maximum rise and fall time	-	-	< 0.5 µs
Standard cable length	1 m, without connector	1 m, without connector	1 m, without connector
Maximum cable length	5 m	25 m	25 m

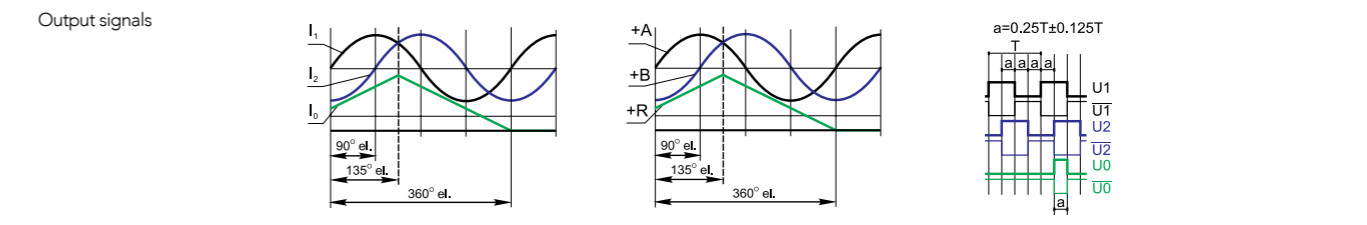

- Note:
- Maximum working rotation speed (with proper encoder counting) is limited by maximum operating frequency and maximum mechanical rotation speed.
  - If cable extension is used, power supply conductor cross-section should not be smaller than 0.5 mm<sup>2</sup>.

## ACCESSORIES

CONNECTORS FOR CABLE	B12 12-pin round connector	C9 9-pin round connector	C12 12-pin round connector	D9 9-pin flat connector	D15 15-pin flat connector	RS10 10-pin round connector	ONC 10-pin round connector
DIGITAL READOUT DEVICES			CS3000			CS5500	
COUPLING			SC98-1			SC98-2	
EXTERNAL INTERPOLATOR					NK		





## ORDER FORM

A170	X1	X2/X3	X4	X5	X6/X7	
Output signal version (X1):	A	AV	F			
Pulse number per revolution (X2):	18000	...	3600000*			
Optional line number on disc (z) (X3):	18000	36000				
Reference signal (X4):	S	- one per revolution,	K	- distance-coded		
Cable or Connector Outlet (X5):	S	- version S (cable outlet)	C	- version C (connector outlet)		
Cable Length (X6):	AR01 - 1m	AR02 - 2m	AR03 - 3m	...		
Connector type (X7):	W	- without connector	B12	- round, 12 pins	C9	- round, 9 pins
			C12	- round, 12 pins	D9	- flat, 9 pins
			D15	- flat, 15 pins	RS10	- round, 10 pins
			ONC	- round, 10 pins		

ORDER EXAMPLES: 1) A170-F-360000/36000-K-C-AR01/C12  
2) A170-F-360000-K-S-AR01/C12

# PHOTOELECTRIC ANGLE ENCODER

# A170H

-  Analog output signals
-  High Resolutions
-  Hollow Shaft
-  Distance Coded reference mark
-  High precision



Photoelectric angle encoder A170H is the high end encoder of the product range. It has a hollow shaft and an integrated stator cou-

pling and is capable of producing up to 3.600.000 output pulses per revolution with the accuracy that can reach up to ±2.5 arc. sec.

## MOUNTING TYPE H (SCREW)

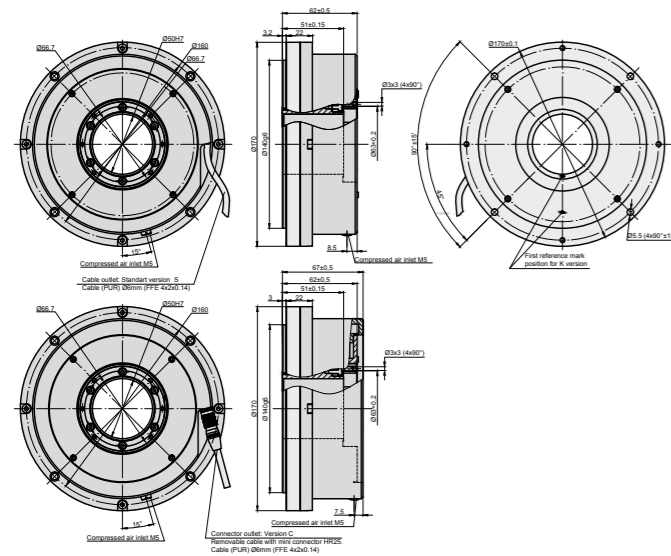

## MOUNTING TYPE P (CLAMP)

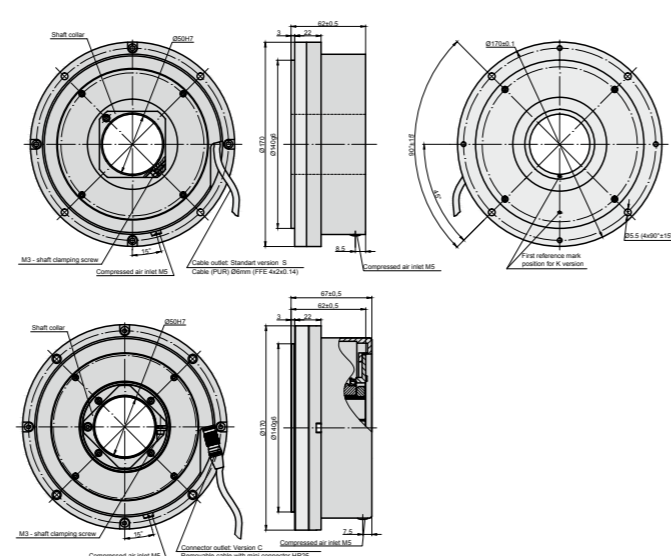

For highest quality up-to-date drawings please refer to our website [www.precizika.com](http://www.precizika.com)

## MECHANICAL DATA

Line number on disc (Z)	18000, 36000
Number of output pulses per revolution for A170-F	Z x k, where k = 1, 2, 3, 4, 5, 8, 10, 20, 25, 50, 100
Reference signal:	
- standard (S)	one per shaft revolution
- distance coded (K) for z = 18000	36 per shaft revolution
- distance coded (K) for z = 36000	72 per shaft revolution
Permissible mech. speed	≤ 1000 rpm
Max. operating speed (depends on number of output pulses)	300 to 500 rpm
Permissible shaft load:	
- axial	0,02 mm
- radial	0,02 mm
Accuracy	±2.5 arc. sec

Starting torque at 20°C	≤ 0.5Nm
Rotor moment of inertia	< 0.9×10 <sup>-3</sup> kgm
Protection (IEC 529)	IP64
Maximum weight without cable	4.1 kg
Operating temperature	0...+70 °C
Storage temperature	-30...+85°C
Maximum humidity (non condensing)	98 %
Permissible vibration	≤ 100 m/s <sup>2</sup>
Permissible shock (6 ms)	≤ 300 m/s <sup>2</sup>

## ACCESSORIES

<b>CONNECTORS FOR CABLE</b>	B12 12-pin round connector	C9 9-pin round connector	C12 12-pin round connector	D9 9-pin flat connector	D15 15-pin flat connector	RS10 10-pin round connector	ONC 10-pin round connector
<b>DIGITAL READOUT DEVICES</b>	CS3000		CS5500				
<b>EXTERNAL INTERPOLATOR</b>	NK						

## ELECTRICAL DATA

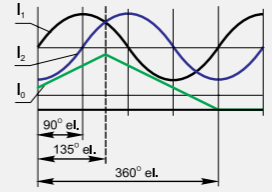
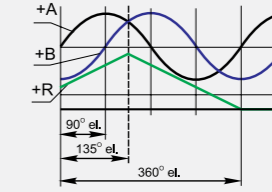
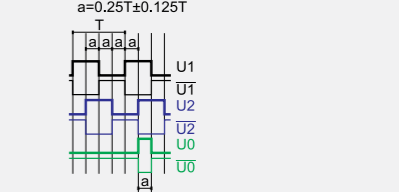
Version	A170H-A ~ 11 μApp	A170H-AV ~ 1 Vpp	A170H-F □ TTL
Supply voltage (U <sub>p</sub> )	+5 V ± 5%	+5 V ± 5%	+5 V ± 5%;
Max. supply current (without load)	100 mA	120 mA	150 mA
Light source	LED	LED	LED
Incremental signals	Two sinusoidal I <sub>1</sub> and I <sub>2</sub> Amplitude at 1 kΩ load: - I <sub>1</sub> = 7...16 μA - I <sub>2</sub> = 7...16 μA	Differential sine +A/-A and +B/-B Amplitude at 120 Ω load: - A = 0.6...1.2 V - B = 0.6...1.2 V	Differential square-wave U1/U1̄ and U2/U2̄. Signal levels at 20 mA load current: - low (logic "0") ≤ 0.5 V - high (logic "1") ≥ 2.4 V
Reference signal	One quasi-triangular I <sub>0</sub> peak per revolution. Signal magnitude at 1 kΩ load: - I <sub>0</sub> = 2...8 μA (usable component)	One quasi-triangular +R and its complementary -R per revolution. Signals magnitude at 120Ω load - R = 0.2...0.8 V (usable component)	One differential square-wave U0/U0̄ per revolution. Signal levels at 20 mA load current: - low (logic "0") < 0.5 V - high (logic "1") > 2.4 V
Maximum operating frequency	(-3 dB cutoff) ≥ 160 kHz	(-3 dB cutoff) ≥ 180 kHz	160-2000 kHz (depends on interpolation factor)
Direction of signals	I <sub>2</sub> lags I <sub>1</sub> for clockwise rotation (viewed from encoder mounting side)	+B lags +A for clockwise rotation (viewed from encoder mounting side)	U2 lags U1 with clockwise rotation (viewed from encoder mounting side)
Maximum rise and fall time	-	-	< 0.5 μs
Standard cable length	1 m, without connector	1 m, without connector	1 m, without connector
Maximum cable length	5 m	25 m	25 m
Output signals			

Note:

- Maximum working rotation speed (with proper encoder counting) is limited by maximum operating frequency and maximum mechanical rotation speed.
- If cable extension is used, power supply conductor cross-section should not be smaller than 0.5 mm<sup>2</sup>.

## MOUNTING REQUIREMENTS

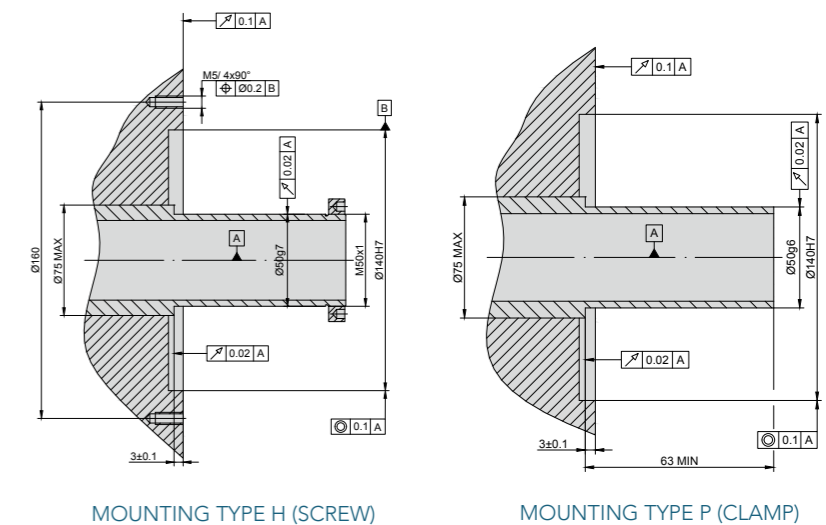





## ORDER FORM

<b>A170H</b>	- X1	- X2/X3	- X4	- X5	- X6	- X7/X8	
Output signal version (X1):	Pulse number per revolution (X2):	Optional line Number on disc (z) (X3):	Reference signal (X4):	Mounting Type (X5):	Cable or Connector Outlet (X6):	Cable Length (X7):	Connector type (X8):
<b>A</b> <b>AV</b> <b>F</b>	<b>18000</b> ... <b>3600000*</b>	<b>18000</b> ... <b>36000</b>	<b>S</b> - one per revolution <b>K</b> - distance-coded	<b>P</b> - clamp <b>H</b> - screw	<b>S</b> - version S (cable outlet) <b>C</b> - version C (connector outlet)	<b>AR01</b> - 1m <b>AR02</b> - 2m <b>AR03</b> - 3m ...	<b>W</b> - without connector <b>B12</b> - round, 12 pins <b>C9</b> - round, 9 pins <b>C12</b> - round, 12 pins <b>D9</b> - flat, 9 pins <b>D15</b> - flat, 15 pins <b>RS10</b> - round, 10 pins <b>ONC</b> - round, 10 pins
*only F signal version for >36000 pulses							
ORDER EXAMPLES: 1) A170H-F-360000/36000-K-P-S-AR01/C12 2) A170H-F-360000-K-H-C-AR01/C12							

PHOTOELECTRIC ANGLE ENCODER

# A200H

-  Analog output signals
-  High Resolutions
-  Hollow Shaft
-  Distance Coded reference mark
-  High precision



Photoelectric angle encoder A200H is the most sophisticated encoder in our product range. It is capable of producing up to 3.600.000 output pulses per revolution and has accuracy of up to

±2.0 arc. sec. Also, it has a 60 mm shaft hole diameter, which sets it apart from other encoders.

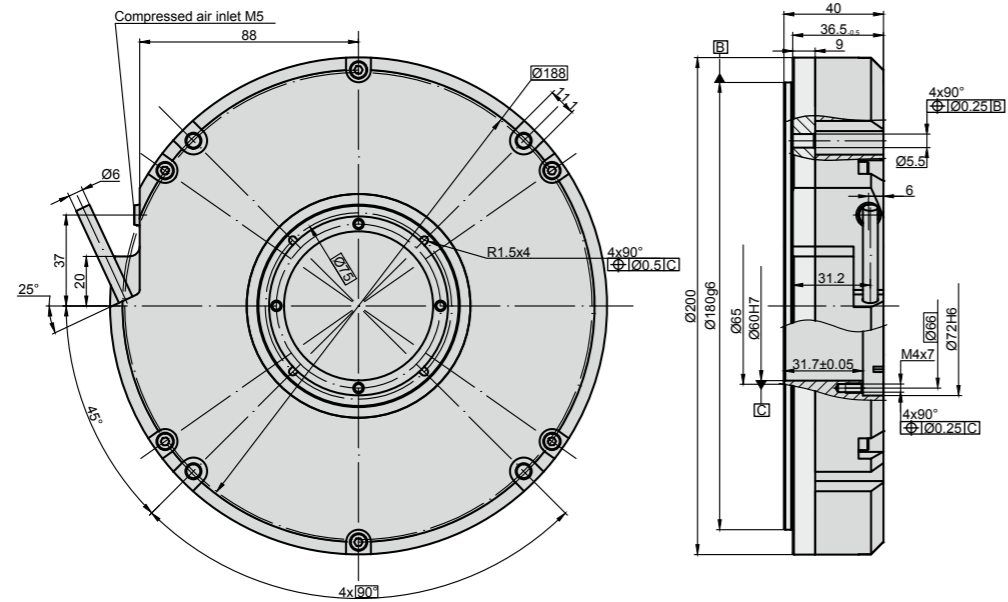

## MECHANICAL DATA

Line number on disc (Z)	36000	Starting torque at 20°C	≤ 0.5Nm
Number of output pulses per revolution for A200-F	Z x k, where k = 1, 2, 3, 4, 5, 8, 10, 20, 25, 50, 100	Rotor moment of inertia	< 0.9×10 <sup>-3</sup> kgm
Reference signal:		Protection (IEC 529)	IP64
- standard (s)	one per shaft revolution	Maximum weight without cable	4.5 kg
- distance coded (K)	72 per shaft revolution	Operating temperature	0...+70 °C
Permissible mech. speed	≤ 1000 rpm	Storage temperature	-30...+85°C
Max. operating speed (depends on number of output pulses)	300 to 500 rpm	Maximum humidity (non condensing)	98 %
Permissible shaft load:		Permissible vibration	≤ 100 m/s <sup>2</sup>
- axial	0,02 mm	Permissible shock (6 ms)	≤ 300 m/s <sup>2</sup>
- radial	0,02 mm		
Accuracy	±2.0 arc. sec		

## ACCESSORIES

CONNECTORS FOR CABLE	B12 12-pin round connector	C9 9-pin round connector	C12 12-pin round connector	D9 9-pin flat connector	D15 15-pin flat connector	RS10 10-pin round connector	ONC 10-pin round connector
DIGITAL READOUT DEVICES	CS3000			CS5500			
EXTERNAL INTERPOLATOR	NK						

## ELECTRICAL DATA

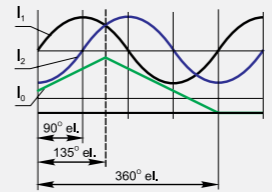
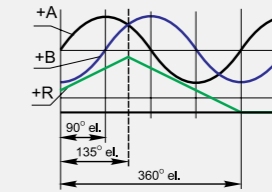
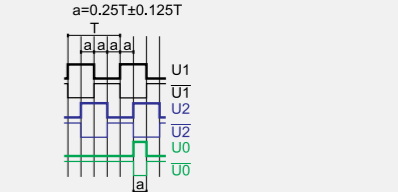
Version	A200H-A ~ 11 μApp	A200H-AV ~ 1 Vpp	A200H-F □ TTL
Supply voltage (U <sub>p</sub> )	+5 V ± 5%	+5 V ± 5%	+5 V ± 5%;
Max. supply current (without load)	100 mA	120 mA	150 mA
Light source	LED	LED	LED
Incremental signals	Two sinusoidal I <sub>1</sub> and I <sub>2</sub> Amplitude at 1 kΩ load: - I <sub>1</sub> = 7...16 μA - I <sub>2</sub> = 7...16 μA	Differential sine +A/-A and +B/-B Amplitude at 120 Ω load: - A = 0.6...1.2 V - B = 0.6...1.2 V	Differential square-wave U1/U1̄ and U2/U2̄. Signal levels at 20 mA load current: - low (logic "0") ≤ 0.5 V - high (logic "1") ≥ 2.4 V
Reference signal	One quasi-triangular I <sub>0</sub> peak per revolution. Signal magnitude at 1 kΩ load: - I <sub>0</sub> = 2...8 μA (usable component)	One quasi-triangular +R and its complementary -R per revolution. Signals magnitude at 120Ω load - R = 0.2...0.8 V (usable component)	One differential square-wave U0/U0̄ per revolution. Signal levels at 20 mA load current: - low (logic "0") < 0.5 V - high (logic "1") > 2.4 V
Maximum operating frequency	(-3 dB cutoff) ≥ 160 kHz	(-3 dB cutoff) ≥ 180 kHz	160-2000 kHz (depends on interpolation factor)
Direction of signals	I <sub>2</sub> lags I <sub>1</sub> for clockwise rotation (viewed from encoder mounting side)	+B lags +A for clockwise rotation (viewed from encoder mounting side)	U2 lags U1 with clockwise rotation (viewed from encoder mounting side)
Maximum rise and fall time	-	-	< 0.5 μs
Standard cable length	1 m, without connector	1 m, without connector	1 m, without connector
Maximum cable length	5 m	25 m	25 m
Output signals			

- Note:
- Maximum working rotation speed (with proper encoder counting) is limited by maximum operating frequency and maximum mechanical rotation speed.
  - If cable extension is used, power supply conductor cross-section should not be smaller than 0.5 mm<sup>2</sup>.

## MOUNTING REQUIREMENTS

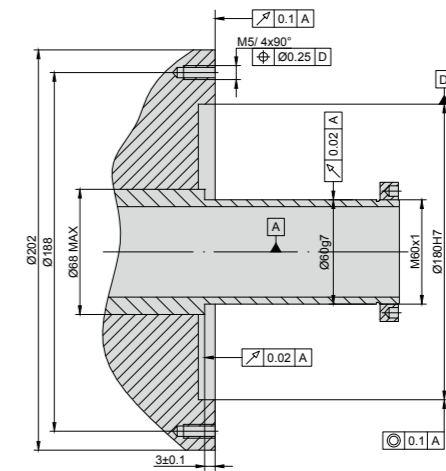

## ORDER FORM

<b>A200H</b>	- X1	- X2	- X3	- X4/X5
Output signal version (X1):	Pulse number per revolution (X2):	Reference signal (X3):	Cable Length (X4):	Connector type (X5):
<b>A</b>	<b>36000</b>	<b>S</b> - one per revolution,	<b>AR01</b> - 1m	<b>W</b> - without connector
<b>AV</b>	<b>3600000*</b>	<b>K</b> - distance-coded	<b>AR02</b> - 2m	<b>B12</b> - round, 12 pins
<b>F</b>			<b>AR03</b> - 3m	<b>C9</b> - round, 9 pins
			...	<b>C12</b> - round, 12 pins
				<b>D9</b> - flat, 9 pins
				<b>D15</b> - flat, 15 pins
				<b>RS10</b> - round, 10 pins
				<b>ONC</b> - round, 10 pins

\*only F signal version for >36000 pulses

ORDER EXAMPLES: 1) A200H-AV-36000-S-AR01/C12  
2) A200H-F-360000-K-AR01/C12

# LINEAR ENCODERS



MODEL	CROSS SECTION	MEASURING LENGTH (MM)	ACCURACY (μM/M)	OUTPUT SIGNALS
L18		70-2040	± 10; ± 5; ± 3	11 uApp 1 Vpp TTL
L18B		70-3240	± 10; ± 5	11 uApp 1 Vpp TTL
L18T		70-1240	± 10; ± 5	11 uApp 1 Vpp TTL
L23		250-20.000	± 10; ± 5; ± 3	TTL
LK24		70-3240	± 5; ± 3	SSI BISS C

MODEL	CROSS SECTION	MEASURING LENGTH (MM)	ACCURACY (μM/M)	OUTPUT SIGNALS
L35		170-3240	± 5; ± 3	11 uApp 1 Vpp TTL
L35T		170-3240	± 10; ± 5; ± 3	11 uApp 1 Vpp TTL
L37		140-3240	± 10; ± 5; ± 3	11 uApp 1 Vpp TTL
L50		3240-30.040	± 10	11 uApp 1 Vpp TTL
MT		Up to 50.000	± 25	1 Vpp TTL
MK		Up to 50.000	± 35	SSI BISS C



# PHOTOELECTRIC LINEAR ENCODER

# L18



Distance Coded reference mark



Analog output signals



Photoelectric linear encoder L18 is an incremental linear displacement measuring device that can have up to 2.040 mm measuring

length, grating period of  $\pm 20 \mu\text{m}$  or  $\pm 40 \mu\text{m}$  and accuracy that can reach up to  $3 \mu\text{m}$ .

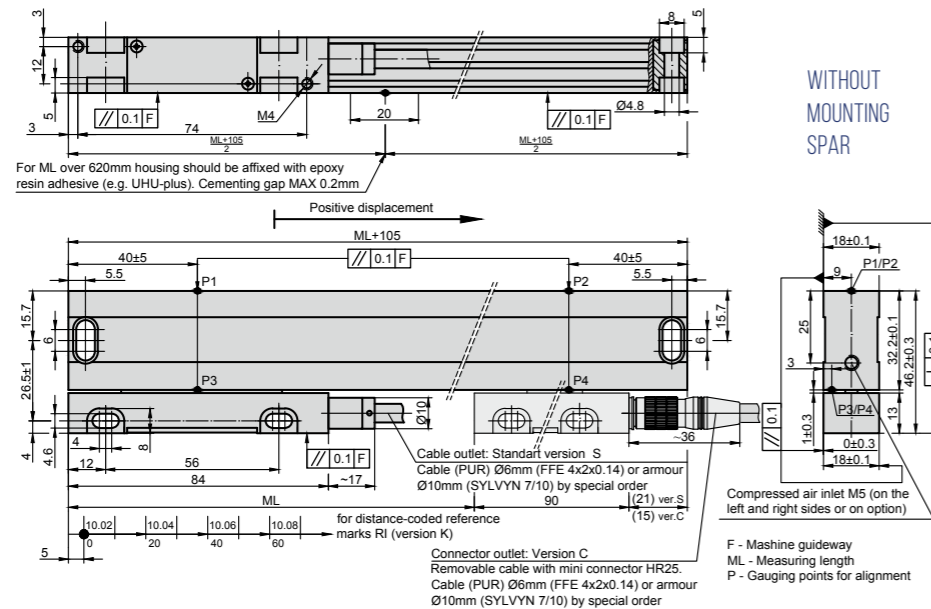
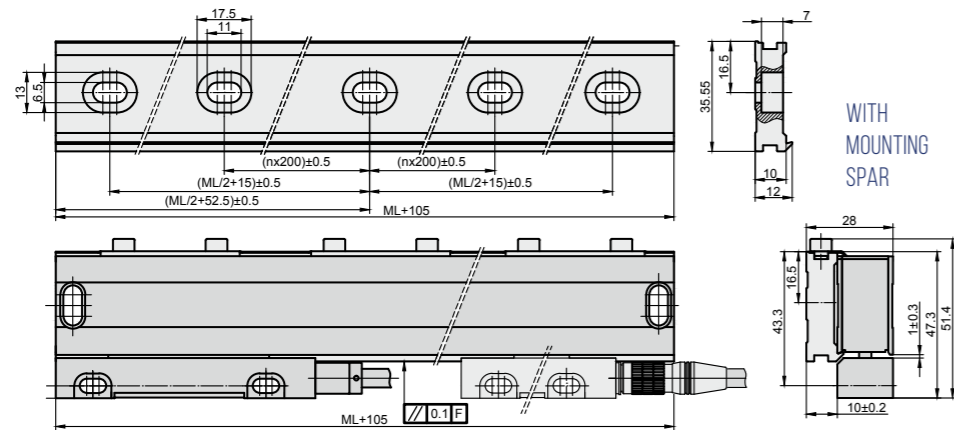

## MECHANICAL DATA

Measuring lengths (ML), mm	70, 120, 170, 220, 270, 320, 370, 420, 520, 620, 720, 820, 920, 1020, 1140, 1240, 1340, 1440, 1540, 1640, 1740, 1840, 1940, 2040 (mounting spar optional up to ML 1240, mandatory from ML 1340 to 2040)	Max. traversing speed: -when interpolation factor is 1,2,5,10 -when interpolation factor is 25 -when interpolation factor is 50	1 m/s 0.5 m/s 0.4 m/s
Accuracy grades to any metre within the ML (at 20°C)	$\pm 10; \pm 5; \pm 3 \mu\text{m}$ (optional)	Required moving force with sealing lips	< 3 N
Grating period	20 $\mu\text{m}$ ; 40 $\mu\text{m}$ (optional)	Protection (IEC 529) -without compressed air -with compressed air (optional)	IP53 IP64
Reference marks (RI): -standard for ML $\leq 1020$ mm -standard for ML > 1140 mm -optional	35mm from both ends of ML 45mm from both ends of ML one RI at any location, or two or more RI's separated by distances of $n \times 50$ mm or distance-coded	Weight	0.4 kg + 0.8 kg/m
		Operating temperature	0...+50°C
		Storage temperature	-20...+70°C
		Permissible vibration (40 to 2000 Hz)	$\leq 30 \text{ m/s}^2$
		Permissible shock (11 ms)	$\leq 100 \text{ m/s}^2$

## ELECTRICAL DATA

Version	L18-A $\sim 11 \mu\text{App}$	L18-AV $\sim 1 \text{Vpp}$	L18-F $\square$ TTL
Power supply	+5 V $\pm 5\%$ / < 90 mA	+5 V $\pm 5\%$ < 120 mA	+5 V $\pm 5\%$ / < 120 mA
Light source	LED	LED	LED
Resolution	Depends on external subdividing electronics	Depends on external subdividing electronics	5; 2.5; 1; 0.5; 0.2; 0.1 $\mu\text{m}$ (after 4-fold dividing in subsequent electronics)
Incremental signals	Two sinusoidal $I_1$ and $I_2$ Amplitude at 1 k $\Omega$ load: - $I_1 = 7\text{-}16 \mu\text{A}$ - $I_2 = 7\text{-}16 \mu\text{A}$	Differential sine +A/-A and +B/-B Amplitude at 120 $\Omega$ load: - A = 0.6-1.2 V - B = 0.6-1.2 V	Differential square-wave $U1/\overline{U1}$ and $U2/\overline{U2}$ . Signal levels at 20 mA load current: - low (logic "0") $\leq 0.5 \text{ V}$ - high (logic "1") $\geq 2.4 \text{ V}$
Reference signal	One quasi-triangular $I_0$ peak per revolution. Signal magnitude at 1 k $\Omega$ load: - $I_0 = 2\text{-}8 \mu\text{A}$ (usable component)	One quasi-triangular +R and its complementary -R per revolution. Signals magnitude at 120 $\Omega$ load - R = 0.2-0.8 V (usable component)	One differential square-wave $U0/\overline{U0}$ per revolution. Signal levels at 20 mA load current: - low (logic "0") < 0.5 V - high (logic "1") > 2.4 V
Maximum operating frequency	50 kHz	50 kHz	50x kHz, when interpolation factor is 1, 2, 5, 10 1000 kHz when interpolation factor is 25, 50
Direction of signals	$I_2$ lags $I_1$ at reading head displacement from left to right	B+ lags A+ at reading head displacement from left to right	$U2$ lags $U1$ at reading head displacement from left to right
Standard cable length	3 m, without connector	3 m, without connector	3 m, without connector
Maximum cable length	5 m	25 m	25 m

Output signals

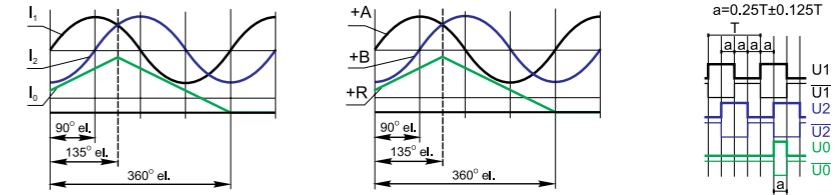

Note: If cable extension is used the power supply conductor section should not be smaller than 0.5 mm<sup>2</sup>.

## ACCESSORIES

<b>CONNECTORS FOR CABLE</b>	B12 12-pin round connector	C9 12-pin round connector	C12 12-pin round connector	D9 9-pin flat connector	D15 15-pin flat connector	RS10 10-pin round connector	ONC 10-pin round connector
<b>DIGITAL READOUT DEVICES</b>	CS3000				CS5500		
<b>EXTERNAL INTERPOLATOR</b>	NK						

## ORDER FORM

L18	X1	X2	X3	X4	X5	X6/X7	X8
Output signals And resolution (X1):	Measuring length (X2):	Reference marks (X3):	Accuracy (X4):	Cable or connector outlet (X5):	Cable length (X6):	Connector type (X7):	Mounting Spar (X8):
A - Sinusoidal AV - Sinusoidal F01 - TTL 0.1 $\mu\text{m}$ F02 - TTL 0.2 $\mu\text{m}$ F05 - TTL 0.5 $\mu\text{m}$ F10 - TTL 1.0 $\mu\text{m}$ F25 - TTL 2.5 $\mu\text{m}$ F50 - TTL 5.0 $\mu\text{m}$	0070 - 70 mm 0520 - 520 mm ... 2040 - 2040 mm	N - none RI S - standard M - every 50 mm K - distance coded Ln/XXX - n RI with 50-fold steps /XXX distance of the first RI from the beginning of ML, mm	03 - $\pm 3 \mu\text{m}$ 05 - $\pm 5 \mu\text{m}$ 10 - $\pm 10 \mu\text{m}$	S - version S (cable outlet) C - version C (connector outlet)	01 - 1m 02 - 2m 03 - 3m ... CP01 - 1m armoured CP02 - 2m armoured CP03 - 3m armoured ...	W - without connector B12 - round, 12 pins C9 - round, 9 pins C12 - round, 12 pins D9 - flat, 9 pins D15 - flat, 15 pins RS10 - round, 10 pins ONC - round, 10 pins	M - with mounting spar W - without mounting spar
ORDER EXAMPLE: 1) L18-F10-0420-L1/100-05-S-03/W-W							

# PHOTOELECTRIC LINEAR ENCODER

# L18B



Photoelectric linear encoder L18B is able to have the measuring length of up to 3.240 mm, maximum accuracy of  $\pm 5 \mu\text{m}$  to any meter within the ML and grating periods of  $\pm 20 \mu\text{m}$ ,  $\pm 40 \mu\text{m}$ .

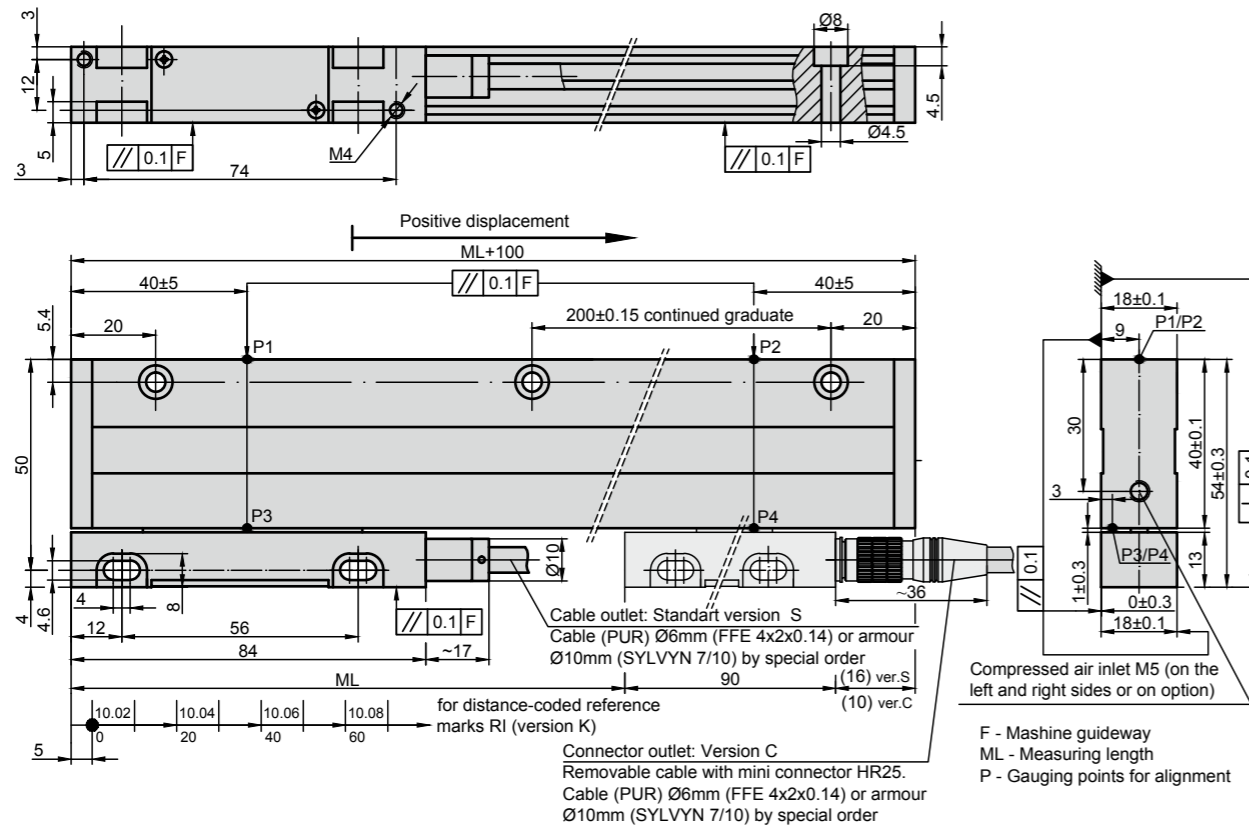

## MECHANICAL DATA

Measuring lengths (ML), mm	70; 120; 170; 220; 270; 320; 370; 420; 470; 520; 620; 720; 820; 920; 1020; 1140; 1240; 1340; 1440; 1540; 1640; 1740; 1840; 1940; 2040; 2140; 2240; 2340; 2440; 2540; 2640; 2740; 2840; 2940; 3040; 3140; 3240 (other intermediate lengths on request)	Max. traversing speed: -when interpolation factor is 1,2,5,10 -when interpolation factor is 25 -when interpolation factor is 50	1 m/s 0.5 m/s 0.4 m/s
Accuracy grades to any metre within the ML (at 20°C): - for ML 70 to 2040 - for ML 2040 to 3240	$\pm 10$ ; $\pm 5 \mu\text{m}$ $\pm 10 \mu\text{m}$	Required moving force with sealing lips	< 3 N
Grating period	20 $\mu\text{m}$ ; 40 $\mu\text{m}$ (optional)	Protection (IEC 529) -without compressed air -with compressed air (optional)	IP53 IP64
Reference marks (RI): -standard for ML $\leq 1020$ mm -standard for ML > 1140 mm -optional	35mm from both ends of ML 45mm from both ends of ML one RI at any location, or two or more RIs separated by distances of $n \times 50$ mm or distance-coded	Weight	0.4 kg + 1.0 kg/m
		Operating temperature	0...+50°C
		Storage temperature	-20...+70°C
		Permissible vibration (40 to 2000 Hz)	$\leq 30 \text{ m/s}^2$
		Permissible shock (11 ms)	$\leq 100 \text{ m/s}^2$

## ELECTRICAL DATA

Version	L18B-A $\sim 11 \mu\text{App}$	L18B-AV $\sim 1 \text{ Vpp}$	L18B-F $\square$ TTL
Power supply	+5 V $\pm 5\%$ / < 90 mA	+5 V $\pm 5\%$ < 120 mA	+5 V $\pm 5\%$ / < 120 mA
Light source	LED	LED	LED
Resolution	Depends on external subdividing electronics	Depends on external subdividing electronics	5; 1; 2.5; 0.5; 0.2; 0.1 $\mu\text{m}$ (after 4-fold dividing in subsequent electronics)
Incremental signals	Two sinusoidal $I_1$ and $I_2$ Amplitude at 1 k $\Omega$ load: - $I_1 = 7-16 \mu\text{A}$ - $I_2 = 7-16 \mu\text{A}$	Differential sine +A/-A and +B/-B Amplitude at 120 $\Omega$ load: - A = 0.6-1.2 V - B = 0.6-1.2 V	Differential square-wave $U1/\overline{U1}$ and $U2/\overline{U2}$ . Signal levels at 20 mA load current: - low (logic "0") $\leq 0.5 \text{ V}$ - high (logic "1") $\geq 2.4 \text{ V}$
Reference signal	Quasi-triangular $I_0$ . Signal magnitude at 1 k $\Omega$ load: - $I_0 = 2-8 \mu\text{A}$	Quasi-triangular +R and its complementary -R. Signals magnitude at 120 $\Omega$ load - R = 0.2-0.8 V	One differential square-wave $U0/\overline{U0}$ per revolution. Signal levels at 20 mA load current: - low (logic "0") < 0.5 V - high (logic "1") > 2.4 V
Maximum operating frequency	50 kHz	50 kHz	50x kHz, when interpolation factor is 1, 2, 5, 10 1000 kHz when interpolation factor is 25, 50
Direction of signals	$I_2$ lags $I_1$ at reading head displacement from left to right	B+ lags A+ at reading head displacement from left to right	$U2$ lags $U1$ at reading head displacement from left to right
Standard cable length	3 m, without connector	3 m, without connector	3 m, without connector
Maximum cable length	5 m	25 m	25 m
Output signals			

Note: If cable extension is used the power supply conductor section should not be smaller than 0.5 mm<sup>2</sup>.

## ACCESSORIES

CONNECTORS FOR CABLE	B12 12-pin round connector	C9 9-pin round connector	C12 12-pin round connector	D9 9-pin flat connector	D15 15-pin flat connector	RS10 10-pin round connector	ONC 10-pin round connector	HR25 8-pins round mini connector
DIGITAL READOUT DEVICES	CS3000					CS5500		
EXTERNAL INTERPOLATOR	NK							

## ORDER FORM

L18B	X1	X2	X3	X4	X5	X6/X7
Output signals And resolution (X1):	Measuring length (X2):	Reference marks (X3):	Accuracy (X4):	Cable or Connector Outlet (X5):	Cable length (X6):	Connector type (X7):
A - Sinusoidal AV - Sinusoidal F01 - TTL 0.1 $\mu\text{m}$ F02 - TTL 0.2 $\mu\text{m}$ F10 - TTL 1.0 $\mu\text{m}$ F25 - TTL 2.5 $\mu\text{m}$ F50 - TTL 5.0 $\mu\text{m}$	0070 - 70 mm 0520 - 520 mm ... 3240 - 3240 mm	N - none RI S - standard M - every 50 mm K - distance coded Ln/XXX - n RI with 50-fold steps /XXX distance of the first RI from the beginning of ML, mm	05 - $\pm 5 \mu\text{m}$ 10 - $\pm 10 \mu\text{m}$	S - version S (cable outlet) C - version C (connector outlet)	01 - 1m 02 - 2m 03 - 3m ... CP01 - 1m armoured CP02 - 2m armoured CP03 - 3m armoured ...	W - without connector B12 - round, 12 pins C9 - round, 9 pins C12 - round, 12 pins D9 - flat, 9 pins D15 - flat, 15 pins RS10 - round, 10 pins ONC - round, 10 pins
ORDER EXAMPLE: 1) L18B-F10-2440-S-05-C-CP03/W						

# PHOTOELECTRIC LINEAR ENCODER

# L18T



Photoelectric linear encoder L18T does not vary much from L18 series and retains almost identical parameters. However, it has a different housing fixation and more stable thermal behavior.

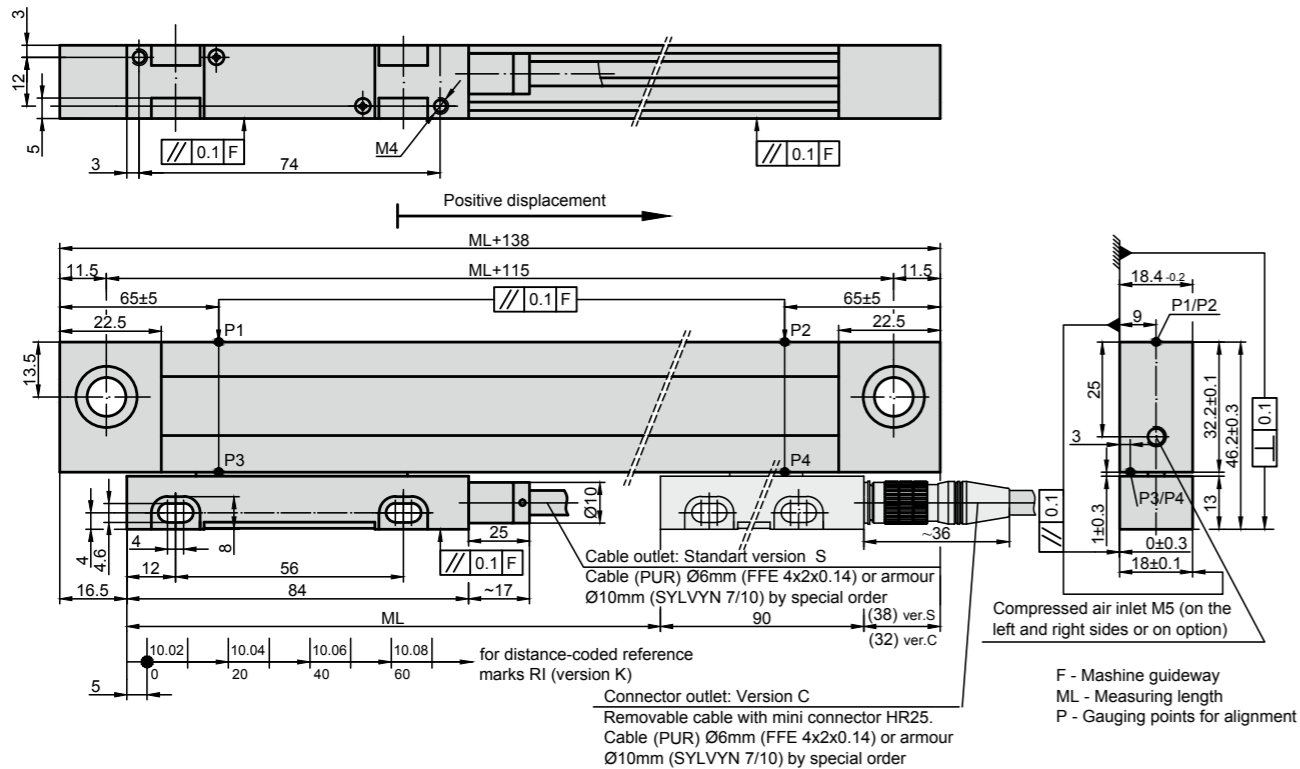

## MECHANICAL DATA

Measuring lengths (ML), mm	70; 120; 170; 220; 270; 320; 370; 420; 470; 520; 620; 720; 820; 920; 1020; 1140; 1240; (other intermediate lengths on request)	Required moving force with sealing lips	< 3 N
Accuracy grades to any metre within the ML (at 20°C):	±10; ±5; ±3 µm (optional)	Protection (IEC 529) -without compressed air -with compressed air (optional)	IP53 IP64
Grating period	20 µm; 40 µm (optional)	Weight	0.4 kg + 0.8 kg/m
Reference marks (RI): -standard for ML ≤ 1020 mm -standard for ML > 1140 mm -optional	35mm from both ends of ML 45mm from both ends of ML one RI at any location, or two or more RI's separated by distances of n x 50 mm or distance-coded	Operating temperature	0...+50°C
Max. traversing speed: -when interpolation factor is 1,2,5,10 -when interpolation factor is 25 -when interpolation factor is 50	1 m/s 0.5 m/s 0.4 m/s	Storage temperature	-20...+70°C
		Permissible vibration (40 to 2000 Hz)	≤ 30 m/s <sup>2</sup>
		Permissible shock (11 ms)	≤ 100 m/s <sup>2</sup>

## ELECTRICAL DATA

Version	L18T-A ~ 11 µApp	L18T-AV ~ 1 Vpp	L18T-F TTL
Power supply	+5V ± 5% / < 90 mA	+5V ± 5% < 120 mA	+5V ± 5% / < 120 mA
Light source	LED	LED	LED
Resolution	Depends on external subdividing electronics	Depends on external subdividing electronics	5; 2.5; 1; 0.5; 0.2; 0.1 µm (after 4-fold dividing in subsequent electronics)
Incremental signals	Two sinusoidal I <sub>1</sub> and I <sub>2</sub> Amplitude at 1 kΩ load: - I <sub>1</sub> = 7-16 µA - I <sub>2</sub> = 7-16 µA	Differential sine +A/-A and +B/-B Amplitude at 120 Ω load: - A = 0.6-1.2 V - B = 0.6-1.2 V	Differential square-wave U1/U1 and U2/U2. Signal levels at 20 mA load current: - low (logic "0") ≤ 0.5 V - high (logic "1") ≥ 2.4 V
Reference signal	One quasi-triangular I <sub>0</sub> peak per revolution. Signal magnitude at 1 kΩ load: - I <sub>0</sub> = 2-8 µA (usable component)	One quasi-triangular +R and its complementary -R per revolution. Signals magnitude at 120 Ω load - R = 0.2-0.8 V (usable component)	One differential square-wave U0/U0 per revolution. Signal levels at 20 mA load current: - low (logic "0") < 0.5 V - high (logic "1") > 2.4 V
Maximum operating frequency	50 kHz	50 kHz	50xk kHz, when interpolation factor is 1, 2, 5, 10 1000 kHz when interpolation factor is 25, 50
Direction of signals	I <sub>2</sub> lags I <sub>1</sub> at reading head displacement from left to right	B+ lags A+ at reading head displacement from left to right	U2 lags U1 at reading head displacement from left to right
Standard cable length	3 m, without connector	3 m, without connector	3 m, without connector
Maximum cable length	5 m	25 m	25 m

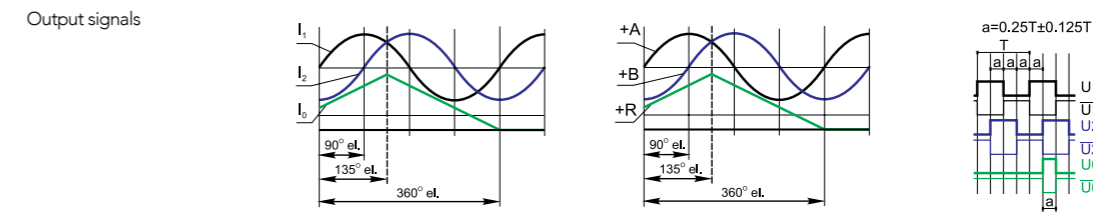

Note: If cable extension is used the power supply conductor section should not be smaller than 0.5 mm<sup>2</sup>.

## ACCESSORIES

CONNECTORS FOR CABLE	B12 12-pin round connector	C9 9-pin round connector	C12 12-pin round connector	D9 9-pin flat connector	D15 15-pin flat connector	RS10 10-pin round connector	ONC 10-pin round connector	HR25 8-pins round mini connector
DIGITAL READOUT DEVICES	CS3000				CS5500			
EXTERNAL INTERPOLATOR	NK							

## ORDER FORM

L18T	X1	X2	X3	X4	X5	X6/X7
Output signals And resolution (X1):	Measuring length (X2):	Reference marks (X3):	Accuracy (X4):	Cable or Connector Outlet (X5):	Cable length (X6):	Connector type (X7):
A - Sinusoidal AV - Sinusoidal F01 - TTL 0.1µm F02 - TTL 0.2µm F05 - TTL 0.5µm F10 - TTL 1.0µm F25 - TTL 2.5µm F50 - TTL 5.0µm	0070 - 70 mm 0520 - 520 mm ... 1240 - 1240 mm	N - none RI S - standard M - every 50 mm K - distance coded Ln/XXX - n RI with 50-fold steps /XXX distance of the first RI from the beginning of ML, mm	05 - ±5 µm 10 - ±10 µm	S - version S (cable outlet) C - version C (connector outlet)	01 - 1m 02 - 2m 03 - 3m ... CP01 - 1m armoured CP02 - 2m armoured CP03 - 3m armoured ...	W - without connector B12 - round, 12 pins C9 - round, 9 pins C12 - round, 12 pins D9 - flat, 9 pins D15 - flat, 15 pins RS10 - round, 10 pins ONC - round, 10 pins

ORDER EXAMPLE: 1) L18T-A-1240-K-05-C-03/C9

# PHOTOELECTRIC LINEAR ENCODER

# L23

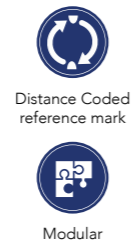

Distance Coded reference mark



Modular



Photoelectric modular linear encoder L23 can have up to 20.000 mm measuring length or even more on special order and is able reach up to  $\pm 5 \mu\text{m}$  accuracy.

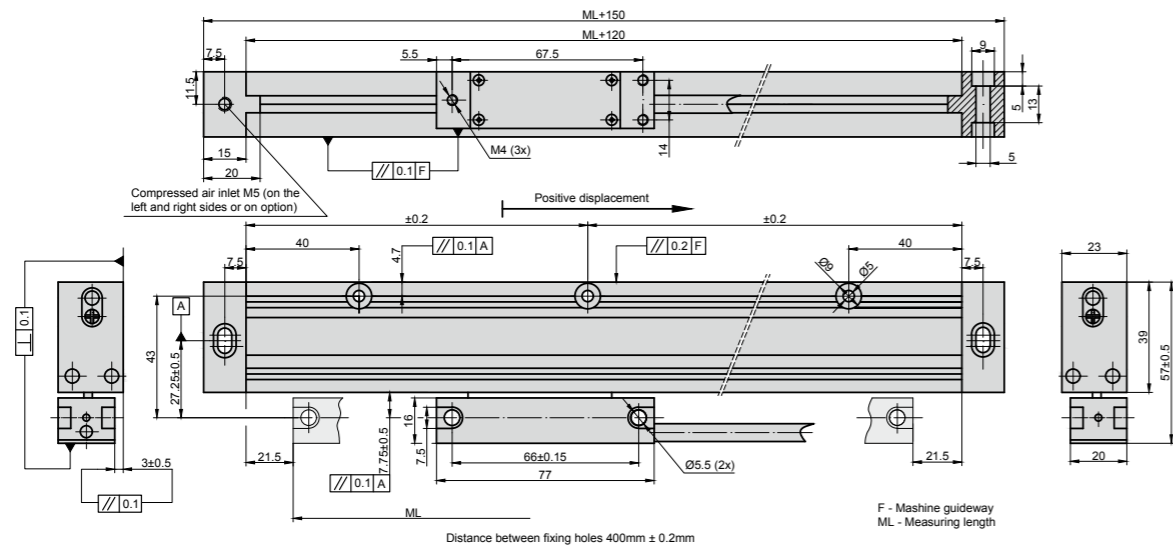

## MOUNTING REQUIREMENTS

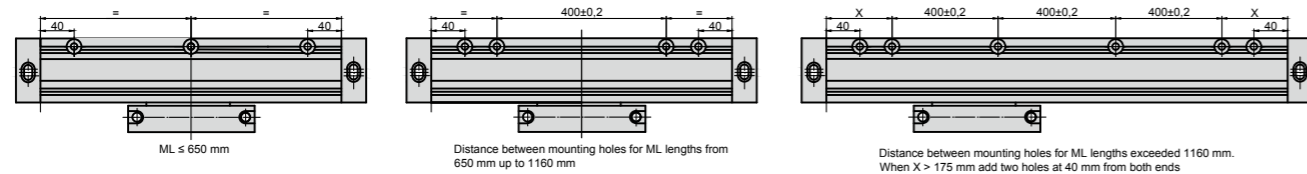

## MECHANICAL DATA

Measuring lengths (ML), mm	250, 300, 350, 400, 450, 500...20000 (in modular version for ML over 6500 mm or for lower ML on request)	Protection (IEC 529)	-without compressed air -with compressed air	IP54 IP64
Accuracy grades to any metre within the ML (at 20°C)	±5	Weight	0.4 kg + 1.3 kg/m	
Max. traversing speed: - when resolution is 100, 50, 10, 5, 2, 1 μm - when resolution is 0.2 μm - when resolution is 0.1 μm	120 m/min 60 m/min 30 m/min	Operating temperature	0...+50°C	
Reference marks (RI): - N - M - P	without reference mark; every 30 mm; RI number and place on option	Storage temperature	-20...+70°C	
Coefficient of thermal expansion	10.6x10 <sup>-6</sup> °C	Permissible vibration (10...2000 Hz)	≤ 100 m/s <sup>2</sup>	
Required moving force	< 4 N	Permissible shock (11 ms)	≤ 150 m/s <sup>2</sup>	
		Coefficient of thermal expansion	10.6x10 <sup>-6</sup> °C	
		Max. acceleration	30 m/s <sup>2</sup>	
		Relative humidity	20...80% (not condensed)	

## ELECTRICAL DATA

Version	L23-F □□ TTL
Supply voltage (U <sub>s</sub> )	+5V±5%/ 140 mA; +(10...28V)±5%
Light source	LED
Resolution	100, 50; 10; 5; 1; 0.5 μm (after 4-fold in subsequent electronics)
Incremental signals	Differential square-wave U1/U1 and U2/U2
Reference signal	Differential square-wave U0/U0
Signal levels at load current 20 mA:	- low (logic "0") < 0.5 V at U <sub>p</sub> =+5V - high (logic "1") > 2.4 V at U <sub>p</sub> =+5V - low (logic "0") < 1.5 V at U <sub>p</sub> =+12V (HTL) - high (logic "1") > (U <sub>p</sub> -2) V at U <sub>p</sub> =+12V (HTL)
Direction of signals	U2 lags U1 (displacement from left to right and head position down)
Standard cable length	4 m armoured, without connector
Maximum cable length	100 m
Output signals	

Note: If cable extension is used the power supply conductor section should not be smaller than 0.35 mm<sup>2</sup>.

## ACCESSORIES

CONNECTORS FOR CABLE	B12	C9	C12	D9	D15	RS10	ONC
	12-pin round connector	9-pin round connector	12-pin round connector	9-pin flat connector	15-pin flat connector	10-pin round connector	10-pin round connector
DIGITAL READOUT DEVICES	CS3000				CS5500		

## ORDER FORM

Resolution (X1):	Measuring length (X2):	Reference marks (X3):	Supply Voltage (X4):	Compressed air (X5):	Cable (armoured) length (X6):	Connector type (X7):
<b>F01</b> - TTL 0.1μm <b>F02</b> - TTL 0.2μm <b>F05</b> - TTL 0.5μm <b>F10</b> - TTL 1μm <b>F50</b> - TTL 5μm <b>F100</b> - TTL 10μm <b>F500</b> - TTL 50μm <b>F1000</b> - TTL 100μm	<b>0250</b> - 250mm <b>0500</b> - 500mm ... <b>20000</b> - 20000mm ... - (on request)	<b>N</b> - none RI <b>M</b> - every 30mm <b>P</b> - RI number and place on option	<b>05V</b> - +5V <b>28V</b> - +(10...28V)	<b>0</b> - without compressed air <b>1</b> - with compressed air	<b>01</b> - 1m <b>02</b> - 2m <b>03</b> - 3m <b>04</b> - 4m (standard) ...	<b>W</b> - without connector <b>B12</b> - round, 12 pins <b>C9</b> - round, 9 pins <b>C12</b> - round, 12 pins <b>D9</b> - flat, 9 pins <b>D15</b> - flat, 15 pins <b>RS10</b> - round, 10 pins <b>ONC</b> - round, 10 pins

ORDER EXAMPLE: 1) L23-F100-16000-N-05V-0-04/C12



# PHOTOELECTRIC LINEAR ENCODER

# LK24



SSI protocol



Absolute Encoder



BiSS protocol



Analog output signals



Photoelectric absolute linear encoder LK24 has measuring length of up to 3.240 mm depending on customer demand, uses SSI or BiSS

serial interface and produces up to  $\pm 3 \mu\text{m}$  accuracy. The encoder can have an additional 1Vpp incremental track.

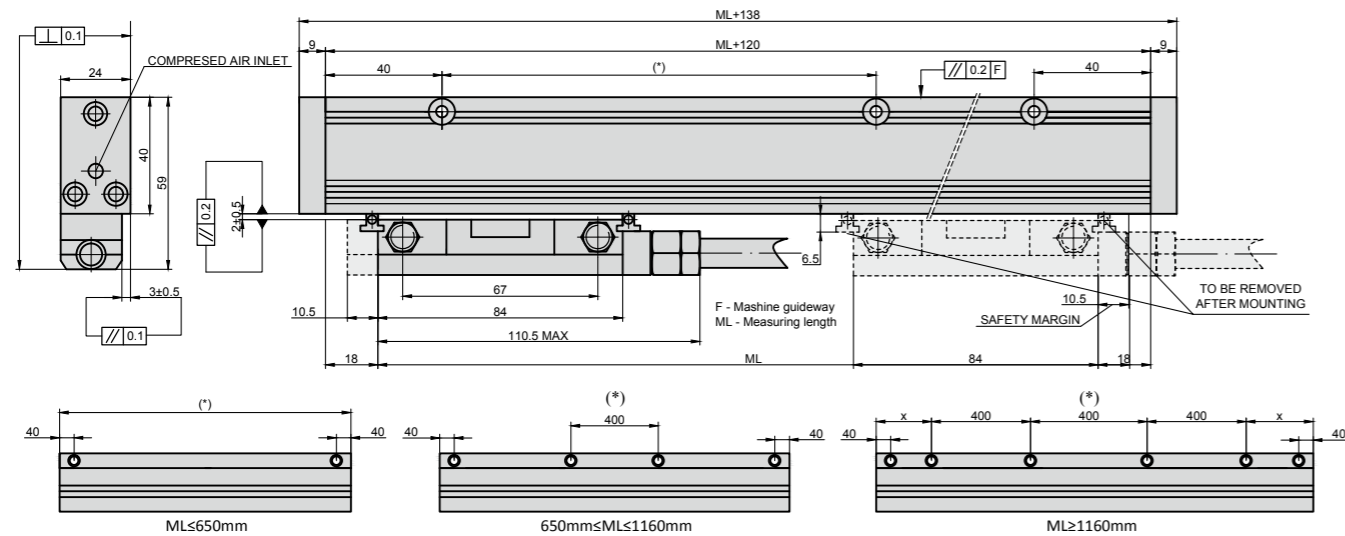

(\*) Add holes at 40mm from cut ends, when the first hole at constant step is at a distance X>175mm.

## MECHANICAL DATA

Measuring lengths (ML), mm	70, 120, 170, 220, 270, 320, 370, 420, 470, 520, 570, 620, 720, 770, 820, 920, 1020, 1140, 1240, 1340, 1440, 1540, 1640, 1740, 1840, 2040, 2240, 2440, 2640, 2840, 3040, 3240	Current consumption with load	max 340 mA (with R=120Ω)
Incremental signal	sine wave 1 Vpp (optional)	Protection (EN 60529)	IP54 IP64
Resolution 1Vpp	up to 0.1 μm (depending on CNC division factor)	Operating temperature	0...+50°C
Serial interface	SSI or BiSS	Storage temperature	-20...+70°C
Resolution absolute measure	1 μm, 0.1 μm	Permissible humidity (non condensed)	20...80 %
Accuracy grades to any metre within the ML (at 20°C)	± 3 μm	Permissible vibration (55...2000 Hz)	≤ 100 m/s <sup>2</sup>
Grating period (T)	20 μm	Permissible shock (11 ms)	≤ 150 m/s <sup>2</sup>
Max. traversing speed:	2 m/s	Weight	0.44 kg +1,3kg/m
Max. acceleration	30 m/s	Standard cable length/max. cable length	2.0/20.0 (50 m if power supply is min. 5V)
Required moving force	≤2.5N	Electrical protections	from inversion of power supply polarity; from short circuit on output port
Power supply	+5V ± 5%		

## OUTPUT SIGNALS

SSI VERSION

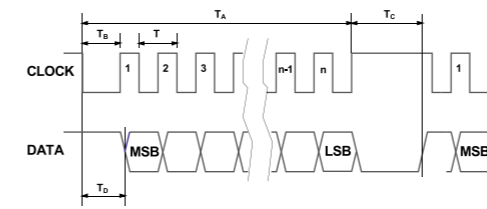

Interface	SSI Binary – Gray
Signals level	EIA RS 485
Clock frequency	0.1 - 1.2 MHz
n	Position bit
T <sub>c</sub>	10 - 20 μs

BISS C VERSION

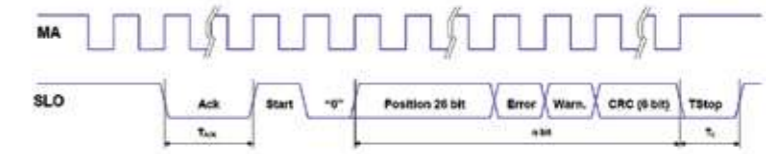

Interface	BiSS C unidirectional
Signals level	EIA RS 485
Clock frequency	0.1 - 4 MHz
n	26 + 2 + 6 bit
T <sub>c</sub>	12 - 20 μs

## CABLE

SERIAL OUTPUT

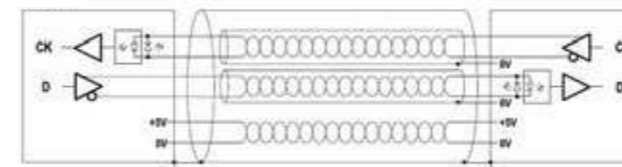

Encoder is supplied with flexible cable, which is consisted of shielded twisted pairs of wires (for informational signals SSI-BISS).

**Cable for serial output:**

- 6-wire shielded cable, Ø=7 mm, PVC external sheath, with low friction coefficient, oil-resistant, suitable for continuous movements
- conductors section: power supply 0.25 mm<sup>2</sup>, signals 0.25 mm<sup>2</sup>
- cable's bending radius should not be lower than 35 mm.

ANALOG OUTPUT + SERIAL OUTPUT

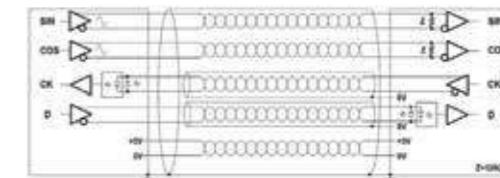

**In case of cable extension, it is necessary to guarantee:**

- electrical connection between the body of the connectors and the cables shield;
- minimum power supply voltage of 5 V to the head.

**Cable for analog output + serial output:**

- 10-wire shielded cable, Ø=7.1 mm, PUR external sheath.
- conductors section: power supply 0.35 mm<sup>2</sup>, signals 0.10 mm<sup>2</sup>
- cable's bending radius should not be lower than 45 mm.

## ACCESSORIES

CONNECTORS FOR CABLE	B12	C9	C12	D9	D15
	12-pin round connector	9-pin round connector	12-pin round connector	9-pin flat connector	15-pin flat connector

## ORDER FORM

<b>LK24</b>	-	<b>X1</b>	-	<b>X2</b>	-	<b>X3</b>	-	<b>X4</b>	-	<b>X5/X6</b>
Resolution (X1):	Measuring length (X2):	Output signals (X3):	Incremental signals (X4):	Cable length (X5):	Connector type (X6):					
<b>F01</b> - 0.1 μm <b>F10</b> - 1.0 μm	<b>0070</b> - 70 mm <b>0520</b> - 520 mm <b>3240</b> - 3240 mm	<b>S1</b> - SSI binary <b>S2</b> - SSI binary+even parity <b>S3</b> - SSI binary+odd parity <b>S4</b> - SSI binary+error <b>S5</b> - SSI binary+even+parity+error <b>S6</b> - SSI binary+odd parity+error <b>S7</b> - SSI Gray <b>B1</b> - BiSS binary	<b>W</b> - without incremental signals <b>V</b> - 1Vpp	<b>01</b> - 1m <b>02</b> - 2m <b>03</b> - 3m ...	<b>W</b> - without connector <b>B12</b> - round, 12 pins <b>C12</b> - round, 12 pins <b>C9</b> - round, 9 pins <b>D9</b> - flat, 9 pins <b>D15</b> - flat, 15 pins					
ORDER EXAMPLE: 1) LK24-F01-0070-S1-W-01/W										

# PHOTOELECTRIC LINEAR ENCODER

# L35



Distance Coded reference mark



Analog output signals



High vibration resistance



Photoelectric linear encoder L35 is an incremental linear displacement measuring device that has up to 3.240 mm measuring length, up to  $\pm 3 \mu\text{m}$  accuracy grades to any meter within the ML depending

on measuring length demanded. L35 series is more vibration resistant than L18 series of encoders.

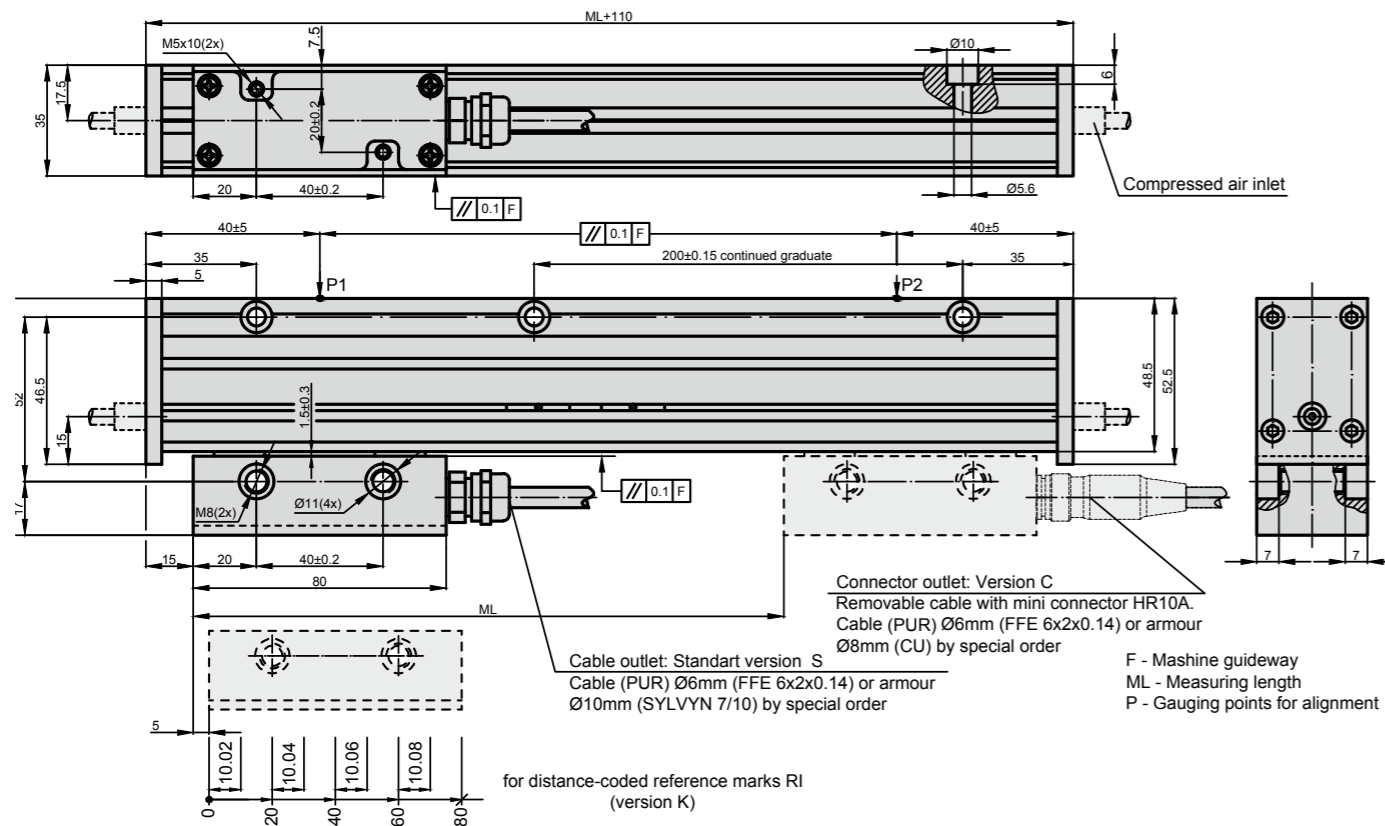

## MECHANICAL DATA

Measuring lengths (ML), mm	170; 220; 270; 320; 370; 420; 470; 520; 620; 720; 820; 920; 1020; 1140; 1240; 1340; 1440; 1540; 1640; 1740; 1840; 1940; 2040; 2140; 2240; 2340; 2440; 2540; 2640; 2740; 2840; 2940; 3040; 3140; 3240 (other intermediate lengths on request)	- distance-coded - selection by magnets	see drawing standard - one magnet (RI) in ML middle
Accuracy grades to any metre within the ML (at 20°C): - for ML from 170 up to 2040 mm - for ML from 2040 up to 3240 mm	$\pm 5; \pm 3$ $\pm 10 \mu\text{m}$	Max. traversing speed: -when interpolation factor is 1,2,5,10 -when interpolation factor is 25 -when interpolation factor is 50	1 m/s (shortly 2 m/s) 0.5 m/s 0.4 m/s
Grating period	20 $\mu\text{m}$ ; 40 $\mu\text{m}$	Required moving force with sealing lips	< 5 N
Reference marks (RI): -standard for ML $\leq 1020$ mm -standard for ML > 1140 mm -optional	35mm from both ends of ML 45mm from both ends of ML one RI at any location, two or more RI's separated by distances of (n x 50 mm)	Protection (IEC 529): -without compressed air -with compressed air (optional)	IP54 IP64
		Weight	0.4 kg + 2.8 kg/m
		Operating temperature	0...+50°C
		Storage temperature	-20...+70°C
		Permissible vibration (40 to 2000 Hz)	$\leq 150 \text{ m/s}^2$
		Permissible shock (11 ms)	$\leq 300 \text{ m/s}^2$

## ELECTRICAL DATA

Version	L35TA $\sim 11 \mu\text{App}$	L35-AV $\sim 1 \text{ Vpp}$	L35-F $\square$ TTL; $\square$ HTL
Power supply	+5 V $\pm 5\%$ / < 90 mA	+5 V $\pm 5\%$ < 90 mA	+5 V $\pm 5\%$ / < 120 mA; +12V $\pm 5\%$ / < 130mA
Light source	LED	LED	LED
Resolution	Depends on external subdividing electronics	Depends on external subdividing electronics	5; 2.5; 1; 0.5; 0.2; 0.1 $\mu\text{m}$ (after 4-fold dividing in subsequent electronics)
Incremental signals	Two sinusoidal I1 and I2 Amplitude at 1 k $\Omega$ load: - I1 = 7-16 $\mu\text{A}$ - I2 = 7-16 $\mu\text{A}$	Differential sine +A/-A and +B/-B Amplitude at 120 $\Omega$ load: - A = 0.6-1.2 V - B = 0.6-1.2 V	Differential square-wave U1/U1 and U2/U2. Signal levels at 20 mA load current: - low (logic "0") $\leq 0.5 \text{ V}$ at Up=+5V - high (logic "1") $\geq 2.4 \text{ V}$ at Up=+5V - low (logic "0") $\leq 1.5 \text{ V}$ at Up=+12V (HTL) - high (logic "1") $\geq (\text{Up}-2) \text{ V}$ at Up=+12V (HTL)
Reference signal	One quasi-triangular I <sub>0</sub> Signal magnitude at 1 k $\Omega$ load: - I <sub>0</sub> = 2-8 $\mu\text{A}$ (usable component)	One quasi-triangular +R and its complementary -R per revolution. Signals magnitude at 120 $\Omega$ load - R = 0.2-0.8 V (usable component)	One differential square-wave U0/U0 per revolution. Signal levels at 20 mA load current: - low (logic "0") $\leq 0.5 \text{ V}$ at Up=+5V - high (logic "1") $\geq 2.4 \text{ V}$ at Up=+5V - low (logic "0") $\leq 1.5 \text{ V}$ at Up=+12V (HTL) - high (logic "1") $\geq (\text{Up}-2) \text{ V}$ at Up=+12V (HTL)
Maximum operating frequency	50 kHz (v=1 m/s) 100 kHz (v=2 m/s shortly)	50 kHz (v=1 m/s) 100 kHz (v=2 m/s shortly)	(50 x k) kHz for k=1, 2, 5, 10 1000 kHz for k= 25, 50, where k- interpolation factor
Direction of signals (displacement from left to right)	I <sub>2</sub> lags I <sub>1</sub>	B+ lags A+	U <sub>2</sub> lags U <sub>1</sub>
Standard cable length	3 m, without connector	3 m, without connector	3 m, without connector
Maximum cable length	5 m	25 m	25 m
Output signals			

Note: If cable extension is used the power supply conductor section should not be smaller than 0.5 mm<sup>2</sup>.

## ACCESSORIES

CONNECTORS FOR CABLE	B12	C9	C12	D9	D15	RS10	ONC	HR10A
	12-pin round connector	9-pin round connector	12-pin round connector	9-pin flat connector	15-pin flat connector	10-pin round connector	10-pin round connector	12-pins round mini connector
DIGITAL READOUT DEVICES	CS3000						CS5500	
EXTERNAL INTERPOLATOR	NK							

## ORDER FORM

L35	- X1 - X2 - X3 - X4 - X5 - X6/X7					
Output signals And resolution (X1):	Measuring length (X2):	Reference Marks (X3):	Accuracy (X4):	Cable or Connector Outlet (X5):	Cable length (X6):	Connector type (X7):
A - Sinusoidal AV - Sinusoidal F01 - TTL / HTL 0.1 $\mu\text{m}$ F02 - TTL / HTL 0.2 $\mu\text{m}$ F05 - TTL / HTL 0.5 $\mu\text{m}$ F10 - TTL / HTL 1.0 $\mu\text{m}$ F25 - TTL / HTL 2.5 $\mu\text{m}$ F50 - TTL / HTL 5.0 $\mu\text{m}$	0070 - 70 mm 0520 - 520 mm ... 3240 - 3240 mm	N - none RI S - standard M - every 50mm K - distance-coded Ln/XXX - n RI with 50-fold steps /XXX distance of the first RI from the beginning of ML, mm O - selection by magnets (standard - one magnet (RI) in ML middle)	10 - $\pm 10 \mu\text{m}^*$ 05 - $\pm 5 \mu\text{m}^*$ 03 - $\pm 3 \mu\text{m}^*$ (optional)  *depends on length	S - version S (cable outlet) C - version C (connector outlet)	01 - 1m 02 - 2m 03 - 3m  CP01 - 1m armoured CP02 - 2m armoured CP03 - 3m armoured ...	W - without connector B12 - round, 12 pins C9 - round, 9 pins C12 - round, 12 pins D9 - flat, 9 pins D15 - flat, 15 pins RS10 - round, 10 pins ONC - round, 10 pins
ORDER EXAMPLE: 1) L35-F05-2040-O-10-C-CP03/C12						

PHOTOELECTRIC LINEAR ENCODER

# L35T



Distance Coded reference mark



Analog output signals



High vibration resistance



Photoelectric linear encoder L35T is very similar encoder to L35 series, but has different mounting parameters. It can also have up to

3.240 mm measuring length and is more vibration resistant than L18 series.

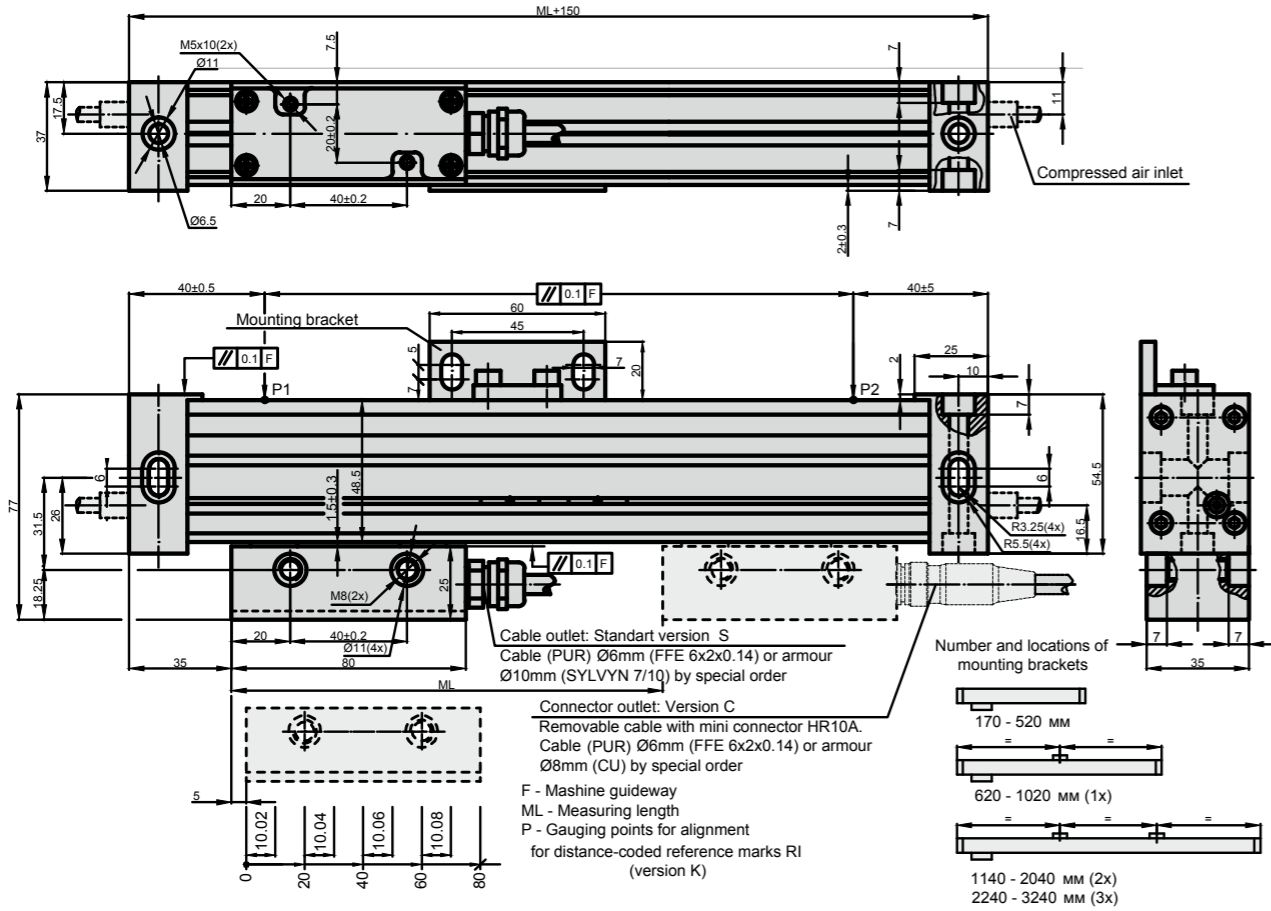

## MECHANICAL DATA

Measuring lengths (ML), mm	170; 220; 270; 320; 370; 420; 470; 520; 620; 720; 820; 920; 1020; 1140; 1240; 1340; 1440; 1540; 1640; 1740; 1840; 1940; 2040; 2140; 2240; 2340; 2440; 2540; 2640; 2740; 2840; 2940; 3040; 3140; 3240 (other intermediate lengths on request)	- distance-coded - selection by magnets	see drawing standard - one magnet (RI) in ML middle
Accuracy grades to any metre within the ML (at 20°C): - for ML from 170 up to 2040 mm - or ML from 2040 up to 3240 mm	±5; ±3 ±10 µm	Max. traversing speed: - when interpolation factor is 1,2,5,10 - when interpolation factor is 25 - when interpolation factor is 50	1 m/s (shortly 2 m/s) 0.5 m/s 0.4 m/s
Grating period	20 µm; 40 µm	Required moving force with sealing lips	< 5 N
Reference marks (RI): - standard for ML ≤ 1020 mm - standard for ML > 1140 mm - optional	35mm from both ends of ML 45mm from both ends of ML one RI at any location, two or more RI's separated by distances of (n x 50 mm)	Protection (IEC 529): - without compressed air - with compressed air (optional)	IP54 IP64
		Weight	0.4 kg + 2.8 kg/m
		Operating temperature	0...+50°C
		Storage temperature	-20...+70°C
		Permissible vibration (40 to 2000 Hz)	≤ 150 m/s <sup>2</sup>
		Permissible shock (11 ms)	≤ 300 m/s <sup>2</sup>

## ELECTRICAL DATA

Version	L35T-A ~ 11 µApp	L35T-AV ~ 1 Vpp	L35T-F TTL; HTL
Power supply	+5 V ± 5% / < 90 mA	+5 V ± 5% / < 90 mA	+5 V ± 5% / < 120 mA; +12V±5% / < 130mA
Light source	LED	LED	LED
Resolution	Depends on external subdividing electronics	Depends on external subdividing electronics	5; 2.5; 1; 0.5; 0.2; 0.1 µm (after 4-fold dividing in subsequent electronics)
Incremental signals	Two sinusoidal I1 and I2 Amplitude at 1 kΩ load: - I1 = 7-16 µA - I2 = 7-16 µA	Differential sine +A/-A and +B/-B Amplitude at 120 Ω load: - A = 0.6-1.2 V - B = 0.6-1.2 V	Differential square-wave U1/U1 and U2/U2. Signal levels at 20 mA load current: - low (logic "0") ≤ 0.5 V at Up=+5V - high (logic "1") ≥ 2.4 V at Up=+5V - low (logic "0") ≤ 1.5 V at Up=+12V (HTL) - high (logic "1") ≥ (Up-2) V at Up=+12V (HTL)
Reference signal	One quasi-triangular I <sub>0</sub> . Signal magnitude at 1 kΩ load: - I <sub>0</sub> = 2-8 µA (usable component)	One quasi-triangular +R and its complementary -R per revolution. Signals magnitude at 120 Ω load - R = 0.2-0.8 V (usable component)	One differential square-wave U0/U0 per revolution. Signal levels at 20 mA load current: - low (logic "0") ≤ 0.5 V at Up=+5V - high (logic "1") ≥ 2.4 V at Up=+5V - low (logic "0") ≤ 1.5 V at Up=+12V (HTL) - high (logic "1") ≥ (Up-2) V at Up=+12V (HTL)
Maximum operating frequency	50 kHz (v=1 m/s) 100 kHz (v=2 m/s shortly)	50 kHz (v=1 m/s) 100 kHz (v=2 m/s shortly)	(50 x k) kHz for k=1, 2, 5, 10 1000 kHz for k= 25, 50, where k- interpolation factor
Direction of signals (displacement from left to right)	I <sub>2</sub> lags I <sub>1</sub>	B+ lags A+	U <sub>2</sub> lags U <sub>1</sub>
Standard cable length	3 m, without connector	3 m, without connector	3 m, without connector
Maximum cable length	5 m	25 m	25 m
Output signals			

Note: If cable extension is used the power supply conductor section should not be smaller than 0.5 mm<sup>2</sup>.

## ACCESSORIES

CONNECTORS FOR CABLE	B12	C9	C12	D9	D15	RS10	ONC	HR10A
	12-pin round connector	9-pin round connector	12-pin round connector	9-pin flat connector	15-pin flat connector	10-pin round connector	10-pin round connector	12-pins round mini connector
DIGITAL READOUT DEVICES	CS3000						CS5500	
EXTERNAL INTERPOLATOR	NK							

## ORDER FORM

L35T	X1	X2	X3	X4	X5	X6/X7
Output signals And resolution (X1):	Measuring length (X2):	Reference Marks (X3):	Accuracy (X4):	Cable or Connector Outlet (X5):	Cable length (X6):	Connector type (X7):
<b>A</b> - Sinusoidal <b>AV</b> - Sinusoidal <b>F01</b> - TTL / HTL 0.1µm <b>F02</b> - TTL / HTL 0.2µm <b>F05</b> - TTL / HTL 0.5µm <b>F10</b> - TTL / HTL 1.0µm <b>F25</b> - TTL / HTL 2.5µm <b>F50</b> - TTL / HTL 5.0µm	<b>0070</b> - 70 mm <b>0520</b> - 520 mm ... <b>3240</b> - 3240 mm	<b>N</b> - none RI <b>S</b> - standard <b>M</b> - every 50mm <b>K</b> - distance-coded <b>Ln/XXX</b> - n RI with 50-fold steps /XXX distance of the first RI from the beginning of ML, mm <b>O</b> - selection by magnets (standard - one magnet (RI) in ML middle)	<b>10</b> - ±10 µm* <b>05</b> - ±5 µm* <b>03</b> - ±3 µm* (optional) *depends on length	<b>S</b> - version S (cable outlet) <b>C</b> - version C (connector outlet)	<b>01</b> - 1m <b>02</b> - 2m <b>03</b> - 3m ... <b>CP01</b> - 1m armoured <b>CP02</b> - 2m armoured <b>CP03</b> - 3m armoured ...	<b>W</b> - without connector <b>C9</b> - round, 9 pins <b>C12</b> - round, 12 pins <b>D9</b> - flat, 9 pins <b>D15</b> - flat, 15 pins
ORDER EXAMPLE: 1) L35T-A-0820-S-05-S-03/C9						



# PHOTOELECTRIC LINEAR ENCODER

# L37

- Distance Coded reference mark
- Reproducible thermal behavior
- Analog output signals
- Reversible reading head
- High vibration resistance



Photoelectric linear encoder L37 is an incremental encoder that features reproducible thermal behavior and has a reversible reading

head. It can have up to 3.240 mm measuring length and accuracy grades to any meter within the ML of up to  $\pm 3 \mu\text{m}$ .

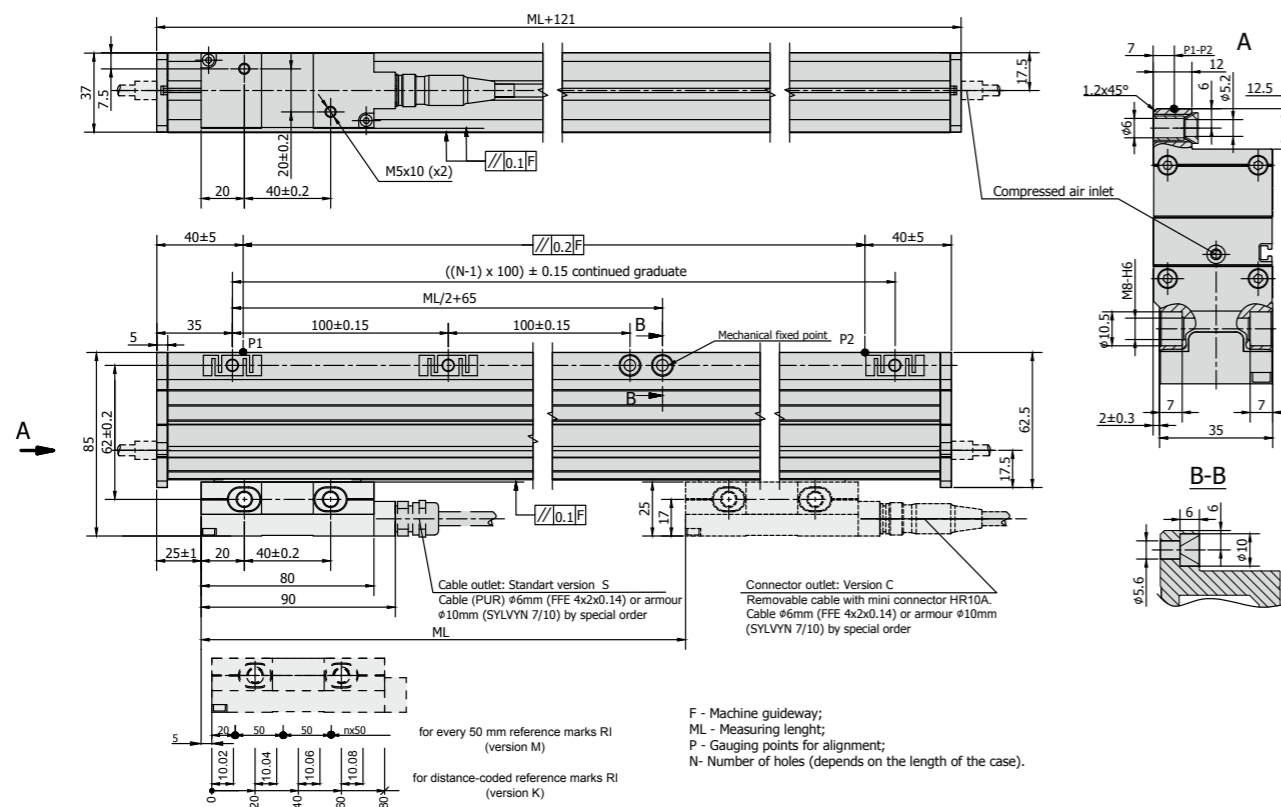

## MECHANICAL DATA

Measuring lengths (ML), mm	140, 240, 340, 440, 540, 640, 740, 840, 940, 1040, 1140, 1240, 1340, 1440, 1540, 1640, 1740, 1840, 2040, 2240, 2440, 2640, 2840, 3040, 3240	Max. traversing speed: - when interpolation factor is 1,2,5,10 - when interpolation factor is 25 - when interpolation factor is 50	1 m/s (shortly 2 m/s) 0.5 m/s 0.4 m/s
Accuracy grades to any metre within the ML (at 20°C): - for ML from 170 up to 2040 mm - or ML from 2040 up to 3240 mm	$\pm 5; \pm 3$ (optional) $\pm 10 \mu\text{m}$	Required moving force with sealing lips	< 5 N
Grating period	20 $\mu\text{m}$ ; 40 $\mu\text{m}$	Protection (IEC 529): - without compressed air - with compressed air (optional)	IP54 IP64
Reference marks (RI): - standard for ML $\leq$ 1020 mm - standard for ML > 1140 mm - optional	35mm from both ends of ML 45mm from both ends of ML one RI at any location, two or more RI's separated by distances of (n x 50 mm)	Weight	0.4 kg + 2.8 kg/m
- distance-coded - selection by magnets	see drawing standard - one magnet (RI) in ML middle	Operating temperature	0...+50°C
		Storage temperature	-20...+70°C
		Permissible vibration (40 to 2000 Hz)	$\leq 150 \text{ m/s}^2$
		Permissible shock (11 ms)	$\leq 300 \text{ m/s}^2$

## ELECTRICAL DATA

Version	L37-A $\sim 11 \mu\text{App}$	L37-AV $\sim 1 \text{Vpp}$	L37-F $\square$ TTL; $\square$ HTL
Power supply	+5 V $\pm 5\%$ / < 90 mA	+5 V $\pm 5\%$ < 90 mA	+5 V $\pm 5\%$ / < 120 mA; +12V $\pm 5\%$ / < 130 mA
Light source	LED	LED	LED
Resolution	Depends on external subdividing electronics	Depends on external subdividing electronics	5; 2.5; 1; 0.5; 0.2; 0.1 $\mu\text{m}$ (after 4-fold dividing in subsequent electronics)
Incremental signals	Two sinusoidal I1 and I2 Amplitude at 1 k $\Omega$ load: - I1 = 7-16 $\mu\text{A}$ - I2 = 7-16 $\mu\text{A}$	Differential sine +A/-A and +B/-B Amplitude at 120 $\Omega$ load: - A = 0.6-1.2 V - B = 0.6-1.2 V	Differential square-wave U1/U1 and U2/U2. Signal levels at 20 mA load current: - low (logic "0") $\leq 0.5 \text{ V}$ at Up=+5V - high (logic "1") $\geq 2.4 \text{ V}$ at Up=+5V - low (logic "0") $\leq 1.5 \text{ V}$ at Up=+12V (HTL) - high (logic "1") $\geq (Up-2) \text{ V}$ at Up=+12V (HTL)
Reference signal	One quasi-triangular I <sub>0</sub> Signal magnitude at 1 k $\Omega$ load: - I <sub>0</sub> = 2-8 $\mu\text{A}$ (usable component)	One quasi-triangular +R and its complementary -R per revolution. Signals magnitude at 120 $\Omega$ load - R = 0.2-0.8 V (usable component)	One differential square-wave U0/U0 per revolution. Signal levels at 20 mA load current: - low (logic "0") $\leq 0.5 \text{ V}$ at Up=+5V - high (logic "1") $\geq 2.4 \text{ V}$ at Up=+5V - low (logic "0") $\leq 1.5 \text{ V}$ at Up=+12V (HTL) - high (logic "1") $\geq (Up-2) \text{ V}$ at Up=+12V (HTL)
Maximum operating frequency	50 kHz (v=1 m/s) 100 kHz (v=2 m/s shortly)	50 kHz (v=1 m/s) 100 kHz (v=2 m/s shortly)	(50 x k) kHz for k=1, 2, 5, 10 1000 kHz for k=25, 50, where k- interpolation factor
Direction of signals (displacement from left to right)	I <sub>2</sub> lags I <sub>1</sub>	B+ lags A+	U <sub>2</sub> lags U <sub>1</sub>
Standard cable length	3 m, without connector	3 m, without connector	3 m, without connector
Maximum cable length	5 m	25 m	25 m
Output signals			

Note: If cable extension is used the power supply conductor section should not be smaller than 0.5 mm<sup>2</sup>.

## ACCESSORIES

CONNECTORS FOR CABLE	B12 12-pin round connector	C9 9-pin round connector	C12 12-pin round connector	D9 9-pin flat connector	D15 15-pin flat connector	RS10 10-pin round connector	ONC 10-pin round connector	HR10A 12-pins round mini connector
----------------------	-------------------------------	-----------------------------	-------------------------------	----------------------------	------------------------------	--------------------------------	-------------------------------	---------------------------------------

DIGITAL READOUT DEVICES	CS3000	CS5500
-------------------------	--------	--------

EXTERNAL INTERPOLATOR	NK
-----------------------	----

## ORDER FORM

L37	X1	X2	X3	X4	X5	X6/X7
Output signals And resolution (X1):	Measuring length (X2):	Reference Marks (X3):	Accuracy (X4):	Cable or Connector Outlet (X5):	Cable length (X6):	Connector type (X7):
<b>A</b> - Sinusoidal <b>AV</b> - Sinusoidal <b>F01</b> - TTL / HTL 0.1 $\mu\text{m}$ <b>F02</b> - TTL / HTL 0.2 $\mu\text{m}$ <b>F05</b> - TTL / HTL 0.5 $\mu\text{m}$ <b>F10</b> - TTL / HTL 1.0 $\mu\text{m}$ <b>F25</b> - TTL / HTL 2.5 $\mu\text{m}$ <b>F50</b> - TTL / HTL 5.0 $\mu\text{m}$	<b>0070</b> - 70 mm <b>0520</b> - 520 mm ... <b>3240</b> - 3240 mm	<b>N</b> - none RI <b>S</b> - standard <b>M</b> - every 50mm <b>K</b> - distance-coded <b>Ln/XXX</b> - n RI with 50-fold steps /XXX distance of the first RI from the beginning of ML, mm <b>O</b> - selection by magnets (standard - one magnet (RI) in ML middle)	<b>10</b> - $\pm 10 \mu\text{m}^*$ <b>05</b> - $\pm 5 \mu\text{m}^*$ <b>03</b> - $\pm 3 \mu\text{m}^*$ (optional)  *depends on length	<b>S</b> - version S (cable outlet) <b>C</b> - version C (connector outlet)	<b>01</b> - 1m <b>02</b> - 2m <b>03</b> - 3m ... <b>CP01</b> - 1m armoured <b>CP02</b> - 2m armoured <b>CP03</b> - 3m armoured ...	<b>W</b> - without connector <b>C9</b> - round, 9 pins <b>C12</b> - round, 12 pins <b>D9</b> - flat, 9 pins <b>D15</b> - flat, 15 pins

ORDER EXAMPLE: 1) L37-F05-2040-O-10-C-CP03/C12



# PHOTOELECTRIC LINEAR ENCODER

# L50



Photoelectric modular linear encoder L50 is an incremental encoder and has the measuring length from 3.240 up to 30.040 mm, grating

period of 40  $\mu$ m and accuracy of any meter within the ML of up to  $\pm 10 \mu$ m.

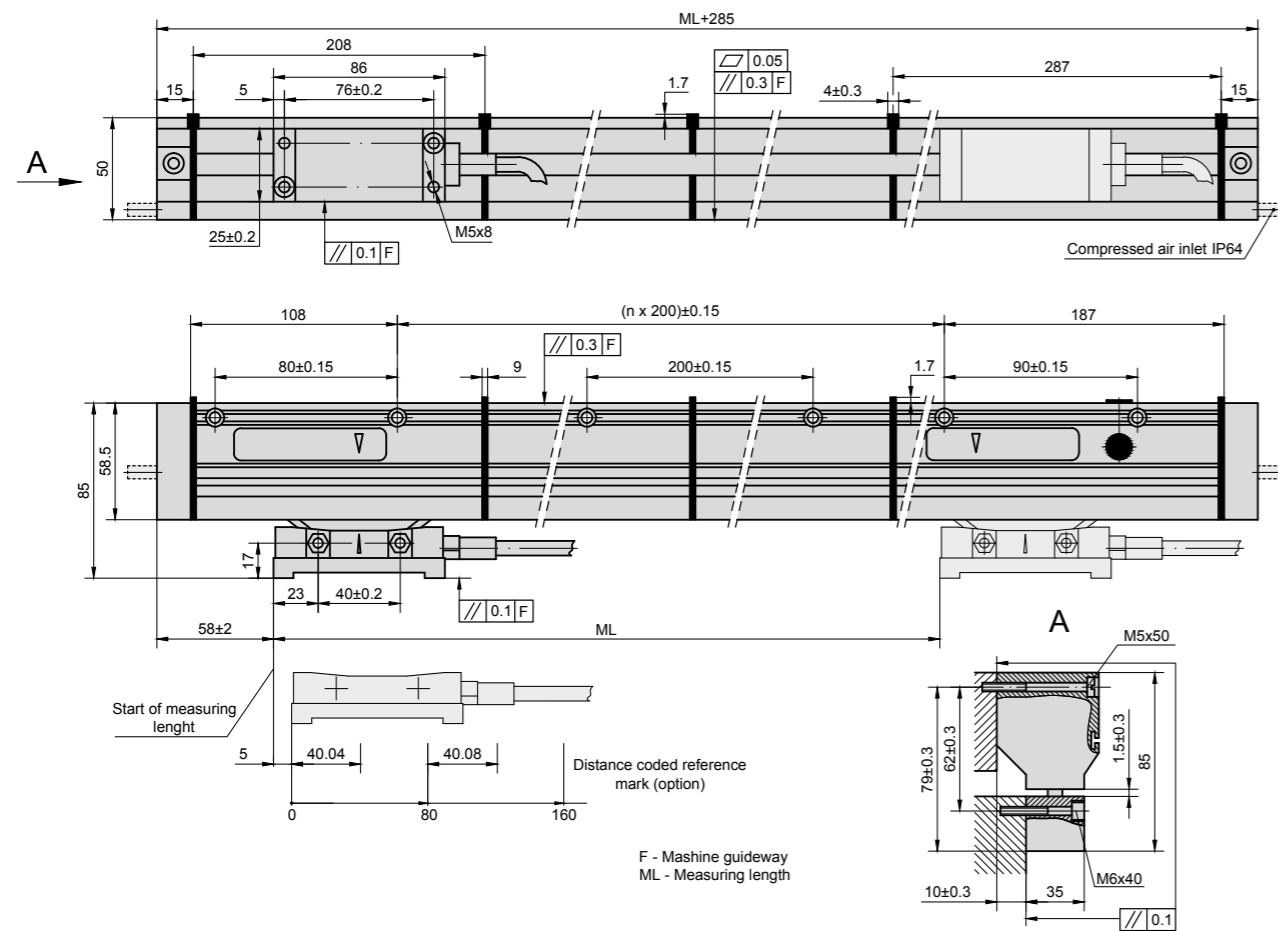

## MECHANICAL DATA

Measuring lengths (ML), mm	from 3240 up to 30040 (length of each module with steps 200 mm)	Protection (IEC 529): -without compressed air -with compressed air	IP53 IP64
Accuracy grades to any metre within the ML (at 20°C)	$\pm 10 \mu$ m/m	Weight	1.8 kg + 3.3 kg/m
Grating period	40 $\mu$ m	Operating temperature	0...+50°C
Reference marks (RI): - C - P - E	at coded distance 80 mm at constant step 50 mm selectable through magnet	Storage temperature	-20...+70°C
Max. traversing speed	60 m/s	Permissible vibration (10...2000 Hz)	$\leq 100 \text{ m/s}^2$
Required moving force	< 6 N	Permissible shock (11 ms)	$\leq 300 \text{ m/s}^2$
		Coefficient of thermal expansion	$10.6 \times 10^{-6} \text{ } ^\circ\text{C}$

## ELECTRICAL DATA

Version	L50-A $\sim 11 \mu$ App	L50-AV $\sim 1 \text{ Vpp}$	L50-F TTL
Power supply	+5 V $\pm 5\%$ / 100 mA (120 $\Omega$ )	+5 V $\pm 5\%$ / 100 mA (120 $\Omega$ )	+5 V $\pm 5\%$ / 150 mA (120 $\Omega$ )
Light source	LED	LED	LED
Resolution	Depends on external subdividing electronics	Depends on external subdividing electronics	10; 5; 2; 1 $\mu$ m (after 4-fold dividing on subsequent electronics)
Incremental signals	Two sinusoidal I1 and I2 Amplitude at 1 k $\Omega$ load: - I1 = 7-16 $\mu$ A - I2 = 7-16 $\mu$ A	Differential sine +A/-A and +B/-B Amplitude at 120 $\Omega$ load: - A = 0.6-1.2 V - B = 0.6-1.2 V	Differential square-wave U1/ $\overline{U1}$ and U2/ $\overline{U2}$ . Signal levels at 20 mA load current: - low (logic "0") $\leq 0.5 \text{ V}$ - high (logic "1") $\geq 2.4 \text{ V}$
Reference signal	One quasi-triangular I <sub>0</sub> . Signal magnitude at 1 k $\Omega$ load: - I <sub>0</sub> = 2-8 $\mu$ A (usable component)	One quasi-triangular +R and its complementary -R per revolution. Signals magnitude at 120 $\Omega$ load - R = 0.2-0.8 V (usable component)	One differential square-wave U0/ $\overline{U0}$ Signal levels at 20 mA load current: - low (logic "0") $\leq 0.5 \text{ V}$ - high (logic "1") $\geq 2.4 \text{ V}$
Direction of signals (displacement from left to right)	I <sub>1</sub> lags I <sub>2</sub> at reading head displacement from left to right	B+ lags A+ at reading head displacement from left to right	U <sub>2</sub> lags U <sub>1</sub> at reading head displacement from left to right
Standard cable length	3 m, without connector	3 m, without connector	3 m, without connector
Maximum cable length	20 m	150 m	50 m

Output signals

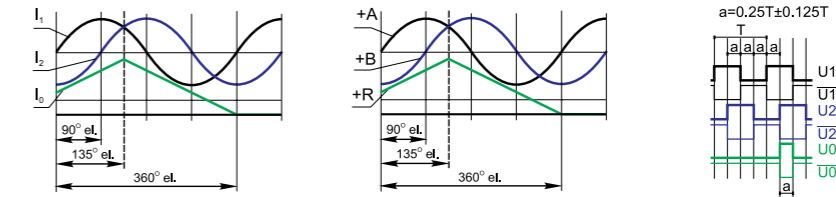

## ACCESSORIES

CONNECTORS FOR CABLE	B12 12-pin round connector	C12 12-pin round connector	D9 9-pin flat connector	D15 15-pin flat connector	RS10 10-pin round connector	ONC 10-pin round connector
DIGITAL READOUT DEVICES		CS3000			CS5500	

## ORDER FORM

L50 - X1 - X2 - X3 - X4/X5

Output signals And resolution (X1):	Measuring length (X2):	Reference marks (X3):	Cable length (X4):	Connector type (X5):
<b>AV</b> - Sinusoidal <b>F10</b> - TTL 1 $\mu$ m <b>F20</b> - TTL 2 $\mu$ m <b>F50</b> - TTL 5 $\mu$ m <b>F100</b> - TTL 10 $\mu$ m	<b>3240</b> - 3240 mm <b>5240</b> - 5240 mm ... <b>30400</b> - 30400 mm	<b>C</b> - at coded distance (80mm) <b>P</b> - at constant step (50mm) <b>E</b> - selectable through magnet	<b>01</b> - 1m <b>02</b> - 2m <b>03</b> - 3m ...	<b>W</b> - without connector <b>B12</b> - round, 12 pins <b>C12</b> - round, 12 pins <b>D9</b> - flat, 9 pins <b>D15</b> - flat, 15 pins <b>RS10</b> - round, 10 pins <b>ONC</b> - round, 10 pins

ORDER EXAMPLE: 1) L50-AV-30400-C-04/C12

# MAGNETIC LINEAR ENCODER

# MT



Analog output signals



Long measuring distance



Magnetic Technology



Magnetic linear encoder MT has measuring length of up to 50.000 mm and accuracy up to  $\pm 25 \mu\text{m}$ .

Other parameters differ depending on required modifications.

## MODIFICATION MT

VERSION 1 (POWER SUPPLY +5V)

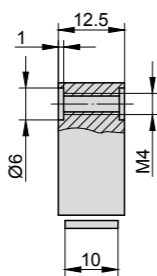
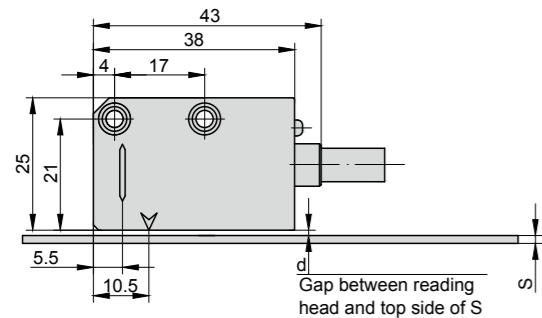

VERSION 2 (POWER SUPPLY +[5...28]V)

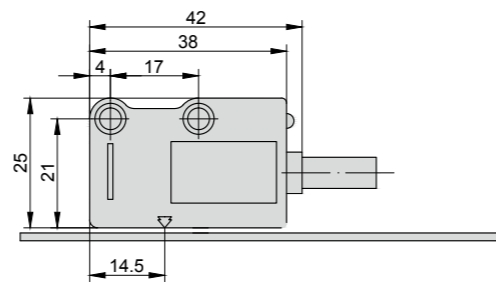

	MPx00	MPx00+CV	MPx00+SP	MPx00Z	MPx00Z+CV	MPx00Z+SP
S(mm)	1.3	1.6	2.1	1.3	1.6	2.1
d(mm) MT P	0.1 + 0.4	-				
d(mm) MT M	0.2 + 1.4	1.1 MAX	0.6 MAX	0.3 + 0.8	0.5 MAX	Impossible
d(mm) MT H	0.3 + 4.0	3.7 MAX	3.2 MAX	0.35 + 2.0	1.7 MAX	1,2 MAX

d - distance between reading head and magnetic band MP or protective cover CV (protective support SP)

To get the best accuracy distance d must be the lowest possible (in the indicated range)

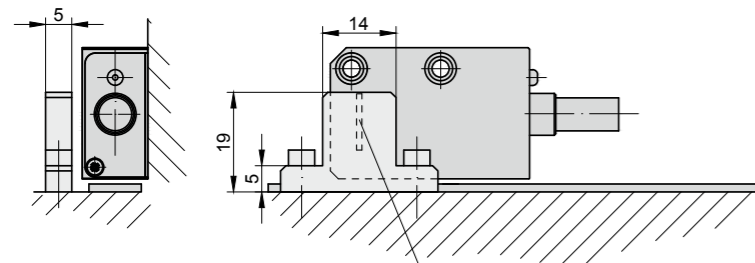
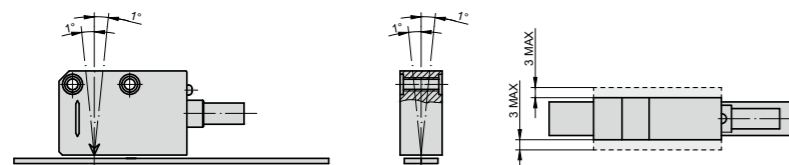

Reference marks

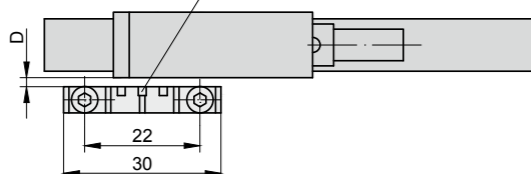

	MT.....C MT.....E	MT.....Z
a (mm)	3 MAX	1 MAX

	D (mm)	
MTP (MP100)	-	-
MTM (MP200)	1.5 nom.	2 MAX
MTH (MP500)	1 nom.	2 MAX

D - distance between external zero signal actuator and reading head

## MODIFICATION CMT

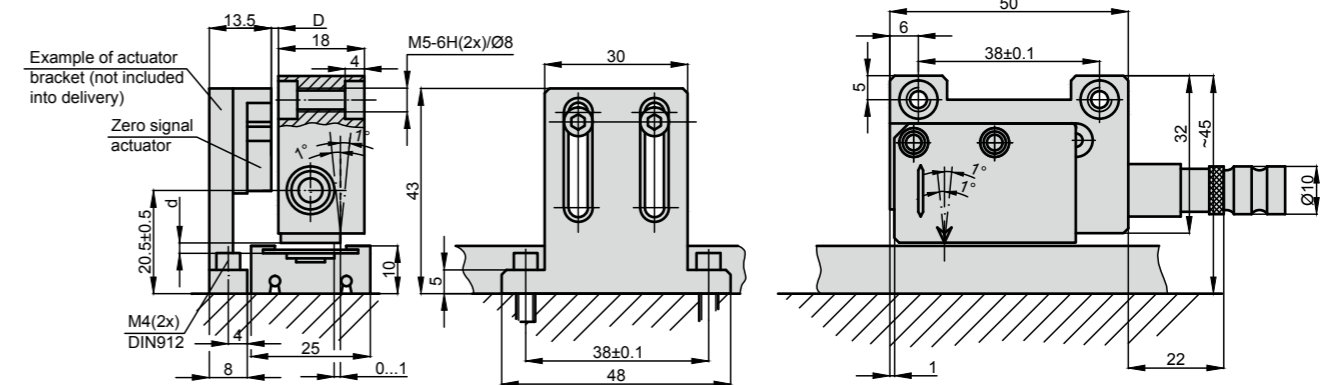

	D (mm)	
CMTM (MP200)	1.5 nom	2.5 MAX
CMTH (MP500)	1 nom	2 MAX

Gap "d" between protective cover and reading head:

- for CMTM - d = 0.3...0.7 mm;
- for CMTM - d = 0.3...2.2 mm;
- for CMTM - d = 0.1...0.3 mm

Warning: To get the best accuracy distance d must be the lowest possible (in the indicated range).

D - distance between external zero signal actuator and reading head

## MODIFICATION PCMT

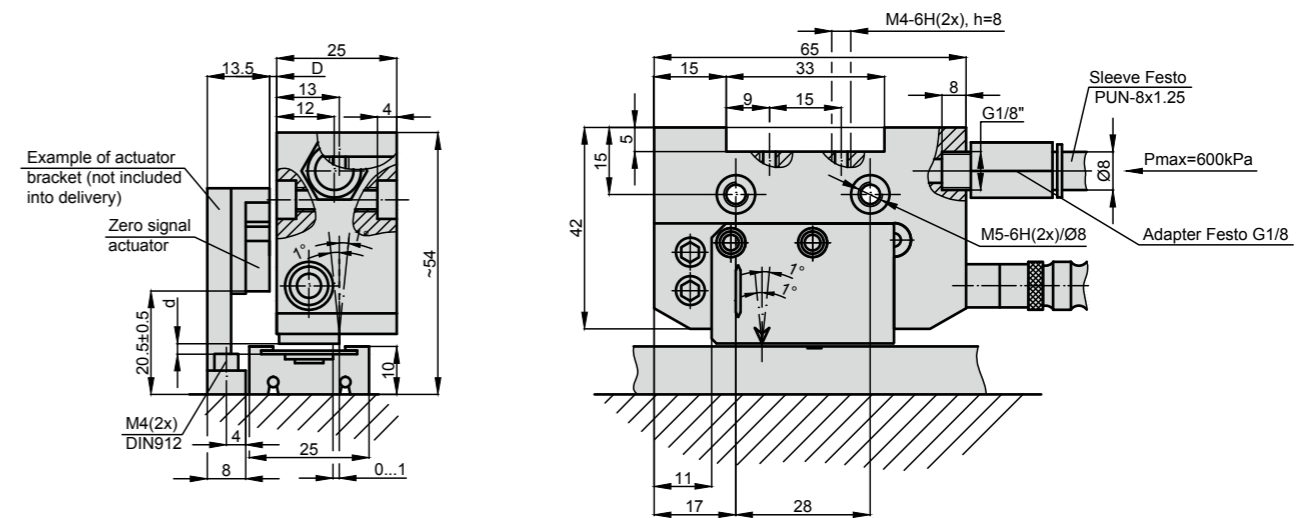

	D (mm)	
CMTM (MP200)	1.5 nom	2.5 MAX
CMTM (MP500)	1 nom	2 MAX

Gap "d" between protective cover and reading head:

- for CMTM - d = 0.3...0.7 mm;
- for CMTM - d = 0.3...2.2 mm;
- for CMTM - d = 0.1...0.3 mm

Warning: To get the best accuracy distance d must be the lowest possible (in the indicated range).

D - distance between external zero signal actuator and reading head

## ACCESSORIES

CONNECTORS FOR CABLE	B12 12-pin round connector	C12 12-pin round connector	D9 9-pin flat connector	D15 15-pin flat connector	RS10 10-pin round connector	ONC 10-pin round connector
DIGITAL READOUT DEVICES		CS3000			CS5500	

## SPECIFICATION

	TTL output signals (F)	Sine wave output signals (AV) - version 2 only
Measuring length (ML)	up to 50 m (20 m with MP 500)	up to 50 m (20 m with MP 500)
Repeatability	± 1 increment	± 1 increment
Max. measuring frequency	300kHz	See tables below
Power supply - version 1 - version 2	5V DC ± 5% (5 ... 28) V DC ± 5%	– (5 ... 28) V DC ± 5%
Current consumption without load	60 mA max	90 mA max
Current consumption with load	140 max (with 5V and R=120Ω); 115 max (with 12V and R=1.2kΩ) 90 max (with 28V and R=1.2Ω)	10 max (with 5V and R=12Ω)
Phase shift between signals	90° ± 5°	90° ± 5°
Protection (IEC 529)	IP67	IP67
Operating temperature - version 1 - version 2	-20...+85 °C 0...+50 °C	– 0...+50 °C
Storage temperature	-20...+85 °C	-20...+85 °C
Permissible humidity	100% non-condensing	100% non-condensing
Permissible vibration (55...2000 Hz)	300 m/s <sup>2</sup>	300 m/s <sup>2</sup>
Permissible shock (11 ms)	1000 m/s <sup>2</sup>	1000 m/s <sup>2</sup>
Output signal shape	Square-wave TTL or HTL pulses	Sine wave
Output signals	two main + one zero and their complementary	two main sine wave + one zero squ
Output scheme	Line driver	Line driver
Weight of reading head - MT - CMT - PCMT	40 g 100 g 100 g	40 g 100 g 100 g
Standard cable length	2.0 m	2.0 m
Max. cable length of head	10.0 m	10.0 m
Max. cable length of encoder (2 m of head + adapter)	100.0 m	100.0 m
Electrical protections	from inversion of power supply polarity; from short circuit on output port	

## READING HEAD VERSION P (MTP, CMT, PCMT)

	TTL output signals (F)	Sine wave output signals (AV) - version 2 only
Reference (zero) signal	Without reference signal (version C)	Without reference signal (version C)
Pole pitch	1+1 mm	1+1 mm
Accuracy*	up to ±6 μm	up to ±6 μm
Resolution (after x4 in CNC)	0.5; 1; 5; 10 μm	500 μm
Max. traversing speed: - MTP-F05 - MTP-F100	0.6 m/s 6 m/s	12 m/s
Max. measuring frequency	300 kHz	12 kHz

## READING HEAD VERSION M (MTM, CMTM, PCMTM)

	TTL output signals (F)	Sine wave output signals (AV) - version 2 only
Reference (zero) signal	Constant pitch every 2 mm (version C) With external actuator (version E). Reference marks are made with constant pitch 2 mm Reference marks made on magnetic band according customer requirements (version Z)	Constant pitch every 2 mm (version C) With external actuator (version E). Reference marks are made with constant pitch 2 mm.
Pole pitch	2+2 mm	2+2 mm
Accuracy*	up to ±8 μm	up to ±8 μm
Resolution (after x4 in CNC)	1;5;10;25;50;100,500 μm	1000 μm
Max. traversing speed: - MTM-F10 - MTM-F100	1,2 m/s 12 m/s	1,2 m/s 12 m/s
Max. measuring frequency	300 kHz	6 kHz

## READING HEAD VERSION H (MTH, CMTH, PCMTH)

	TTL output signals (F)	Sine wave output signals (AV) - version 2 only
Reference (zero) signal	Constant pitch every 5 mm (version C) With external actuator (version E). Reference marks are made with constant pitch 5 mm Reference marks made on magnetic band according customer requirements (version Z)	Constant pitch every 5 mm (version C) With external actuator (version E). Reference marks are made with constant pitch 5 mm.
Pole pitch	5+5 mm	5+5 mm
Accuracy*	up to ±30 μm	up to ±30 μm
Resolution (after x4 in CNC)	5; 10; 25; 50 μm	2500 μm
Max. traversing speed: - MTH-F50 - MTH-F250	6 m/s 30 m/s	12 m/s
Max. measuring frequency	300 kHz	2,4 kHz

\*The smaller is the gap between reading head and magnetic band the better is accuracy of encoder.  
Version E - zero signal is generated when external zero actuator acts to reference mark, which is made on magnetic band.  
It is possible to use several actuators.  
Version Z - zero signal is generated when reference mark is acted by actuator incorporated into reading head.

## MAGNETIC BAND

Accuracy (at 20°C)	±30 (standard); ±15 (optional) μm/m
Width	10 mm
Thickness	1.3 mm
Length	50 m max. (20 m max.- for MP 500)
Thermal expansion coefficient	10,5 x 10 <sup>-6</sup> °C <sup>-1</sup> (at 20°C±0,1°C)
Bend radius	130 mm min.
Weight of magnetic band	65 g/m
Weight of protective cover	25 g/m
Operating temperature	0...+70 °C
Storage temperature	-20...+80 °C

Note: In order to ensure the accuracy of encoder magnetic band must be longer than ML by 80 mm (40 mm from each side)

MAGNETIC BAND	MP100	MP200/MP200Z	MP500/MP500Z
Pole pitch	1+1 mm	2+2 mm	5+5 mm
Reference mark position	-	on request from left or right at pitches of 4 mm or multiples	on request from left or right at pitches of 10 mm or multiples
	<i>Note: With MP100 magnetic band, it is not possible to use any protective cover (CV or SP)</i>	<i>Note: Magnetic band MP200Z is used only with reading head MTMxxxZ</i>	<i>Note: Magnetic band MP500Z is used only with reading head MTXxxxZ</i>

## PROTECTIVE BAND CV

Stainless steel cover CV (width 10 mm, thickness 0,3 mm) for magnetic band MP protection is glued on magnetic band (excluding MP100)

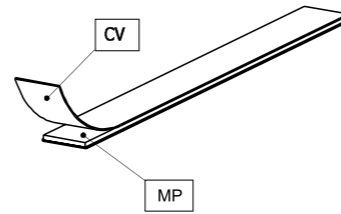

## PROTECTIVE SUPPORT SP

Aluminium protective support SP for magnetic band MP protection. Fixed on machine surface and holds magnetic band. It is not possible to use the support SP if the magnetic band is already covered by stainless steel band CV.

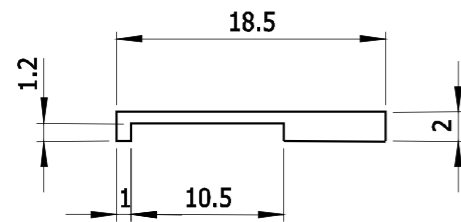
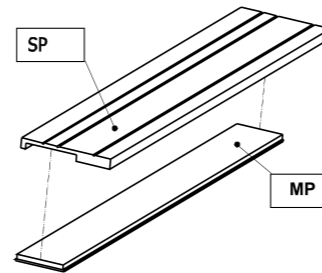

## PROFILE RAIL PS

Profile rail PS with protective band SB is used for support of magnetic band with width 10 mm. Profile rail is easy mounted and has not adhesive joints. The lengths of more than 1 m are obtained by joining together several rail modules.

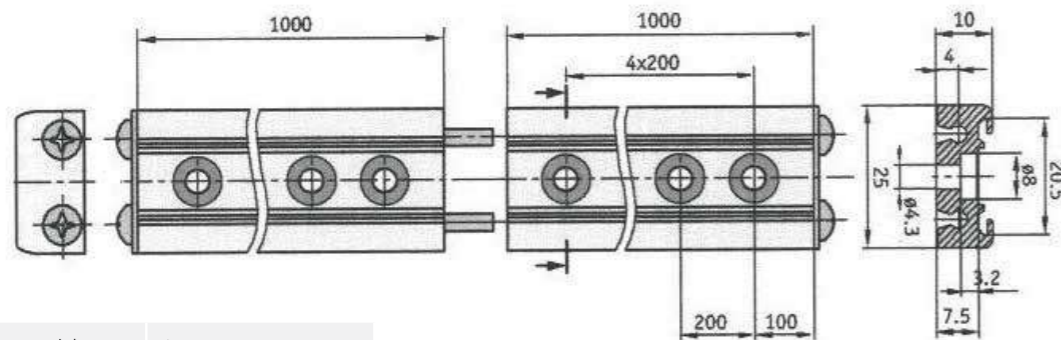

Length of one module	1 m
Length	up to 50 m (pitch 1 m)
Width and height	25x10 mm
Material	aluminium

## PROTECTIVE BAND SB

Protective band SB is used for sliding into profile rail PS.

Length	up to 50 m
Material	aluminium

## OUTPUT SIGNALS

### TTL output signals

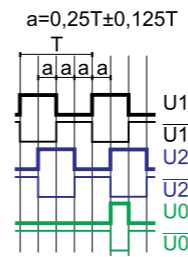

### AV output signals - version 2 only

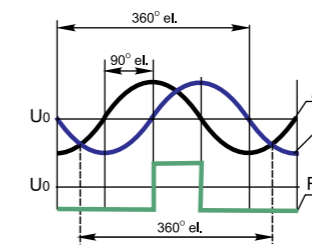

A and B amplitude 0,6 V...1,2 V (~ 1V)

R amplitude 0,25...0,6V (useful part)

A and B phase shift  $90^\circ \pm 10^\circ$  el.

Reference voltage  $U_0$  2,5 V

Amplitudes of signals are referred to measurement made with 120  $\Omega$  impedance and power supply voltage of reading head  $5V \pm 5\%$ .

## ORDER FORM

X1MT - X2 - X3 - X4 - X5 - X6 - X7 - X8 - X9/X10

Modification (X1):	Reading head Version (X2):	Reference marks (X3):	Power supply (X4):	Magnetic band (mp) (X5):	Protective steel Cover cv (X6):	Or Aluminium protective support sp (X7):	External Reference Mark Actuator sme (X8):	Cable length (X9):	Connector Type (X10):
MT CMT PCMT	P - MTP M - MTM H - MTH	C - standard, without reference mark; E - with external reference mark actuator; Z/L - made on magnetic band by order at any place. L - distance in mm from begin of ML	1 - 5V DC $\pm 5\%$ 2 - 5...28V DC $\pm 5\%$	MP100/01 - 1m MP200/01 - 1m MP200Z/01 - 1m MP500/01 - 1m MP100/02 - 2m MP100/03 - 3m ... (20 m max for MP500)	W - without CV CV/01 - 1m CV/02 - 2m CV/03 - 3m ...	W - without SP SP/01 - 1m SP/02 - 2m SP/03 - 3m PS/01 - 1m ...	0 - without SME 1 - with SME	01 - 1m 02 - 2m 03 - 3m ...	W - without connector C12 - round, 12 pins D9 - flat, 9 pins D15 - flat, 15 pins

ORDER EXAMPLE: 1) MTM-MTP-C-1-MP200/03- SP/03-W-0-02/W  
2) PCMTM-MTH-E-2-MP500/05-CV/05-W-1-02/D9



# MAGNETIC LINEAR ENCODER

# MK



Magnetic absolute linear encoder MK has measuring length of up to 30.000 mm, accuracy can reach up to  $\pm 35 \mu\text{m}$ . The encoder has two versions of serial interface - SSI or BiSS C, but optionally it can

have 2 analog sinusoidal signals with phase shift  $90^\circ\text{C}$  and amplitude approx. 1Vpp.

## MECHANICAL DATA

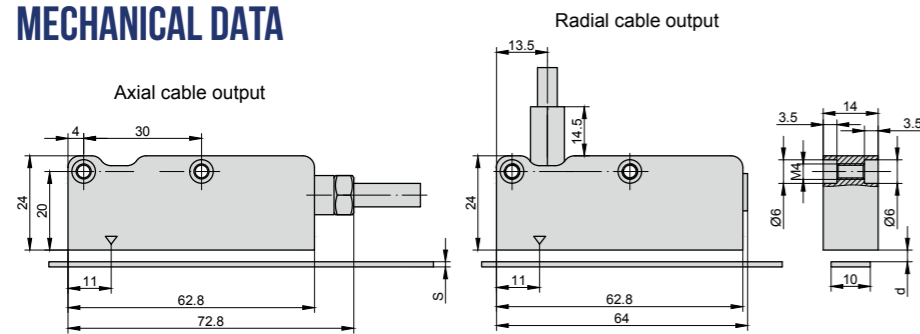

Value, mm	MP200A	MP200A +CV	MP200A +SP
s	1.3	1.6	2.1
d	0.3 + 1.0	0.7 MAX	0.2 MAX

s - thickness

d - distance between reading head and magnetic band MP or protective cover CV (protective support SP)

Permissible tolerances for reading head mounting

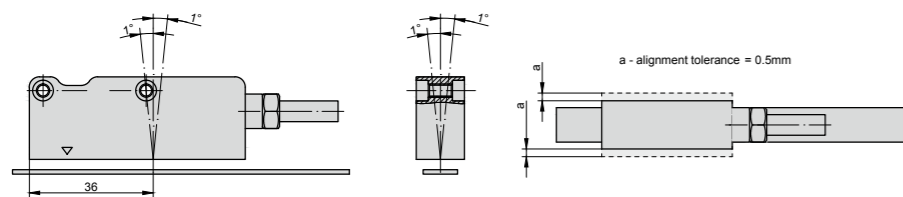

## MK PARAMETERS

Pole pitch	2+2 mm	Current consumption with load	150 mA max. (with R=120 $\Omega$ ) 5Vdc 100 mA max. (with R=1200 $\Omega$ ) 24Vdc
Measuring length (ML)	up to 30 m	Protection (EN 60529)	IP67
Incremental signal	since wave 1Vpp (optional)	Operating temperature	0...+50 °C standard -20...+80 °C on request
Resolution 1Vpp	up to 1 $\mu\text{m}$ (depending on CNC division factor)	Storage temperature	-30...+90 °C standard -45...+90 °C on request
Repeatability	$\pm 1$ increment	Permissible humidity	100%
Signal period	2 mm	Permissible vibration (55...2000 Hz)	200 m/s <sup>2</sup>
Serial interface	SSI or BiSS	Permissible shock (11 ms)	1000 m/s <sup>2</sup>
Resolution absolute position	500, 100, 50, 10, 5, 1 $\mu\text{m}$	Weight of reading head	80 g
Accuracy	$\pm 15 \mu\text{m}$	Electrical protections	from inversion of power supply polarity and from short circuit on output port
Max. traversing speed	300 m/min	Standard cable length / max. cable length	2.0 / 20.0 m (50 m if power supply is 5V length)
Power supply	(5 ... 28 V) DC $\pm 5\%$		

## OUTPUT SIGNALS

<b>Interface</b>	SSI Binary - Gray	BiSS C unidirectional
<b>Signals level</b>	EIA RS 485	EIA RS 485
<b>Clock frequency</b>	0.1 $\div$ 1.2 MHz	0.1 $\div$ 4 MHz
<b>n</b>	Position bit	26 + 2 + bit
<b>Tc</b>	12 $\div$ 65 $\mu\text{s}$	12 $\div$ 20 $\mu\text{s}$

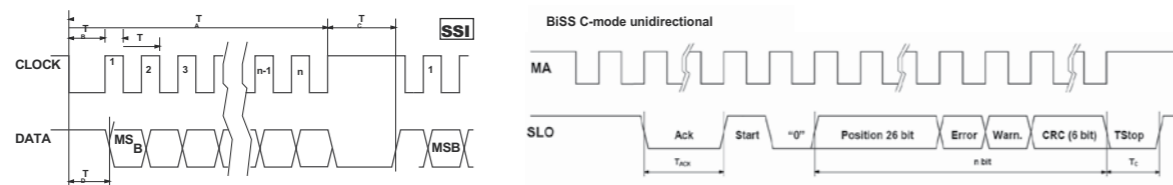

## CABLE

### Cable for serial output:

- 6-wire shielded cable,  $\varnothing=7$  mm, PVC external sheath, with low friction coefficient, oil-resistant, suitable for continuous movements
- conductors section: supply 0.25 mm<sup>2</sup>, signals 0.25 mm<sup>2</sup>
- cable's bending radius should not be lower than 35 mm.

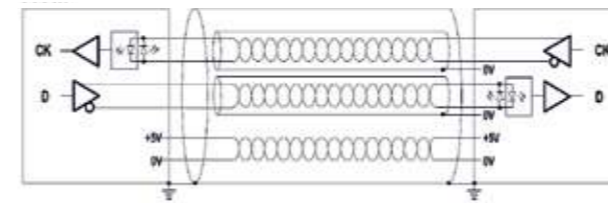

NOTE: Encoder is supplied with flexible cable, that consists of twisted pair of wires (for informational signals SSI-BiSS).

### Cable for analog output + serial output:

- 10-wire shielded cable,  $\varnothing = 7.1$  mm, PUR external sheath. Inside the cable, a further shield for the twisted pair of the digital signals (SSI-BiSS) is presented.
  - conductors section: supply 0.35 mm<sup>2</sup>, signals 0.10 mm<sup>2</sup>
  - cable's bending radius should not be lower than 45 mm.
- In case of cable extension, it is necessary to guarantee:
- electrical connection between the body of the connectors and the cables shield;
  - minimum power supply voltage of 5 V to the head.

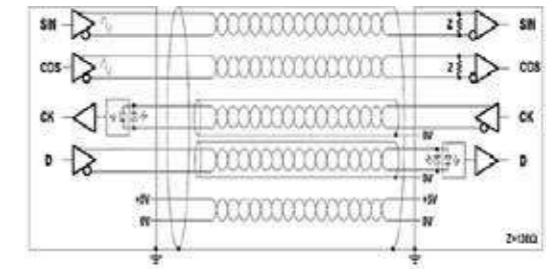

## PROTECTIVE BAND CV

Stainless steel cover CV (width 10 mm, thickness 0,3 mm) for magnetic band MP protection is glued on magnetic band.

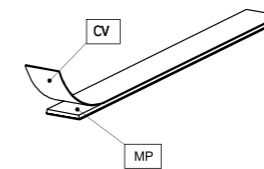

## PROTECTIVE SUPPORT SP

Aluminium protective support SP for magnetic band MP protection. Fixed on machine surface and holds magnetic band. It is not possible to use the support SP if the magnetic band is already covered by stainless steel band CV.

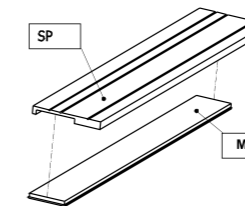

## MAGNETIC BAND MP200A

Pole pitch	2+2 mm
Accuracy (at 20 °C)	$\pm 20; \pm 80 \mu\text{m/m}$
Width	10 mm
Thickness	1,3 mm
Length	30 m max.
Bend radius	80 mm min.
Weight of magnetic band	65 g/m
Weight of protective cover	25 g/m
Operating temperature	0...+70 °C
Storage temperature	20...+80 °C

## ACCESSORIES

CONNECTORS FOR CABLE	B12 12-pin round connector	C12 12-pin round connector	D9 9-pin flat connector	D15 15-pin flat connector	RS10 10-pin round connector	ONC 10-pin round connector
DIGITAL READOUT DEVICES		CS3000				CS5500

## ORDER FORM

MK	X1	X2	X3	X4	X5	X6	X7/X8
<b>Absolute resolution (X1):</b>	F10 - 1 $\mu\text{m}$	F50 - 5 $\mu\text{m}$	F100 - 10 $\mu\text{m}$	F500 - 50 $\mu\text{m}$	F1000 - 100 $\mu\text{m}$	F5000 - 500 $\mu\text{m}$	
<b>Output signals (X2):</b>	S1 - SSI binary	S2 - SSI binary+even parity	S3 - SSI binary+odd parity	S4 - SSI binary+error	S5 - SSI binary+even parity+error	S6 - SSI binary+odd parity+error	S7 - SSI Gray B1 - BiSS binary
<b>Incremental signals (X3):</b>	W - without incremental signals	V - 1Vpp					
<b>Magnetic Band length (X4):</b>	MP200A/01 - 1m	MP200A/02 - 2m	MP200A/03 - 3m			MP200A/20 - 20m	
<b>Protective steel cover length (X5):</b>	CV/01 - 1m	CV/02 - 2m	CV/03 - 3m				
<b>Or aluminium protective support (X6):</b>	SP/01 - 1m	SP/02 - 2m	SP/03 - 3m				
<b>Cable length and output (X7):</b>	A01 - 1m axial	A02 - 2m	...	R01 - 1m radial	R02 - 2m	...	
<b>Connector Type (X8):</b>	W - without connector	B12 - round, 12 pins	C12 - round, 12 pins	D9 - flat, 9 pins	D15 - flat, 15 pins		

ORDER EXAMPLE: 1) MK-F10-S2-V-MP200A/02- SP/02-A02/C12

# ACCESSORIES

Precizika Metrology manufactured encoders are accompanied by a variety of different accessories. These include encoder couplings, external interpolators, dig-

ital readout devices and connectors. There are many options of these accessories depending on customer requirements and needs.



# SC



## MECHANICAL DATA

Coupling model	SC30	SC70	SC98-1	SC98-2
Kinematic accuracy (with parallel offset $\leq 0.05$ mm and angular misalignment $\leq 0.09^\circ$ )	$\pm 10$ arc sec	$\pm 2$ arc sec	$\pm 0.5$ arc sec	$\pm 1$ arc sec
Torsional rigidity	150 Nm/rad	4000 Nm/rad	6000 Nm/rad	4000 Nm/rad
Permissible torque	0.1 Nm	0.5 Nm	1 Nm	1 Nm
Moment of inertia (approx.)	$3 \times 10^{-6}$ kgm <sup>2</sup>	$2 \times 10^{-4}$ kgm <sup>2</sup>	$2 \times 10^{-4}$ kgm <sup>2</sup>	$1.7 \times 10^{-4}$ kgm <sup>2</sup>
Permissible radial misalignment	$\leq 0.2$ mm	$\leq 0.3$ mm	$\leq 0.3$ mm	$\leq 0.3$ mm
Permissible angular error	$\leq 1^\circ$	$\leq 0.5^\circ$	$\leq 1^\circ$	$\leq 2^\circ$
Permissible axial misalignment	$\leq 0.2$ mm	$\leq 0.2$ mm	$\leq 0.2$ mm	$\leq 0.2$ mm
Permissible shaft speed	16000 rpm	3000 rpm	1000 rpm	1000 rpm
Weight	0.027 kg	0.22 kg	0.25 kg	0.21 kg
Encoder compatibility	A28, A36, AK36, AM, AK50, A58, AK58, AP58	A110	A170	A170

## SC30

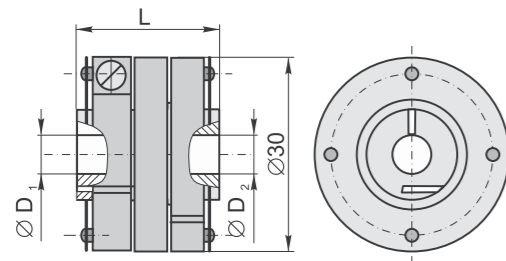

L
22
30

D <sub>1</sub>	D <sub>2</sub>
Ø4H7, Ø5H7, Ø6H7, Ø7H7,	
Ø8H7, Ø10H7, Ø1/4",	
Ø5/16", Ø3/8"	



## ORDER FORM

Model (X1):	Diameter d <sub>1</sub> (X2):	Diameter d <sub>2</sub> (X3):	*Length (X4)
SC30	04 - Ø4mm	04 - Ø4mm	22 - 22mm
SC70	05 - Ø5mm	05 - Ø5mm	30 - 30mm
SC98-1	...	...	*only for SC30
SC98-2	...	...	

ORDER EXAMPLES: 1) SC30-05/05-22  
2) SC98-2  
3) SC70-10/14

## SC70

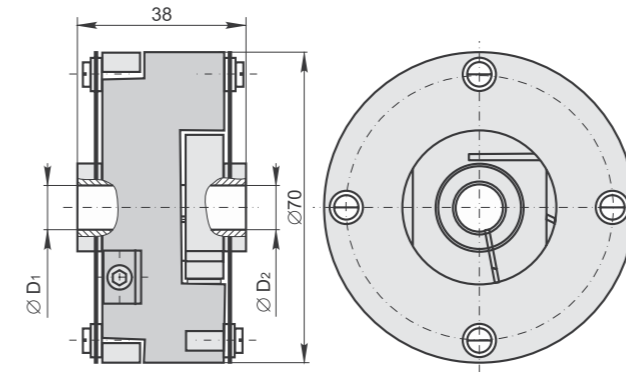

D <sub>1</sub>	D <sub>2</sub>
Ø10F7	
Ø14F7	



## SC98-1

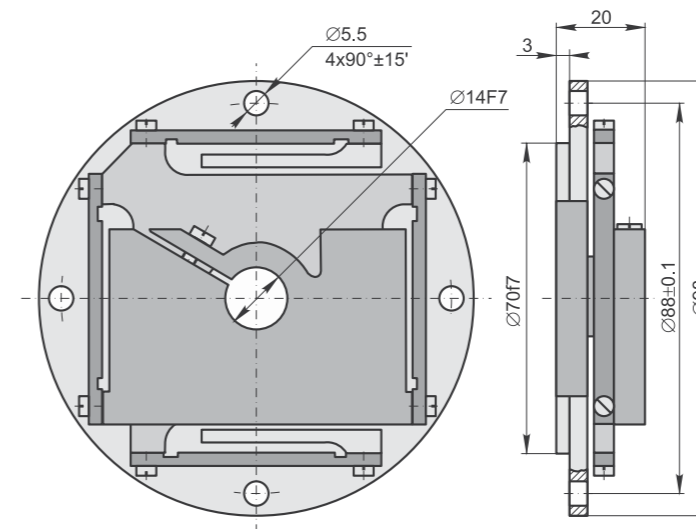

## SC98-2

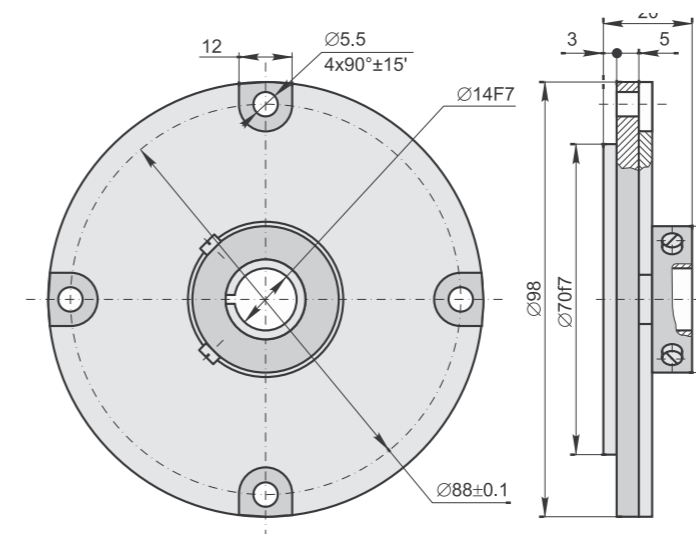



# EXTERNAL INTERPOLATOR

# NK

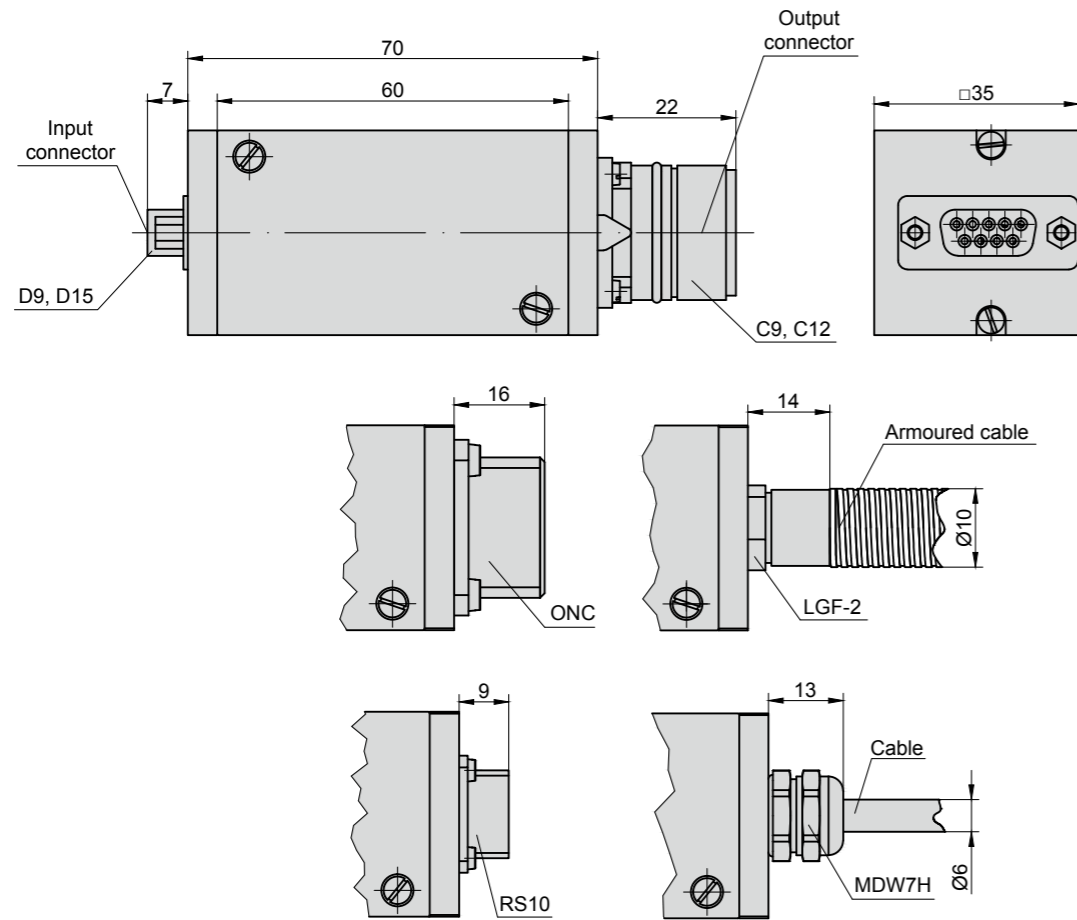

## MECHANICAL DATA

Input signals (A): - Incremental signals - Reference signal	7-16 mA 2-8 mA
Input signals (AV): - Incremental signals - Reference signal	0.6-1.2V 0.2-0.8V
Output signals	TTL(RS422) compatible
Operating voltage	5 V
Max input frequency	50 kHz
Possible input connector / cable	C9, C12, D9, D15, ONC, RS10 / cable, armoured cable
Possible output connector / cable	C12, D9, D15, ONC, RS10 / cable, armoured cable
Signal interpolation*: - NK-1 - NK-2 - NK-3 - NK-4 - NK-5 - NK-8 - NK-10 *interpolation factor up to x100 on request	1 - fold 2 - fold 3 - fold 4 - fold 5 - fold 8 - fold 10 - fold
Encoder compatibility	A24HME1, A28, A36, A42M, A75M, A58, A58HE, A58HE1, A58HME, A102H, A90H, A110, A110H, A170, A170H, A200H, L18, L18B, L18T, L35, L35T, L37, L50, MT.

The positions of switches depending on interpolation factor and linear/rotary encoder reference mark width

Reference mark width T/4						Reference mark width T/2								
Switches position	1	2	3	4	5	Interpolation factor	Switches position	1	2	3	4	5	6	Interpolation factor
						1								1
						8								8
						10								10

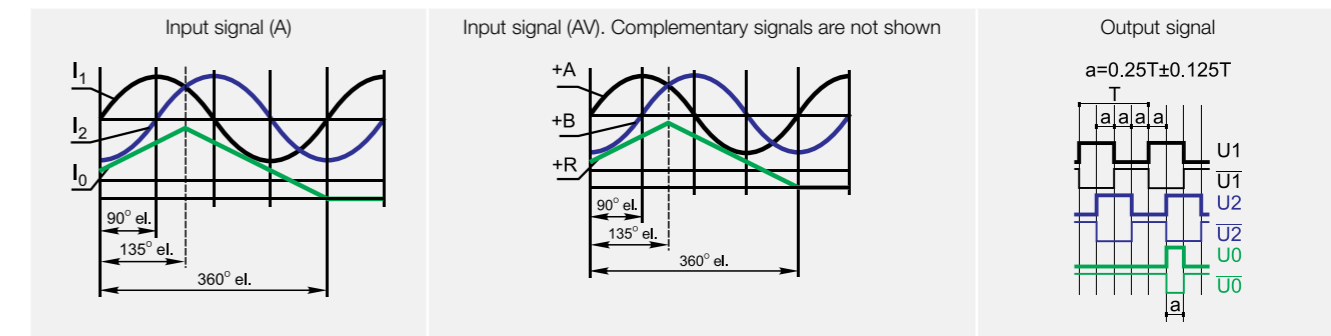

## ORDER FORM

NK - X1 - X2 - X3 - X4/X5 - X6 - X7/X8

Input signals (X1):	Interpolation factor (X2):	Input connector (female) or cable type (X3):	Input cable length (if c or cp selected) (X4):	Connector on input cable end (X5):	Output connector (male) or cable type (X6):	Output cable length (if c or cp selected) (X7):	Connector on output cable end (X8):
A - 11µA AV - 1Vpp	1 2 3 4 5 8 10	D9 - flat, 9 pins D15 - flat, 15 pins, 3 rows C9 - round, 9 pins C12 - round, 12 pins RS10 - round, 10 pins ONC - round, 10 pins C - cable Ø6mm CP - armoured cable Ø10mm	W - without cable 01 - 1 m 02 - 2 m 03 - 3 m ...	W - without connector D9 - flat, 9 pins D15 - flat, 15 pins, 3 rows RS10 - round, 10 pins ONC - round, 10 pins	D9 - flat, 9 pins D15 - flat, 15 pins, 3 rows C12 - round, 12 pins RS10 - round, 10 pins ONC - round, 10 pins C - cable Ø6mm CP - armoured cable Ø10mm	W - without cable 01 - 1 m 02 - 2 m 03 - 3 m ...	W - without connector B12 - round, 12 pins C9 - round, 9 pins C12 - round, 12 pins D9 - flat, 9 pins D15 - flat, 15 pins RS10 - round, 10 pins ONC - round, 10 pins

ORDER EXAMPLES: 1) NK-A-5-C-01/D15-C-02-C12  
2) NK-AV-10-D9-W/W-D15-W/W

## ACCESSORIES

CONNECTORS FOR CABLE	B12 12-pin round connector	C9 9-pin round connector	C12 12-pin round connector	D9 9-pin flat connector	D15 15-pin flat connector	RS10 10-pin round connector	ONC 10-pin round connector
CONNECTORS ON HOUSING		C9 9-pin round connector	C12 12-pin round connector	D9 9-pin flat connector	D15 15-pin flat connector	RS10 10-pin round connector	ONC 10-pin round connector
CABLE	Cable ø6 mm			Armoured cable ø6 mm			
DIGITAL READOUT DEVICES	CS3000			CS5500			



TWO AND THREE AXIS  
READOUT DEVICES

# CS 3000



## TECHNICAL DATA

Input standard	RS 422
Power supply for encoders	+5 V DC
Resolution of linear encoders	0.5; 1; 2; 5; 10; 20; 50 µm; 0.1; 0.2; 0.5; 1; 5; 10 mm
Resolution of rotary encoder	1° - 0,0001°
LED green display, 7 digit and sign	14 mm height
Maximum input signals frequency	100 kHz
Power supply	DC 8-30 V/0.8A Power supply adapter: - input: AC 100V ~ 240V, 50Hz/60Hz - output: DC 8~30 V; 0,8A
Power consumption	5 W
Overall dimensions	214 x 139 x 29.5 mm
Weight	0.9 kg
Operation temperature range	0 °C - +50 °C

## FEATURES

- Measuring in millimeters or inches (inch/mm)
- Radius calculation (1/2)
- Measuring in relative or absolute coordinate system (INC/ABS)
- Entering or setting zero values for the selected axis
- Memory for last position after switch off
- Linear movement measurement (by means of linear encoders)
- Rotary movement measurement (by means of rotary encoders)
- Movement direction indication
- Error correction: linear compensation
- Serial interface RS232

## MECHANICAL DATA

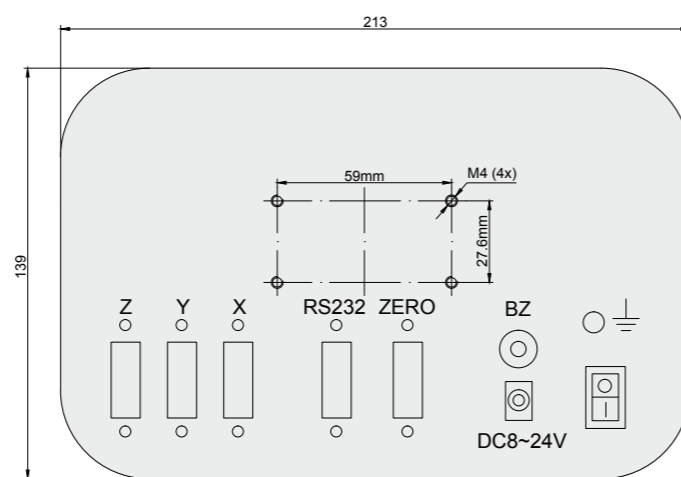

Connected only through 15-pins flat connector D15.

## ORDER FORM

CS	-	X1	-	X2
Digital readout device (X1):	Number of axis (X2):			
3000 - two or three axis	2 - two axis		3 - three axis	
ORDER EXAMPLE: 1) CS-3000-2				

## COMPATIBLE WITH:

A2HME1, A28, A36, A42M, A75M, A58M, A58B, A58C, A58C2, A58C3, A58D, AP58, A58HE, A58HE1, A58HME, A102H, A90H, A110, A110H, A170, A170H, A200H, L18, L18B, L18T, L23, L35, L35T, L37, L50, MT.

TWO AND THREE AXIS  
READOUT DEVICES

# CS 5500



## TECHNICAL DATA

Input standard	RS 422
Power supply for encoders	+5 V DC
Resolution of linear encoders	0.1; 0.2; 0.5; 1; 2; 5; 10; 20; 50 µm;
Resolution of rotary encoder	1° - 0,0001°
LED green display, 7 digit and sign	14 mm height
Maximum input signals frequency	500 kHz
Power supply	AC 85V ~ 230V
Power consumption	5 W
Overall dimensions	295 x 182 x 30.5 mm
Weight	2.6 kg
Operation temperature range	0 °C - +50 °C

## FEATURES

- Measuring in millimeters or inches (inch/mm)
- Measuring system calibration in relation to reference point (REF)
- Radius calculation (1/2)
- Measuring in relative or absolute coordinate system (INC/ABS)
- Entering or setting zero values for the selected axis
- Linear movement measurement (by means of linear encoders)
- Rotary movement measurement (by means of rotary encoders)
- Memory for last position after switch off
- Entering shrinkage rate
- Setting 999 datum systems in SMD mode
- Movement direction indication
- Machining modes:
  - holes drilling along circle
  - holes drilling along oblique line
- Error correction: linear compensation
- Inside calculator
- Serial interface RS232

## MECHANICAL DATA

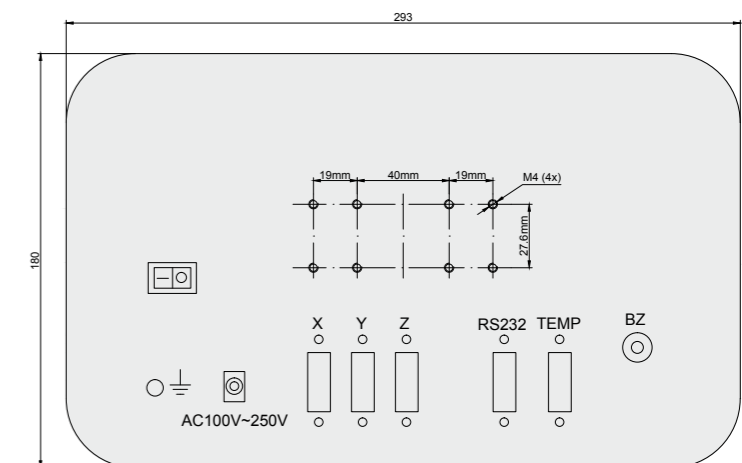

Connected only through 15-pins flat connector D15.

## ORDER FORM

CS	-	X1	-	X2
Digital readout device (X1):	Number of axis (X2):			
5500 - two or three axis	2 - two axis		3 - three axis	
ORDER EXAMPLE: 1) CS-5500-2				

## COMPATIBLE WITH:



A24HME1, A28, A36, A42M, A75M, A58M, A58B, A58C, A58C2, A58C3, A58D, AP58, A58HE, A58HE1, A58HME, A102H, A90H, A110, A110H, A170, A170H, A200H, L18, L18B, L18T, L23, L35, L35T, L37, L50, MT.

# ENCODER CONNECTORS

## ENCODER ELECTRICAL CONNECTION

FOR ~ 11  $\mu$ A

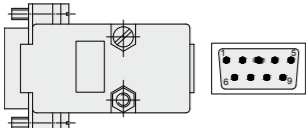
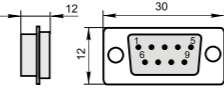

### 9-PINS FLAT CONNECTOR D9, MALE

FOR CABLE  FOR HOUSING  

8	4	7	3	6	2	5	9	1
I <sub>1</sub> +	I <sub>1</sub> -	I <sub>2</sub> +	I <sub>2</sub> -	I <sub>0</sub> +	I <sub>0</sub> -	+5V	0V	Shield
Green	Yellow	Blue	Red	Grey	Pink	Brown	White	Shield

\*External shield is connected to connector housing.

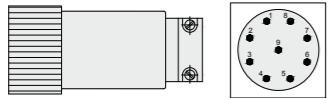
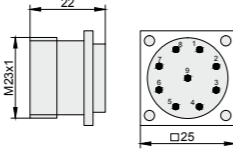

### 9-PINS ROUND CONNECTOR C9, MALE

FOR CABLE  FOR HOUSING  

1	2	5	6	7	8	3	4	9
I <sub>1</sub> +	I <sub>1</sub> -	I <sub>2</sub> +	I <sub>2</sub> -	I <sub>0</sub> +	I <sub>0</sub> -	+5V	0V	Shield
Green	Yellow	Blue	Red	Grey	Pink	Brown	White	Shield

\*External shield is connected to connector housing.

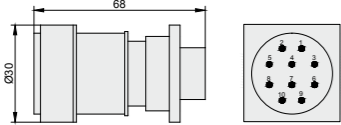
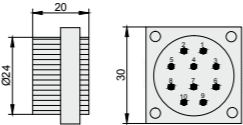
### 10-PINS ROUND CONNECTOR ONC, MALE

FOR CABLE  FOR HOUSING  



I <sub>1</sub> +	I <sub>1</sub> -	I <sub>2</sub> +	I <sub>2</sub> -	I <sub>0</sub> +	I <sub>0</sub> -	+5V	0V	Shield
2	5	8	7	6	10	4	9	1
Green	Yellow	Blue	Red	Grey	Pink	Brown	White	Shield

\*External shield is connected to connector housing.

## ENCODER ELECTRICAL CONNECTION

FOR ~ 1VPP; TTL; HTL

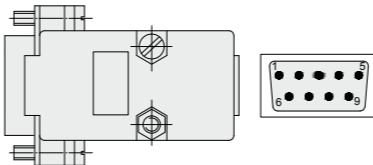
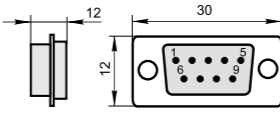

### 9-PINS FLAT CONNECTOR D9, MALE

FOR CABLE  FOR HOUSING  

Pin number	8	4	7	3	6	2	5	9	1
Color	Pink	Grey	White	Brown	Yellow	Green	Red	Blue	Shield
AV (~ 1V)	A+	A-	B+	B-	R+	R-	+5V	0V	Shield
TTL, U = +5V	U <sub>1</sub>	Ū <sub>1</sub>	U <sub>2</sub>	Ū <sub>2</sub>	U <sub>0</sub>	Ū <sub>0</sub>	+5V	0V	Shield
HTL, U = +(10...30)V	U <sub>1</sub>	Ū <sub>1</sub>	U <sub>2</sub>	Ū <sub>2</sub>	U <sub>0</sub>	Ū <sub>0</sub>	+ (10...30)V	0V	-

\*External shield is connected to connector housing.

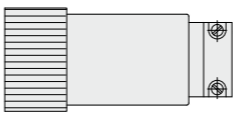
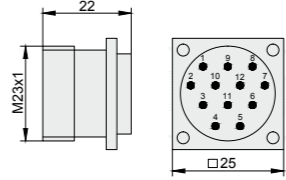
### 12-PINS ROUND CONNECTOR C12, MALE

FOR CABLE  FOR HOUSING  

Pin number	5	6	8	1	3	4	12	10	2	11
Color	Pink	Grey	White	Brown	Yellow	Green	Red	Blue	Black	Violet
AV (~ 1V)	A+	A-	B+	B-	R+	R-	+5V	0V	Sensor +5V	Sensor 0V
TTL, U = +5V	U <sub>1</sub>	Ū <sub>1</sub>	U <sub>2</sub>	Ū <sub>2</sub>	U <sub>0</sub>	Ū <sub>0</sub>	+5V	0V	Sensor +5V	Sensor 0V
HTL, U = +(10...30)V	U <sub>1</sub>	Ū <sub>1</sub>	U <sub>2</sub>	Ū <sub>2</sub>	U <sub>0</sub>	Ū <sub>0</sub>	+ (10...30)V	0V	Sensor + (10...30)V	Sensor 0V

\*External shield is connected to connector housing.

### 12-PINS ROUND CONNECTOR C12T, MALE

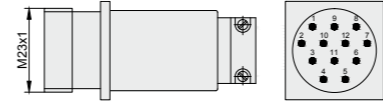
FOR CABLE  

Pin number	5	6	8	1	3	4	12	10	2	11
Color	Pink	Grey	White	Brown	Yellow	Green	Red	Blue	Black	Violet
AV (~ 1V)	A+	A-	B+	B-	R+	R-	+5V	0V	Sensor +5V	Sensor 0V
TTL U = +5V	U <sub>1+</sub>	U <sub>1-</sub>	U <sub>2+</sub>	U <sub>2-</sub>	U <sub>0+</sub>	U <sub>0-</sub>	+5V	0V	Sensor +5V	Sensor 0V
HTL U = +(10...30)V	U <sub>1+</sub>	U <sub>1-</sub>	U <sub>2+</sub>	U <sub>2-</sub>	U <sub>0+</sub>	U <sub>0-</sub>	+10...30V	0V	Sensor + (10...30)V	Sensor 0V

\*External shield is connected to connector housing.

# ENCODER ELECTRICAL CONNECTION

FOR ~ 1VPP; TTL; HTL

## 12-PINS ROUND CONNECTOR B12, MALE

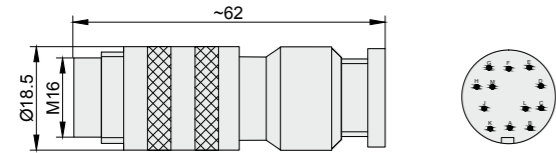

Pin number	C	D	E	L	G	H	K	B	A
Color	Pink	Grey	White	Brown	Yellow	Green	Red	Blue	shield
AV (~ 1V)	A+	A-	B+	B-	R+	R-	+5V	0V	shield
TTL, U = +5V	U1	Ū1	U2	Ū2	U0	Ū0	+5V	0V	shield
HTL, U = +(10...30)V	U1	Ū1	U2	Ū2	U0	Ū0	+(10...30)V	0V	shield

\*External shield is connected to connector housing.

## 15-PINS FLAT CONNECTOR D15, MALE

FOR CABLE

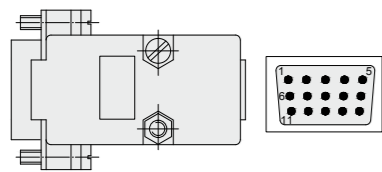

FOR HOUSING

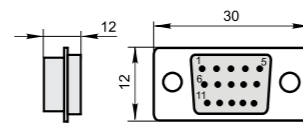

Pin number	3	13	4	14	5	15	1	2	6
Color	Pink	Grey	White	Brown	Yellow	Green	Red	Blue	Shield
TTL, U = +5V	U1	Ū1	U2	Ū2	U0	Ū0	+5V	0V	Shield

\*External shield is connected to connector housing.

## 15-PINS FLAT CONNECTOR D15T, FEMALE

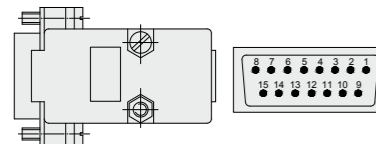

Pin number	3	4	6	7	10	12	1	2	9	11	5/8/13/14/15	*
Color	Pink	Grey	White	Brown	Yellow	Green	Red	Blue	Black	Violet	-	Shield
1Vpp, U = +5V	A+	A-	B+	B-	R+	R-	+5V	0V	Sensor +5V	Sensor 0V	No connected	Shield
TTL, U = +5V	U <sub>1+</sub>	U <sub>1-</sub>	U <sub>2+</sub>	U <sub>2-</sub>	U <sub>0+</sub>	U <sub>0-</sub>	+5V	0V	Sensor +5V	Sensor 0V	No connected	Shield

\* External shield is connected to connector housing.

## 10-PINS ROUND CONNECTOR RS10, MALE

FOR CABLE

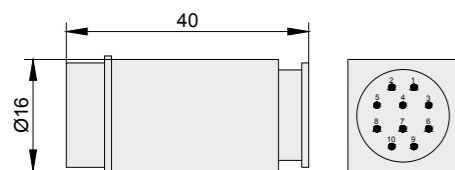

FOR HOUSING

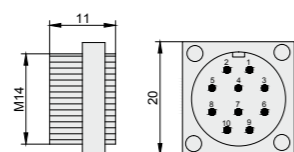

Pin number	5	8	3	6	10	1	2	9	4
Color	Pink	Grey	White	Brown	Yellow	Green	Red	Blue	Shield*
TTL, U = +5V	U1	Ū1	U2	Ū2	U0	Ū0	+5V	0V	Shield

\*External shield is connected to connector housing.

\*\*For voltage supply +(10...30)V pin 7 is used.

## 10-PINS ROUND CONNECTOR ONC, MALE

FOR CABLE

FOR HOUSING

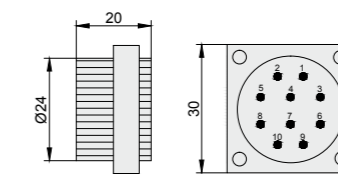
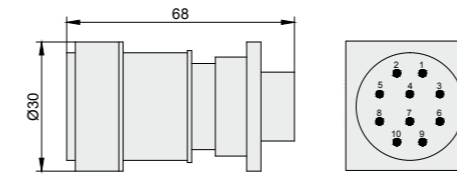

\*External shield is connected to connector housing.

U = +5V±5%

Pin number	1	2	3	4	10	9	5	6	7
Color	Pink	Grey	White	Brown	Yellow	Green	Red	Blue	Shield
TTL, U = +5V	U1	Ū1	U2	Ū2	U0	Ū0	+5V	0V	Shield

\*External shield is connected to connector housing.

\*\*For encoder A58B voltage supply +5V is on pin 8.

U = +5 and +15V

Pin number	1	2	3	4	10	9	8	5	6	7
TTL, U = 5/15V	U1	Ū1	U2	Ū2	U0	Ū0	+5V	+15V	0V	Shield

## CABLE LENGTHS

Maximal encoder (linear of rotary) cable length depending on output signal type is:

- sine-wave current signal A (~ 11 µA) – 5 m;
- sine-wave voltage signal AV (~ 1V) – 25 m;
- square-wave signal F (TTL) – 25 m;
- square-wave signal F (HTL) – 25 m.

The encoders can be equipped with additional prolonging cable (diameter 7 mm) with different cable connectors ONC, RS10, D9, C9, C12, B12 depending on customer requirements. This cable has an additional sensor circuits U and 0V.

Linear encoder cable can be protected by metal hose with additional plastic cover (IP64) type SYLVIN. Metal hose has diameter of 10 mm.







Product specifications are subject to change without prior notice.  
The product images shown are for illustration purposes only and may  
not be an exact representation of the product.



Zirmunu str. 139, LT-09120 Vilnius

[sales@precizika.com](mailto:sales@precizika.com)

+370 (5) 236 3600

[www.precizika.com](http://www.precizika.com)